

Alma Mater Studiorum Università di Bologna
Archivio istituzionale della ricerca

Critical comparative review of international standards on wireless charging for light-duty electric vehicles

This is the final peer-reviewed author's accepted manuscript (postprint) of the following publication:

Published Version:

Cirimele V., Freschi F., Zhao L. (2024). Critical comparative review of international standards on wireless charging for light-duty electric vehicles. IEEE TRANSACTIONS ON INDUSTRY APPLICATIONS, 60(5), 1-10 [10.1109/TIA.2024.3408107].

Availability:

This version is available at: <https://hdl.handle.net/11585/985457> since: 2024-09-18

Published:

DOI: <http://doi.org/10.1109/TIA.2024.3408107>

Terms of use:

Some rights reserved. The terms and conditions for the reuse of this version of the manuscript are specified in the publishing policy. For all terms of use and more information see the publisher's website.

This item was downloaded from IRIS Università di Bologna (<https://cris.unibo.it/>).
When citing, please refer to the published version.

(Article begins on next page)

Critical comparative review of international standards on wireless charging for light-duty electric vehicles

Vincenzo Cirimele*, *Senior Member, IEEE*, Fabio Freschi[†], *Senior Member, IEEE*, Lei Zhao[‡], *Member, IEEE*

*Dept. of Electrical, Electronics and Information Engineering, University of Bologna, Italy

[†]Department of Energy “G. Ferraris”, Politecnico di Torino, Turin, Italy

[‡]College of Automation, Chongqing University, Chongqing, China

Abstract—This paper presents an overview of the most important international standards published in the last years to regulate inductive-type wireless charging systems for electric vehicles. The main contents related to electrical power components are presented in comparative form and some of the critical points not yet resolved are highlighted.

Index Terms—Electric vehicles, inductive charging, wireless power transfer, standardization, batteries

I. INTRODUCTION

The advent of inductive wireless charging technology for electric vehicles, commonly referred to as wireless power transfer (WPT), has rendered it a valuable option for recharging vehicle batteries. There are numerous advantages to wireless charging. Firstly, it has a minimal aesthetic impact, particularly when charging stations must be installed in historical sites. Secondly, the charging process is straightforward and requires only the correct parking of the vehicle. This is of particular interest to individuals with mobility disabilities. Thirdly, the absence of a visible charging structure makes such systems less susceptible to vandalism [1].

In the first decade of the 2000s, renewed attention was given to this technology and its application in high-power systems. This was primarily due to the work of researchers at the University of Auckland who demonstrated the applicability of this technology in industrial systems over distances of the order of a few centimeters by taking advantage of the ever-increasing capabilities of modern static conversion devices to switch at high frequencies and at relatively high voltage and current levels [3]–[5]. This initial research concentrated on rail and autonomous guided vehicles, where both the air gap and the lateral position of the vehicle are fixed. The work of KAIST, the Korea Advanced Institute of Technology, was a significant factor in the global interest in wireless power technology. This was evidenced by the development of various applications referred to under the acronym OLEV (OnLine Electric Vehicle) [6], [7].

To date, several prototypes have been developed around the world for both static (i.e., with a stationary vehicle during the charging phase) and dynamic systems (i.e., the power transfer occurs during the vehicle movement) [8]–[11]. Some

automobile manufacturers have recently begun offering wireless power transfer (WPT) charging systems for their electric models [12]–[14]. The development of the market necessitates the availability of international standards that could define the fundamental characteristics, constraints, and validation criteria of WPT for automotive applications.

Although major regulatory bodies have already produced standards, the harmonization of different standards is still in its early stages. This has frequently resulted in a general lack of uniformity and, at times, conflicting content. These discrepancies are still apparent in certain aspects of the current standards, which often presents practical challenges for certification bodies tasked with ensuring compliance with the international regulatory framework.

This paper aims to provide an updated overview of the current international regulatory framework highlighting similarities, differences, and conflicting areas. The objective is to provide support for designers, researchers, and stakeholders dealing with the wireless charging of light-duty electric vehicles, assisting them in understanding the technical issues underlying the requirements and recommendations of the standards [2]. This work complements, complete, and updates previous efforts to organize all contributions to WPT standardization for automotive applications [43], [44]. In order to facilitate comprehension of the numerous and complex pages of the documents, specific references to sections of the different standards are provided. The standards analyzed are those issued by the Society of Automotive Engineers (SAE), the International Electrotechnical Commission (IEC), and the International Organization for Standardization (ISO). In light of the significant technological advancements, substantial financial investments, and expansive market penetration of wireless charging systems, the overview also includes an examination of the standardization efforts in China, specifically the national standardization body, the Guó Biāo (GB).

The examined standards cover a range of different aspects of the technology, including general definitions, security aspects, the implementation of equipment for testing, and compliance verification in terms of power quality and communication integrity. This paper will specifically address the aspects related to general definitions and the main operational parameters of the components dedicated to the management of power. The analysis does not include the aspects of electromagnetic

compatibility and communications management.

II. OVERVIEW OF THE STANDARDS

A. International Electrotechnical Commission - IEC

The IEC was the first institution to publish a standard on static inductive charging for light electric vehicles. The first document was Part 1 of the standard *IEC 61980 - IEC Electric vehicle wireless power transfer (WPT) systems* released in July 2015. The complete standard body had to wait for the release of Parts 2 and 3 in June 2019. All three parts were updated and changes in 2020 and 2021 and Part 2 alone was updated again in May 2023. The standard currently consists of three parts:

- IEC 61980-1:2020 Part 1: General requirements [15]
- IEC TS 61980-2:2023 Part 2: Specific requirements for communication between electric road vehicle (EV) and infrastructure [16]
- IEC 61980-3:2022 Part 3: Specific requirements for magnetic field wireless power transfer systems [17].

B. Society of Automotive Engineers - SAE

Although regarded as a reference in the scientific literature, the SAE standard is the second in the standardization timeline. In fact, the initial draft of the SAE J2954 standard was released in May 2016, while the first stable version was made available in November 2017. The standard underwent several updates in 2019, and 2020 and the latest available version was published in August 2022. The standard is comprised of a single document entitled *SAE J2954 Wireless Power Transfer for Light-Duty Plug-In/Electric Vehicles and Alignment Methodology* [18].

C. International Organization for Standardization - ISO

ISO publications have followed those of the IEC and SAE. The first version of the ISO 19363 standard was issued in 2017. The current version of the standard was issued in 2021 and is entitled *EN ISO 19363 Electrically propelled road vehicles - Magnetic field wireless power transfer - Safety and interoperability requirements* [19].

D. Guó Biāo - GB

In 2020, China initiated the development of its own regulatory reference on wireless charging, the *GB/T 38775 Electric vehicle wireless power transfer standard*. The standard is comprised of seven distinct documents, each of which addresses a distinct aspect of the charging system:

- GB/T 38775.1-2020 Part 1: General requirements [20]
- GB/T 38775.2-2020 Part 2: Communication protocols between on-board charger and wireless power transfer device [21]
- GB/T 38775.3-2020 Part 3: Specific requirements [22]
- GB/T 38775.4-2020 Part 4: Limits and test methods of electromagnetic environment [23]
- GB/T 38775.5-2021 Part 5: Electromagnetic compatibility requirements and test methods [24]

- GB/T 38775.6-2021 Part 6: Interoperability requirements and testing-Ground side [25]
- GB/T 38775.7-2021 Part 7: Interoperability requirements and testing-Vehicle side [26]
- GB/T 38775.8-2023 Part 8: Special requirements for commercial vehicle applications [27].

In the Chinese language, the acronym GB/T stands for “recommended” (tuī jiàn), “national standard” (guó jiā biāo zhǔn). This designation implies that the standard is not mandatory but rather voluntarily adopted. Nevertheless, the standards referred to as T already serve as a widely accepted technical foundation for economic operators engaged in the relevant production field. In the sections of this paper that address the matters under consideration, the content of the GB standard is largely based on the IEC standard, with some exceptions highlighted in the following sections.

All standards mentioned thus far address only stationary electric vehicle systems with a maximum system supply voltage in the low voltage range (i.e., 1000 V rms in AC or 1500 V in DC). All standards are applicable to light electric vehicles, with the exception of the GB standard which refers to general electric vehicles. This broader applicability is also evidenced by the power levels considered, as highlighted in Section IV

In December 2022, the SAE published the Information Report J2954/2 - *Wireless Power Transfer for Heavy-Duty Electric Vehicles* with the intention of extending the applicability of the standardization to power ratings above 22 kW. With this document, the SAE is the first standard-setting organization to consider dynamic charging [28]. According to the SAE website, once they reach their final form, SAE J2954/2 will be limited to static charging of heavy-duty vehicles, whereas SAE RP J2954/3 [29] will be dedicated to dynamic wireless power transfer (denoted by D-WPT) of both light and heavy-duty vehicles. Heavy-duty vehicles are also referenced in the IEC standard, but with only minimal information and in a purely informative annex [17, Annex CC]. In contrast, there is no reference to dynamic systems.

III. GENERAL REQUIREMENTS

The standards for WPT were designed to maintain consistency with the standards that had already been established for plug-in type charging systems. As will become evident in the subsequent sections, this continuity is primarily based on the power levels that have been utilized for both charging stations and in-vehicle converters, which are referred to as AC Level 1 and Level 2 in the SAE J1772 Standard [30], [31].

A. Definitions

Fig. 1 describes the structure of a WPT system (also designated as magnetic field WPT, MF-WPT, by ISO [19, Sec. 1], GB [20, Sec. 4], and part 3 of IEC [17, Sec. 1]). The power transfer is based on the magnetic coupling of two coils, the transmitter coil placed in or on the ground and the receiver coil mounted on the vehicle. The transmitter coil is powered by a DC/AC converter that may interface with the power

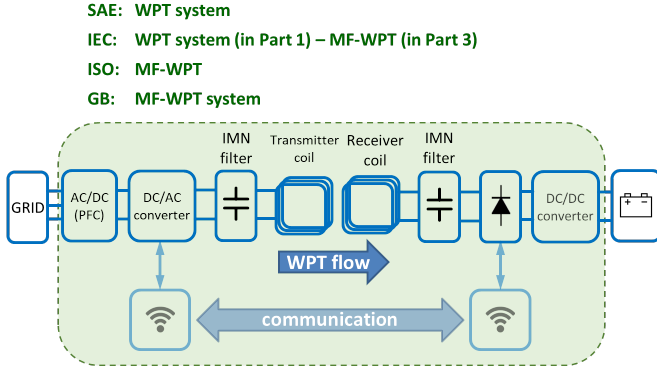

Fig. 1: WPT system general description. The shaded area includes the equipment that belongs to the WPT system.

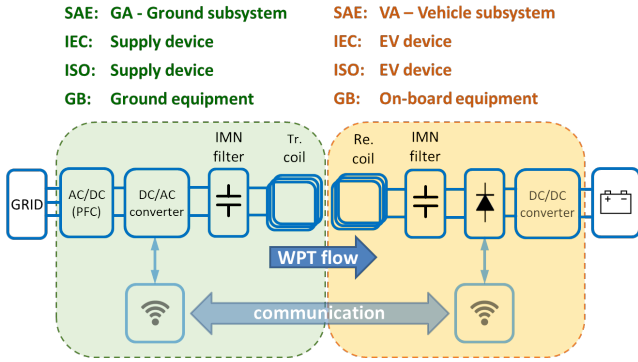

Fig. 2: Main WPT system subsets.

grid via a power factor correction (PFC) converter. In the vehicle, the receiver coil is connected to one or more AC/DC converters that also serve as an interface to the battery. Both coils are connected to reactive elements, mainly capacitors, referred to as impedance matching networks (IMNs). These elements are necessary to tune the impedance matching toward the converters, maximize the transferred power, and allow the converters to operate in soft-switching conditions [33], [34].

The set of such components and their subsets are categorized differently in the different standards as can be seen in the different subsets sketched in Figs. 2–3

In the case of the SAE standard, all off-board elements are referred to as ground assembly (GA) while in-vehicle elements are referred to as vehicle assembly (VA) [18, Sec. 1.1] (see Fig. 2). Differently, the IEC and ISO standards have adopted the subdivision into supply (side) and EV (side) [15, Sec. 7.1], [16, Sec. 5.1], [17, Sec. 7.101], and [19, Sec. 4]. The GB standard refers to ground (side) and on-board (side) [20, Sec. 5.2], [25, Sec. 5.1], and [26, Sec. 5.1].

Regarding coils alone, the IEC, ISO, and GB standards propose a nomenclature reminiscent of transformers, indicating the transmitter as primary and the receiver as secondary.

At present, all standards address unidirectional charge only. This is explicitly stated in the scope section of SAE and IEC standards, in which the possibility of bidirectional transfer is indicated as a possible future development. Neither the ISO nor the GB standards explicitly refer to bidirectional power flow, nor do they provide any indication of it within the

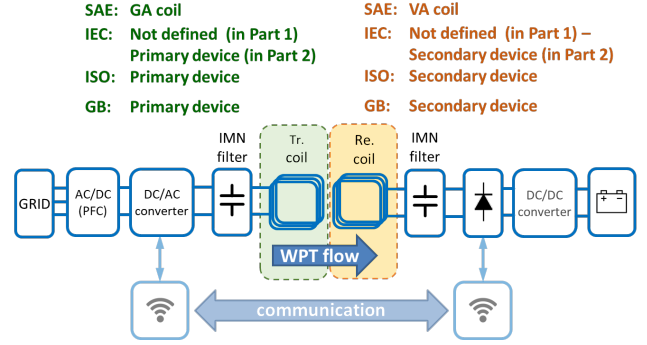

Fig. 3: WPT system subsets related to the only coils.

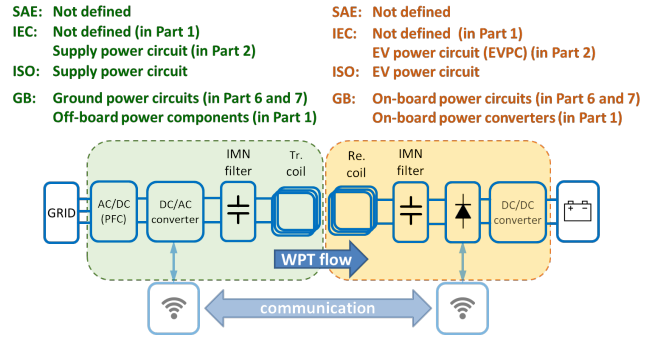

Fig. 4: Main WPT system subsets related to the only components managing the power flow.

scope. Nevertheless, in the diagrams used for the definitions, power flow is indicated with a double arrow, thereby explicitly indicating the potential for reversible power exchange between the vehicle and the ground side.

The nomenclature related to the different subsystems responsible for power management and power conversion stages is reported in Fig. 4 and Fig. 5 respectively.

Unless otherwise stated, in this paper the SAE terminology will be used to avoid any potential confusion.

IV. POWER CLASSIFICATION

The main classification of WPT systems is determined by taking into consideration the level of power required at

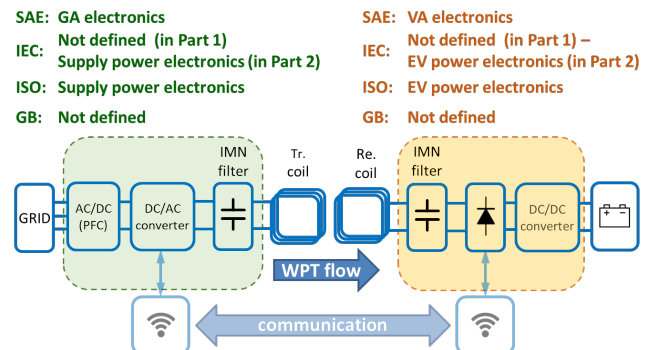

Fig. 5: Main WPT system subsets related to the power conversion stages.

the point of connection to the grid. In this case, the ISO standard does not propose its own classification but instead refers directly to the IEC standard. Based on these power levels, the IEC standard defines the *transfer power classes* shortly indicated as MF-WPT classes [17, Sec. 6.3] similarly to the GB standard that uses the wording *input power levels* [20, Sec. 6.2]. In contrast, the SAE standard defines the *WPT power classes* [18, Sec. 5.1]. In all documents, these classes are denoted by the abbreviation WPT followed by an increasing number. A summary of this classification is provided in Table I.

A comparison of the values in the table reveals three significant discrepancies in the standards. The first discrepancy pertains to the definition of power. While the SAE standard references apparent power, measured in kilovoltamperes, the IEC and GB standards utilize real power, measured in kilowatts. In the authors' opinion, the IEC and GB standards provide a more straightforward indication, as the use of real power allows for a direct correlation between the rated power value of the WPT system and the power transferred to the battery. Further discussion on efficiency aspects can be found in Section VII). However, it is fair to note that, in practical applications, and particularly in the presence of a PFC (which is only mentioned in the SAE standard as an element of the GA), a correct design of the system allows for the reactive power to be considered negligible in comparison to the real power [35].

The second, and more substantial, difference concerns the bounds of the power ranges under consideration. For all standards, the upper bound of each class is defined as the maximum power that can be absorbed from the grid. This level represents the lower bound for the subsequent class. In contrast, in the SAE standard, the lower limit of each class is always zero. This can, in some cases, result in ambiguity regarding the classification, as the rated power can be selected at any value within the range. Furthermore, the ranges that define the WPT classes exhibit extensive overlap.

The most apparent discrepancy is observed in the delineation of higher power classes. Indeed, the definitions are very different among the standards. The congruence is disrupted at class WPT4 (for powers above 11.1 kW/kVA): in both the SAE and IEC standards, classes WPT4 and WPT5 are listed, but specifications are deferred to future versions. In addition, the WPT5 class has a 60 kVA upper bound for the SAE standard, while it is unbounded for the IEC standard. The GB standard employs a distinct classification for high-power classes. In fact, the upper bound of WPT5 has a power rating of 33 kW, but two additional classes are introduced, namely WPT6 and WPT7, for powers in the range 33 kW – 66 kW and above 66 kW, respectively. No further specifications are provided, with the exception of the recommendation that power classes above WPT3 must not be supplied with single-phase circuits.

V. Z-CLASS CLASSIFICATION

The definitions concerning the mutual position of coils are not harmonized among the different standards, and they also

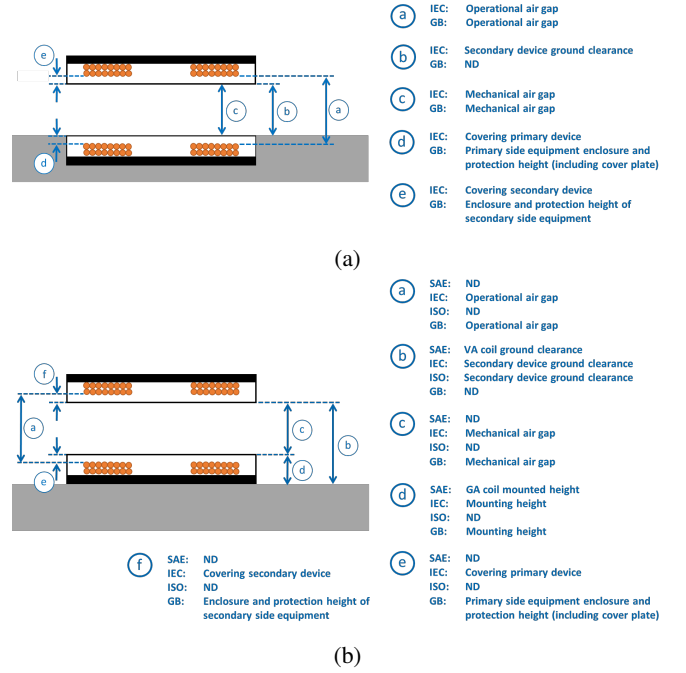

Fig. 6: Definitions of the different mechanical distances for coil assemblies: (a) flush ground mounting and (b) above ground mounting.

use a different number of geometrical parameters, graphically reported in Fig. 6 [18, Sec. 5.2 and Sec. 7.2], [17, Sec. 3.121 and Sec. 3.122], [20, Sec. 5.4.2 and Sec. 5.4.3].

In general, the GA and VA coils comprise a coil that can be wound on one or more layers, one layer of ferromagnetic material (typically ferrite), and one layer of conductive material (typically aluminum or steel) which act as electromagnetic shield. The assembly is enclosed in an insulating casing. The GA coil assembly may be installed on the ground or buried in the ground. The first case is referred to as *above ground* mounting for SAE [18, Sec. 5.3] and GB standards [20, Sec. 5.4.3] and *surface mounted* assembly for the IEC standard [17, Sec. 3.122] (see Fig. 6b). In contrast, the second case is referred to as *underground* in the GB standard [20, Sec. 5.4.2] and as *flush mounted* in the IEC standard [17, Sec. 3.121] (see Fig. 6a). The SAE standard distinguishes between *flush ground* mounting, when the outer casing is surfacing the ground, and *buried mounting* when the outer casing is buried at a distance below the ground surface [18, Sec. 5.3]. However, the SAE explicitly states that only above-ground installations are covered by the current version of the standard. The ISO standard does not explicitly mention the various mounting possibilities.

All the distances defined in Fig. 6 refer to the z -axis of the reference system shown in Fig. 7, common to all three standards.

In the previous versions, there was a discrepancy in the reference system among the standards. The IEC standard adopted a left-handed coordinate system in which the x -axis was oriented according to the direction of vehicle movement and the y -axis was oriented leftward. From 2020 onward, all

TABLE I: WPT power classes for SAE, IEC (same of ISO), and GB standards. Ranges are in kilowatt*. The upper bound of the range must be considered as included in the range.

	WPT1	WPT2	WPT3	WPT4	WPT5	WPT6	WPT7
SAE*	0 – 3.7	0 – 7.7	0 – 11	0 – 22**	0 – 60**	-	-
IEC/ISO	0 – 3.7	3.7 – 7.7	7.7 – 11.1	11.1 – 22***	> 22***	-	-
GB	0 – 3.7	3.7 – 7.7	7.7 – 11.1	11.1 – 22***	22 – 33	33 – 66	> 66

* SAE classification is in kVA

** WPT4 and WPT5 indicated as “under consideration for the next version of the standard”.

*** Input power higher than 11.1 kW are indicated as “under consideration for further editions”.

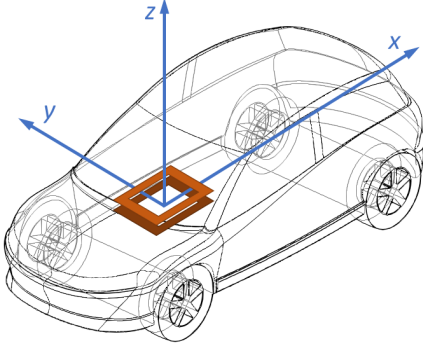

Fig. 7: Reference three-dimensional coordinate system adopted by SAE, IEC, and ISO standards from 2020.

four standards were harmonized by adopting the coordinate reference system defined by the ISO 4130 standard [36]. This system is based on a right-handed coordinate system in which the x axis is oriented in the direction opposite to the direction of vehicle movement and z -axis is oriented against the gravity. The origin $(x, y) = (0, 0)$ of the coordinate system is set in the geometric center of the GA coil and the coordinate $z = 0$ coincides with the ground surface.

In order to specify the vertical distance over which the system can transfer power, SAE and IEC standards introduce the *Z-classes* [18, Sec. 5.2], [17, Sec. 6.101]. This distinction is referred to as *ground clearance classification* in the GB standard [22, Sec. 5.4] and [25], [26, Sec. 5.2.3], but again the same nomenclature is used. Z-classes make reference to the distance between the lowest part of the VA insulating casing and the ground (i.e. the quantity ⑥ in Fig. 6).

A Z-class designation may pertain to either the VA or to the GA. The rationale for this distinction lies in the fact that the manufacturer of the VA may differ from the manufacturer of the GA. Consequently, the two systems must be able to permit power transfer in a similar way to that observed in the charging of plug-in electric vehicles by means of a wired connection.

The SAE and GB standards both report this differentiation, while for the IEC standard, this classification applies to the GA ground subsystem, Fig. 2). It is however, worth noting that the SAE standard explicitly states that [18, Sec. 5.2.2]:

TABLE II: GA Z-classes for SAE and IEC standards.

Z-class	Range (mm)
Z1	100 – 150
Z2	100 – 210
Z3	100 – 250

TABLE III: VA Z-class for SAE J2954 standard (and ground clearance for the GB/T 38775).

Z-class	Range (mm)
Z1	100 – 150
Z2	140 – 210
Z3	170 – 250
Z4	> 250*

... a product VA does not need to be classified by Z-Class, but rather by the range of VA coil ground clearance over which it operates.

From this, it is possible to conclude that the only classification that is of practical relevance is that referring to the GA.

The ranges of the different GA Z-classes for SAE and IEC standards are presented in Table II, while the ranges of the VA Z-classes (and ground clearance classification of the GB standard) are summarized in Table III. The Z4 class is considered only by the GB standard for the sole purpose of categorization.

In accordance with the SAE and IEC standards, these values refer to a maximum GA height (i.e., the parameter ① in Fig. 6b) of 70 mm. In the GB standard, this specific information is not reported. Instead, a minimum value of the mechanical air gap (i.e., the parameter ③ in Fig. 6b) is given for different vehicle typologies: S, M, and L [22, Sec. 5.3] (see Table IV).

It can be observed that for all standards the same upper extremes are considered for the different ranges while there is differentiation for the lower extremes. In particular, the same lower value of 100 mm is proposed for all Z-classes from the latest versions of the SAE and IEC standards.

This concept is continued in Annex B of the SAE standard and in Section 7 (Interoperability) of the IEC standard in which all the electrical and mechanical specifications are provided

TABLE IV: Minimum mechanical air gap indicated in the GB/T 38775 standard.

Typology	Mechanical air gap (mm)
S	80 ± 30
M	130 ± 30
L	190 ± 40

for the realization of the so-called universal GA, namely a WPT3 Z3-class system capable of operating with a VA ground clearance over the entire range 100 mm – 250 mm.

Z-classes are not included in the ISO standard, which provides a single range indication of *secondary device ground clearance* ranging from 100 mm to 250 mm. The ISO standard notes that this classification is functional for systems that are intended for interoperability (which are categorized as Class A), but that it is not required for devices that are not intended for interoperability (namely Class B) that are tested with supplier-specified supply power circuits [19, Sec. 7.1].

VI. OPERATING FREQUENCY

The rated operating frequency is a parameter for which all standards have agreed from the earliest drafts. Nevertheless, the agreement on the operational frequency ranges was only reached in the most recent editions. The current consensus among the various standards is that the operating frequency falls within the range 79 kHz and 90 kHz. However, the latest version of the IEC standard reports a lower bound of 81.38 kHz specifying in a note that this value needs to be confirmed by the Radiocommunication sector of the “International Telecommunication Union” (ITU) [17, Sec. 7.108]. The same narrower range was also used by the ISO standard before the last version, when it was harmonized with the IEC standard.

The SAE and IEC standards indicate a specific nominal frequency of 85 kHz and the IEC standard additionally reports a tolerance of ± 50 Hz on that value. The IEC standard specifies that this tolerance should be observed in systems operating at a fixed frequency. In the case of variable-frequency operation, both the IEC and the SAE standards allow the possibility of varying the frequency within the range. However, the SAE standard recommends that the frequency remain fixed during the entire charging session, with a maximum variation of 50 Hz.

The GB standard does not directly report any frequency value; however it makes reference to other documents [22, Sec. 5.2]. In particular, it cites the “Interim Regulations on Radio Management of Wireless Charging (Power Transmission) Equipment” [37] of “Regulations of the People’s Republic of China on the Division of Radio Frequencies”. A note specifies that such guidance should also comply with the ITU. The GB standard does not define the frequency values for systems above WPT4. A note explicitly states that these values will be determined in subsequent editions of the standard. In contrast, for all other power classes, a nominal value and allowable range are provided. Document [37] indicates

that for wireless charging systems for electric vehicles with power ratings below 22 kW, the expected working frequency range is 79 kHz – 90 kHz with a nominal frequency of 85 kHz, as explicitly stated in all other standards. Furthermore, as indicated in [37], this frequency should remain constant throughout the charging process, with a variation limited to ± 50 Hz. The GB standard explicitly states that frequency tuning can be employed to correct the power variations due to misalignment or variation in the air gap. However, the conditions and modalities under which the frequency variation is permissible are not specified.

Among all standards, the SAE standard is the only one that allows for the possibility of deviating from the specified frequency range in cases where such variation is necessary to operate under optimal performance conditions. In such cases, the working frequency should be determined at the beginning of the charging session and the power employed should not exceed 25% of the lower between the GA input power rating and the VA output power [18, Sec. 6.4.2]. However, the SAE standard does not provide any details regarding the operating conditions that may require a change in frequency and how much that frequency may deviate from the reference range. Consequently, it is challenging to comprehend the operational constraints that emerge from this assertion.

The SAE and the ISO standards specify that the frequency is solely determined by the GA, yet it is imperative that there is an accord between the GA and VA operating frequency. The ISO standard specifies that an agreement must be reached prior to the start of charging following *negotiations* with the EV device.

In examining the operational frequency indications, it is worth noting that [37], in the latest version of 2023, considers operative frequency ranges for a very wide range of wireless charging applications. In the context of automotive applications, a frequency range of 19 kHz – 21 kHz is given for all charging systems with powers between 22 kW and 120 kW. This indication appears to be closely associated with the predominant technologies of static switches. In fact, while for power ratings below a few tens of kilowatts, the industrial world is moving toward silicon carbide devices, with switching frequencies in the order of one hundred kilohertz, for higher power ratings the most popular technology standard remains silicon IGBTs with typical switching frequencies in the order of ten of kilohertz [38], [39].

In conclusion, it appears that the information regarding the operating frequency and potential deviations from its rated value is not consistent across the various standards. It is therefore recommended that future revisions of the standards include more detailed information about potential deviations with respect to the operating frequency.

VII. EFFICIENCY

All standards agree on the definition of efficiency as the ratio between the power delivered to the battery (output from the EV power circuit, Fig. 4), and the power drawn from the grid (toward the supply power circuit, Fig. 4).

According to the IEC and ISO standards, the WPT system is required to achieve a minimum efficiency of 85% for all power

TABLE V: Allowed misalignment offsets along x and y axes for all analyzed standards.

Offset	Maximum value
Δx	± 75 mm
Δy	± 100 mm

classes (WPT1-WPT3) under ideal alignment conditions, and a minimum efficiency of 80% over the entire permissible range of misalignment [17, Sec. 7.104], [19, Sec. 7.5]. This range is defined by offsets along the x and y coordinates (Fig. 7) as shown in Table V.

The definition of power required to assess efficacy reveals notable divergences among the established standards. The IEC standard specifies that “*the measurement of the efficiency shall be done at rated input power*” [17, Sec. 7.104]. In contrast, the ISO standard refers, in a generic way, to the conditions of compliance with the efficiency requirements “*at power levels below the rated output power*” [19, Sec. 7.5].

Finally, the ISO standard states “*Typical local supply network connections should be considered*”. However, this statement appears to be of a very qualitative nature, and it is challenging to define the operating conditions that correspond to this statement, particularly in order to ensure the repeatability of the test conditions.

In terms of efficiency specifications, the SAE and GB standards appear to be the most consistent and structured. Furthermore, the specification indicate a minimum required efficiency of 85% under perfect alignment conditions and a minimum efficiency condition in the allowable misalignment range of 80% [18, Sec. 8.2.8], [25, Sec. 6.4.4], [26, Sec. 6.4.4].

Regarding the SAE standard, these indications refer specifically to instances where a generic VA product is tested with the GA test bench described in the Appendix B of the standard. Under conditions of perfect alignment, it is necessary to verify compliance with the minimum efficiency limits by placing the VA at the center position of the relevant Z range, at rated power and when the GA input voltage and VA output voltage are at their rated values. Under mismatch conditions, the reference power is assumed to be equal to the lower of the rated maximum input power to the GA or the rated output power of the VA. Conversely, a set of threshold values for each WPT class is provided in the case where a GA system is subject to testing. The minimum efficiency values under all alignment conditions for public installation and use (Class I GA) are presented in Table VI. In this context, it is necessary for a GA to be capable of operating with a wide range of interoperability between different power levels and air gaps that may be presented by different VA.

The GB standard also provides two unambiguous minimum efficiency levels, targeted for public use devices (referred to as Class A), of 85% and 80% percent under conditions of alignment and maximum misalignment, respectively. These levels align with those set forth in the IEC and ISO standards. The GB standard then indicates that the efficiency test should be performed with power received at the battery within the power range provided for the respective WPT class of the

TABLE VI: Minimum system efficiency requirements for SAE referred to publicly usable WPT systems (referred to as Class I GA)

WPT class	Centered position	Misalignment
WPT1	80%	75%
WPT2	82%	77%
WPT3	85%	80%

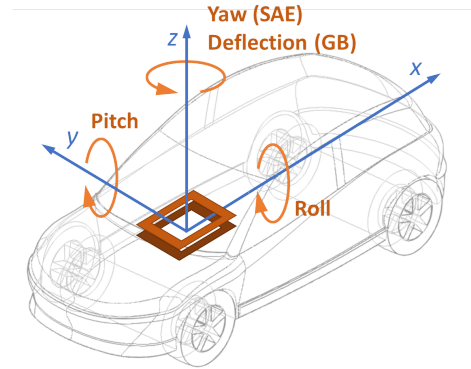

Fig. 8: Reference three-dimensional angular offsets indicated by the SAE and the angular deflection indicated by the GB standard.

device to be characterized. In the case of the characterization of GA and VA belonging to two different classes, the two devices are tested together in the power range associated with the lower class. In both cases, the lower bound of the WPT class is reduced according to the minimum efficiency. For example, the test of a WPT2 system is carried out with an output power between 2.96 kW (i.e., 80% of 3.7 kW) and 7.7 kW. It should be pointed out that the GB standard requires that power and efficiency are measured also with a deflection (yaw) of 10° (see Fig. 8).

The angular misalignment is also defined in the SAE standard, providing the maximum values tolerated [18, Sec. 8.2.3]. These values are graphically defined in Fig. 8 and reported in Table VII. It should be noted, however, that these parameters are not related in any way to evaluations of transmitted power and efficiency differently from the translation offsets.

Among the various standards, the GB is the one that currently defines the test procedure for characterization in terms of efficiency in greater detail, taking into account different supply conditions and providing precise clearance values. In the IEC standard, the sections *System efficiency test* and *Power transfer performance test* are listed as “*under consideration*”.

TABLE VII: Maximum angular offsets by SAE standard.

Rotation	Maximum value
Roll	2°
Pitch	2°
Yaw	3°

VIII. SAFETY

With regard to safety issues, the standards in question exhibit a certain degree of variation in terms of the level of detail they contain. The reasons for these discrepancies are primarily attributable to historical factors and the technical background of the standardization bodies. It is reasonable to expect that the IEC standard will be more detailed than the others. The ISO standard is the next more detailed, while the SAE standard reports only a reduced set of requirements. In general, the IEC prescribes protection against direct and indirect contacts [15, Sec. 10] in accordance with the usual safety measures for low-voltage electrical installations described in [40]. In particular fault protection is considered to be ensured through the implementation of one or more of the following measures:

- automatic disconnection of supply;
- double insulation;
- electrical separation;
- extra low voltage

A suitable residual current device is necessary for the protection of permanently connected supply devices. In order to ensure protection against electric shock, the ISO standard [19, Sec. 10.2] requires compliance with [41]. Both standards provide recommendations regarding the coordination of insulation. In particular, within the vehicle the insulation must be designed to withstand the maximum internal operational and overvoltages.

It is imperative that accessible parts of the supply device not exceed certain temperatures to prevent the occurrence of skin burns in all operational scenarios. It is important to note that the magnetic field used in WPT has the potential to cause the heating of metallic objects in proximity to the GA. Consequently, it is necessary to implement protective measures in order to mitigate the risk of burns, to limit the probability of ignition of flammable material, and to avoid damage to the GA coil package surface.

All standards delineate specific requirements regarding exposure to electromagnetic fields. In fact, due to the high power and high current of these devices, the electromagnetic fields can generate adverse effects due to heating or nerve stimulation. The SAE, ISO, and GB standards make reference to the exposure limits for specific frequencies, as outlined in the ICNIRP Guidelines [45]. The SAE standard refers to these measures as living object protection [18, Sec. 8.7.3.2]. In the frequency range of 79 kHz–90 kHz the field levels prescribed by the ICNIRP Guidelines are 27 μT for the magnetic field and 83 V/m for the electric field. In order to assess the protection of people against electromagnetic effects, three protection areas (referred to as “regions” in the SAE standard [18, Sec. 10.1]) are identified:

- protection area 1: area underneath the vehicle. The GB standard distinguishes between the space formed by the outline of the GA and VA and the rest of the region underneath the vehicle [20, Sec. 10.6];
- protection area 2: area surrounding the vehicle;
- protection area 3: vehicle interior.

All standards agree that in areas 2 and 3, the electric and magnetic fields must comply with the limits provided by the

ICNIRP Guidelines. Area 1 is the region where the power transfer occurs. Consequently, it is challenging to comply with the ICNIRP exposure limits in this area. For this reason, additional measures are suggested:

- measures to prevent people from entering the area
- measures to detect the presence of people (living object detection and protection) and shutdown (or reduction according to IEC) of the power transfer

All standards consider the possibility of protection of individuals with cardiac implantable electronic devices (CIED) also known as active implantable medical devices (AIMD), in accordance with the ISO standard. In areas 2 and 3, the limits are reduced to 15 μT in order to ensure that the induced voltage in the pacemaker leads is less than 180.31 mV at 85 kHz in accordance with [42]. In this context, the GB standard is less restrictive, with a field limit of 21.2 μT [23, Sec. 5.1.2].

IX. CONCLUSIONS

This study examined the content of the most recent versions of the SAE, IEC ISO, and GB standards pertaining to the power components of inductive wireless transfer systems for light electric vehicles.

It was demonstrated that, in the progression of the various editions of these documents, there is a tendency toward a general uniformity of content. This overall uniformity is also evident in the nascent GB standard. Nevertheless, it was observed that there persists considerable divergence of opinion on numerous points, with the guidance provided on occasion being open to different interpretations. Such discrepancies can be observed in the initial sections that delineate the definitions of the various components of the system. The nomenclature appears to be non-uniform, and the WPT system is divided into a different number of subsystems in the different standards. This nomenclature issue is also evident in the definitions of the geometrical parameters. In this instance, the IEC appears to be more comprehensive, defining twice as many parameters as the SAE. Moreover, the nomenclature differs in several instances. It is important to note, however, that not all parameters are actually used for operational definitions.

One of the points on which there is general agreement is the nominal operating frequency and the permissible range of variation of the latter. It is important to note, however, that the IEC standard indicates the necessity for confirmation with respect to the lower bound of this range. This necessity is not explicitly stated in the other standards. Regarding the maximum power levels that define the WPT classes, there is general agreement, although there is a difference in the units of measurement adopted. Nevertheless, there is still no consensus regarding the lower limits of the power ranges. The GB standard is the only one that considers and classifies power levels greater than 22 kW but, as made explicit in the paper, many of the parameters related to such power remain under definition. It is also noteworthy that SAE is developing a dedicated standard that will form part of the J2954 standard series.

With regard to the minimum efficiency requirements under different operating conditions, a general uniformity appears to

be evident. It is important to note that, with regard to the IEC and ISO standards in particular, the procedures and conditions for efficiency testing have not yet been fully established.

REFERENCES

- [1] Cirimele, V., Freschi, F., Mitolo, M. "I Charge, Therefore I Drive: Current State of Electric Vehicle Charging Systems", *IEEE Power and Energy Magazine*, vol. 21, no. 6, pp. 91-97, Nov.-Dec. 2023, doi: 10.1109/MPE.2023.3308227.
- [2] Cirimele, V., Freschi, F. "Critical comparative review of international standards on wireless charging for light-duty electric vehicles", *IEEE IAS 2023 Annual Meeting*, 2023, pp. 1-6, doi: 10.1109/IAS54024.2023.10406548.
- [3] Boys, J. T., Covic, G. A., Green, A. W. "Stability and control of inductively coupled power transfer systems". *IEE Proceedings-Electric Power Applications*, vol. 147, n. 1, pp. 37–43, Jan 2000, doi: 10.1049/ip-epa:20000017.
- [4] Kacprzak, D., Covic, G. A., Boys, J. T. "An improved magnetic design for inductively coupled power transfer system pickups". *2005 International Power Engineering Conference*, 29 Nov. – 2 Dec. 2005, Singapore, doi: 10.1109/IPEC.2005.207077.
- [5] Elliott, G.A.J., Covic, G. A., Kacprzak, D., Boys, J. T., "A new concept: Asymmetrical pick-ups for inductively coupled power transfer monorail systems". *IEEE Transactions on Magnetics*, vol. 42, n. 10, 2006, pp. 3389–3391, doi: 10.1109/TMAG.2006.879619.
- [6] Huh, J., Lee, S. W., Lee, W. Y., Cho, G. H., Rim, C. T. (2011). "Narrow-width inductive power transfer system for online electrical vehicles". *IEEE Transactions on Power Electronics*, vol. 26, n. 12, 2011, pp. 3666–3679, doi: 10.1109/TPEL.2011.2160972.
- [7] Choi, S. Y., Gu, B. W., Jeong, S. Y., Rim, C. T., "Advances in wireless power transfer systems for roadway-powered electric vehicles". *IEEE Journal of Emerging and Selected Topics in Power Electronics*, vol. 3, n. 1, 2014, pp. 18–36, doi: 10.1109/JESTPE.2014.2343674.
- [8] Richard Gould, "Project TALAKO – demonstrating wireless taxi charging". <https://www.e-motec.net/project-talako-wireless-taxi-charging>. Accessed on May 2023.
- [9] Mazhoud, B., Gabet, T., Kadem, K., Meira, Z., Sanzel, A., Coquelle, E., Hornych, P., "Pavement integration of an inductive charging system for electric vehicles. Results of the INCIT-EV project". *Transportation Engineering*, vol. 10, 2022, doi: 10.1016/j.treng.2022.100147.
- [10] Amjad, M., Farooq-i-Azam, M., Ni, Q., Dong, M., Ansari, E. A., "Wireless charging systems for electric vehicles". *Renewable and Sustainable Energy Reviews*, vol. 167, 2022, doi: 10.1016/j.rser.2022.112730.
- [11] Cirimele, V., Diana, M., Freschi, F., Mitolo, M., "Inductive power transfer for automotive applications: State-of-the-art and future trends". *IEEE Transactions on Industry Applications*, vol. 54, n. 5, 2018, pp. 4069–4079, doi: 10.1109/TIA.2018.2836098.
- [12] Curtis Moldrich, "Volvo starts testing wireless charging technology in Gothenburg", *Car 4 May 2022*. <https://www.carmagazine.co.uk/electric/what-is-electric-car-wireless-charging-wevc-and-how-does-it-work/> Accessed on Feb. 2023.
- [13] "BMW 530e Inductive Charging Pilot Program Named Green Car Journal's 2020 Green Car Technology of the Year", *BWM press website*, Jan. 2020. https://www.press.bmwgroup.com/usa/article/detail/T0304927EN_US/bmw-530e-inductive-charging-pilot-program-named-green-car-journal%E2%80%99s-2020-green-car-technology-of-the-year?language=en_US. Accessed on Feb. 2023.
- [14] Wireless Charging System, *Nissan website*, <https://www.nissan-global.com/EN/INNOVATION/TECHNOLOGY/ARCHIVE/WCS/>. Accessed on Feb. 2023.
- [15] "Electric vehicle wireless power transfer (WPT) systems - Part 1: General requirements", *IEC 61980-1:2020*, International Electrotechnical Commission, 2020.
- [16] "Electric vehicle wireless power transfer (WPT) systems - Part 2: Specific requirements for MF-WPT system communication and activities", *IEC 61980-2:2023*, International Electrotechnical Commission, 2023.
- [17] "Electric vehicle wireless power transfer (WPT) systems - Part 3: Specific requirements for magnetic field wireless power transfer systems", *IEC 61980-3:2022*, International Electrotechnical Commission, 2022.
- [18] "Wireless Power Transfer for Light-Duty Plug-in/Electric Vehicles and Alignment Methodology", *SAE J2954_202208*, Society of Automotive Engineers, 2022.
- [19] "Electrically propelled road vehicles - Magnetic field wireless power transfer - Safety and interoperability requirements", *ISO 19363:2020*, International Organization for Standardization, 2020.
- [20] "Electric vehicle wireless power transfer - Part 1: General requirements", *GB/T 38775.1-2020*, China National Standard, 2020.
- [21] "Electric vehicle wireless power transfer - Part 2: Communication protocols between on-board charger and wireless power transfer device", *GB/T 38775.2-2020*, China National Standard, 2020.
- [22] "Electric vehicle wireless power transfer - Part 3: Specific requirements", *GB/T 38775.3-2020*, China National Standard, 2020.
- [23] "Electric vehicle wireless power transfer - Part 4: Limits and test methods of electromagnetic environment", *GB/T 38775.4-2020*, China National Standard, 2020.
- [24] "Electric vehicle wireless power transfer - Part 5: Electromagnetic compatibility requirements and test methods", *GB/T 38775.5-2021*, China National Standard, 2021.
- [25] "Electric vehicle wireless power transfer - Part 6: Interoperability requirements and testing-Ground side", *GB/T 38775.6-2021*, China National Standard, 2021.
- [26] "Electric vehicle wireless power transfer - Part 7: Interoperability requirements and testing-Vehicle side", *GB/T 38775.7-2021*, China National Standard, 2021.
- [27] "Electric vehicle wireless power transfer - Part 8: Special requirements for commercial vehicle applications", *GB/T 38775.8-2023*, China National Standard, 2023.
- [28] "Wireless Power Transfer for Heavy-Duty Electric Vehicles", *SAE J2954/2_202212*, Society of Automotive Engineers, 2022.
- [29] "Dynamic Wireless Power Transfer for both Light and Heavy Duty Vehicles", *SAE RP J2954/3*, Society of Automotive Engineers, (work in progress).
- [30] "Electric Vehicle and Plug-in Hybrid Electric Vehicle Conductive Charge Coupler", *SAE J1772_202401*, Society of Automotive Engineers, 2024.
- [31] M. Khalid, F. Ahmad, B. K. Panigrahi, and L. Al-Fagih, "A comprehensive review on advanced charging topologies and methodologies for electric vehicle battery", *Journal of Energy Storage*, vol. 53, 2022, doi: 10.1016/j.est.2022.105084.
- [32] China National Standards website, <https://www.gbstandards.org/>. Accessed on May 2023.
- [33] W. Zhang, C. C. Mi, "Compensation topologies of high-power wireless power transfer systems". *IEEE Transactions on Vehicular Technology*, vol. 65, n. 6, 2015, pp. 4768–4778, doi: 10.1109/TVT.2015.2454292.
- [34] C. S. Wang, G. A. Covic, O. H. Stielau, "Power transfer capability and bifurcation phenomena of loosely coupled inductive power transfer systems". *IEEE Transactions on Industrial Electronics*, vol. 51, n. 1, 2004, pp. 148–157, doi: 10.1109/TIE.2003.822038.
- [35] M. Zucca, et al. "Assessment of the overall efficiency in WPT stations for electric vehicles." *Sustainability*, vol. 13, n. 5, 2021, doi: 10.3390/su13052436.
- [36] "Road vehicles - Three-dimensional reference system and fiducial marks - Definitions", *ISO 4130:1978*, International Organization for Standardization, 1978.
- [37] "Interim Regulations on Radio Management of Wireless Charging (Power Transmission) Equipment", *China's Ministry of Industry and Information Technology (MIIT)*, "Interim Regulations on Radio Management of Wireless Charging (Power Transmission) Equipment", (in chinese), 2023.
- [38] J. Loncarski, V. G. Monopoli, G. L. Cascella, F. Cupertino, "SiC-MOSFET and Si-IGBT-Based dc-dc Interleaved Converters for EV Chargers: Approach for Efficiency Comparison with Minimum Switching Losses Based on Complete Parasitic Modeling", *Energies*, vol. 13, n. 17, 2020, doi: 10.3390/en13174585.
- [39] G. Wang, F. Wang, G. Magai, Y. Lei, A. Huang, M. Das, M., "Performance comparison of 1200V 100A SiC MOSFET and 1200V 100A silicon IGBT", *2013 IEEE Energy Conversion Congress and Exposition*, 15-19 Sep. 2013, Denver, CO, USA, doi: 10.1109/ECCE.2013.6647124.
- [40] "Low-voltage electrical installations – Part 4-41: Protection for safety – Protection against electric shock", *IEC 60364-4-41:2005*, International Electrotechnical Commission, 2005.
- [41] "Electrically propelled road vehicles - Part 3: Electrical safety", *ISO 6469-3:2021*, International Organization for Standardization, 2021.
- [42] "EMC test protocols for implantable cardiac pacemakers, implantable cardioverter defibrillators and cardiac resynchronization devices", *ISO 14117:2019*, International Organization for Standardization, 2019.
- [43] T. Samanchuen, K. Jirasereeamornkul, C. Ekkaravardome and T. Singhavitai, "A Review of Wireless Power Transfer for Electric Vehicles: Technologies and Standards", *2019 4th Technology Innovation Management and Engineering Science International Conference (TIMES-*

- iCON), Bangkok, Thailand, 2019, pp. 1-5, doi: 10.1109/TIMES-iCON47539.2019.9024667.
- [44] B. Alam, A. Ahmad, Y. Rafat and M. S. Alam, "A Review on Power Pad, Topologies and Standards of Wireless Charging of Electric Vehicles", 2022 International Conference on Decision Aid Sciences and Applications (DASA), Chiangrai, Thailand, 2022, pp. 827-835, doi: 10.1109/DASA54658.2022.9765274.
- [45] International Commission on Non-Ionizing Radiation Protection (IC-NIRP), "Guidelines for Limiting Exposure to Electromagnetic Fields (100 kHz to 300 GHz)", Health Physics, May 2020, 118(5):483-524. doi: 10.1097/HP.0000000000001210.