

PAPER • OPEN ACCESS

Gravity and antimatter: the AEGIS experiment at CERN

To cite this article: D. Pagano *et al* 2020 *J. Phys.: Conf. Ser.* **1342** 012016

View the [article online](#) for updates and enhancements.



IOP | ebooks™

Bringing you innovative digital publishing with leading voices to create your essential collection of books in STEM research.

Start exploring the [collection](#) - download the first chapter of every title for free.

Gravity and antimatter: the AEGIS experiment at CERN

D. Pagano^{b,c}, S. Aghion^{o,i}, C. Amsler^t, G. Bonomi^{b,c}, R. S. Brusa^{f,g}, M. Caccia^{i,j}, R. Caravita^e, F. Castelli^{i,m}, G. Cerchiariⁿ, D. Comparat^h, G. Consolati^{o,i}, A. Demetrio^d, L. Di Noto^{k,l}, M. Doser^e, C. Evans^{o,i}, M. Fani^{k,l,e}, R. Ferragut^{o,i}, J. Fesel^e, A. Fontana^c, S. Gerber^e, M. Giammarchiⁱ, A. Gligorova^t, F. Guatieri^{f,g}, S. Haider^e, A. Hinterberger^e, H. Holmestad^r, A. Kellerbauerⁿ, O. Khalidova^e, D. Krasnický^l, V. Lagomarsino^{k,l}, P. Lansonneur^s, P. Lebrun^s, C. Malbrunot^{e,t}, S. Mariazzi^t, J. Marton^t, V. Matveev^{u,v}, Z. Mazzotta^{i,m}, S. R. Müller^d, G. Nebbia^w, P. Nedelec^s, M. Oberthaler^d, N. Pacifico^e, L. Penasa^{f,g}, V. Petracek^q, F. Prelzⁱ, M. Prevedelli^x, L. Ravelli^{f,g}, B. Rienaeker^e, J. Robert^h, O.M. Røhne^r, A. Rotondi^{c,y}, H. Sandaker^r, R. Santoro^{i,j}, L. Smestad^{e,aa}, F. Sorrentino^{k,l}, G. Testera^l, I. C. Tietje^e, E. Widmann^t, P. Yzombardⁿ, C. Zimmerⁿ, J. Zmeskal^t, N. Zurlo^{c,ab}

^aLaboratory for High Energy Physics, Albert Einstein Center for Fundamental Physics, University of Bern, 3012 Bern, Switzerland

^bDepartment of Mechanical and Industrial Engineering, University of Brescia, via Branze 38, 25123 Brescia, Italy

^cINFN Pavia, via Bassi 6, 27100 Pavia, Italy

^dKirchhoff-Institute for Physics, Heidelberg University, Im Neuenheimer Feld 227, 69120 Heidelberg, Germany

^ePhysics Department, CERN, 1211 Geneva 23, Switzerland

^fDepartment of Physics, University of Trento, via Sommarive 14, 38123 Povo, Trento, Italy

^gTIFPA/INFN Trento, via Sommarive 14, 38123 Povo, Trento, Italy

^hLaboratoire Aimé Cotton, Université Paris-Sud, ENS Paris Saclay, CNRS, Université Paris-Saclay, 91405 Orsay Cedex, France

ⁱINFN Milano, via Celoria 16, 20133, Milano, Italy

^jDepartment of Science, University of Insubria, Via Valleggio 11, 22100 Como, Italy

^kDepartment of Physics, University of Genova, via Dodecaneso 33, 16146 Genova, Italy

^lINFN Genova, via Dodecaneso 33, 16146 Genova, Italy

^mDepartment of Physics, University of Milano, via Celoria 16, 20133 Milano, Italy

ⁿMax Planck Institute for Nuclear Physics, Saupfercheckweg 1, 69117 Heidelberg, Germany

^oPolitecnico di Milano, Piazza Leonardo da Vinci 32, 20133 Milano, Italy

^pInstitute of Physics and Technology, University of Bergen, Allégaten 55, 5007 Bergen, Norway

^qCzech Technical University, Prague, Brehov 7, 11519 Prague 1, Czech Republic

^rDepartment of Physics, University of Oslo, Sem Slandsvei 24, 0371 Oslo, Norway

^sInstitute of Nuclear Physics, CNRS/IN2p3, University of Lyon 1, 69622 Villeurbanne, France

^tStefan Meyer Institute for Subatomic Physics, Austrian Academy of Sciences, Boltzmannngasse 3, 1090 Vienna, Austria

^uInstitute for Nuclear Research of the Russian Academy of Science, Moscow 117312, Russia

^vJoint Institute for Nuclear Research, 141980 Dubna, Russia

^wINFN Padova, via Marzolo 8, 35131 Padova, Italy

^xUniversity of Bologna, Viale Berti Pichat 6/2, 40126 Bologna, Italy

^yDepartment of Physics, University of Pavia, via Bassi 6, 27100 Pavia, Italy

^zDepartment of Physics “Ettore Pancini”, University of Napoli Federico II, Complesso Universitario di Monte S. Angelo, 80126, Napoli, Italy



^{aa}The Research Council of Norway, P.O. Box 564, NO-1327 Lysaker, Norway

^{ab}Department of Civil Engineering, University of Brescia, via Branze 43, 25123 Brescia, Italy

E-mail: davide.pagano@unibs.it

Abstract. From the experimental point of view, very little is known about the gravitational interaction between matter and antimatter. In particular, the Weak Equivalence Principle, which is of paramount importance for the General Relativity, has not yet been directly probed with antimatter. The main goal of the AEGIS experiment at CERN is to perform a direct measurement of the gravitational force on antimatter. The idea is to measure the vertical displacement of a beam of cold antihydrogen atoms, traveling in the gravitational field of the Earth, by the means of a moiré deflectometer. An overview of the physics goals of the experiment, of its apparatus and of the first results is presented.

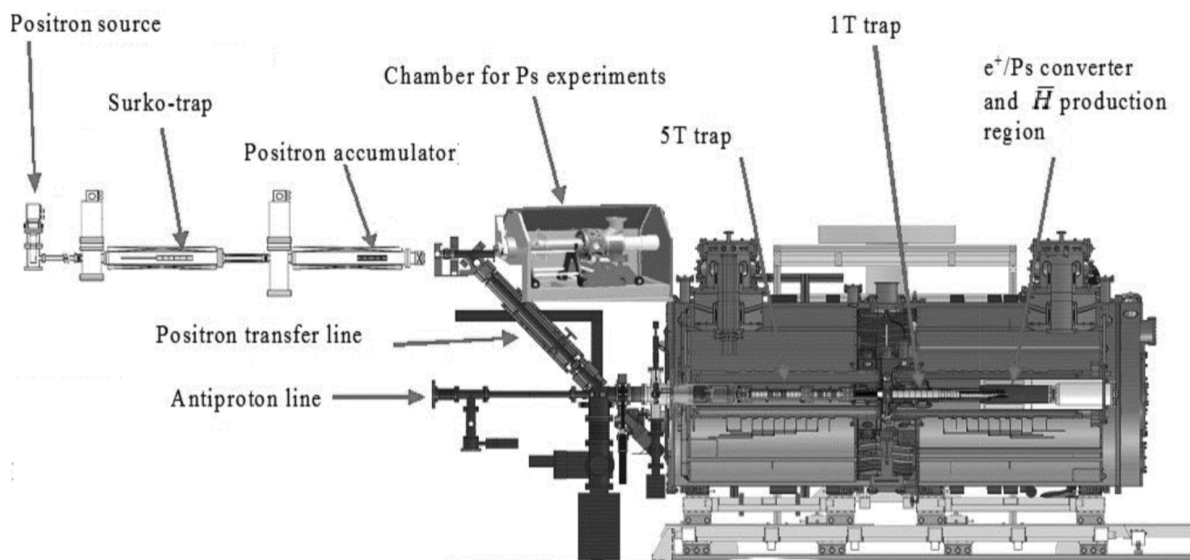

Figure 1. Scheme of the experimental setup of the AEGIS experiment (moiré deflectometer not reported).

1. Introduction

It is experimentally well known that objects fall in the gravitational field of the Earth with the same acceleration, regardless their mass or composition. Such experimental evidence led Newton to conclude, in his *Philosophiae Naturalis Principia Mathematica* [1], that inertial and gravitational masses must be necessarily equivalent. This equivalence is known as *Weak Equivalence Principle* (WEP). In 1916 Einstein extended the WEP [2] to create what is known today as the *Einstein Equivalence Principle* (EEP), which is a pillar of the General Relativity [3]. In his formulation of the equivalence principle, Einstein required the validity of the WEP as a necessary condition. Today the WEP has been widely tested experimentally and very stringent limits on its possible violation with *ordinary* matter have been set [3]. Although some experimental and theoretical arguments seem to suggest that the WEP should also hold for antimatter [4, 5, 6], they are indirect and rely on some theoretical assumptions. On the other hand, most of the attempts for a quantum theory of gravity typically predict new interactions which could violate the WEP for antimatter [7].

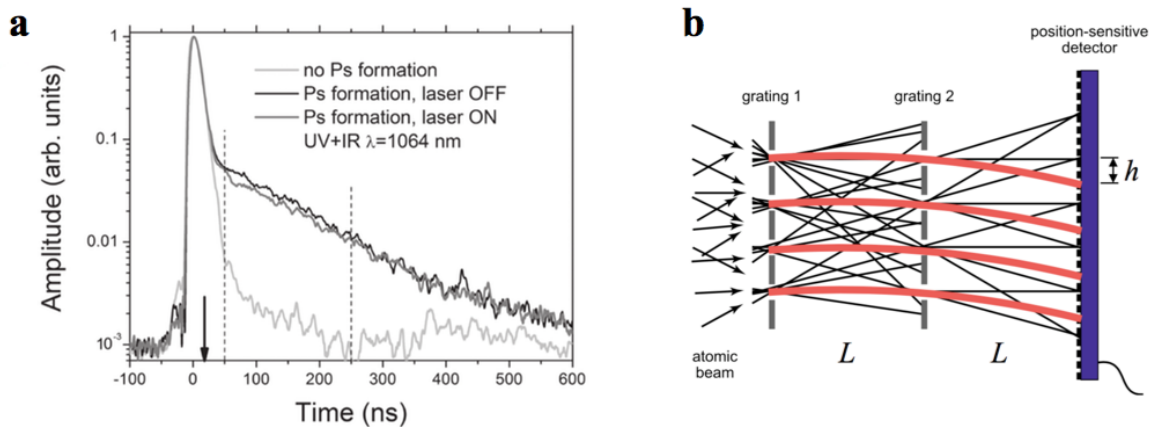

Figure 2. a) SSPALS spectrum of positronium with and without laser excitation. As excited Ps has a longer lifetime it is expected to contribute less to the beginning of the spectrum and this has been observed in data, as the *laser ON* and *laser OFF* curves show; b) Schematic of the AEGIS gravity module.

The AEGIS experiment aims at performing a direct test of the WEP on antimatter by measuring the acceleration g of a cold beam of antihydrogen in the Earth's gravitational field. The idea is to measure the vertical displacement, due to gravity, of a beam of antihydrogen passing through a moiré deflectometer coupled to a position sensitive detector (see Section 2). In the following section an overview of the AEGIS experiment is given.

2. Overview of the AEGIS experiment

Fig. 1 shows the apparatus of the AEGIS experiment. Its core consists of a ~ 5 T and a ~ 1 T superconducting solenoids, which house a Malmberg-Penning trap each [8]. The CERN's *Antiproton Decelerator* (AD) provides AEGIS with bunches of antiproton, which pass through a set of thin aluminum foils (degrader) and are caught by the trap in the 5 T magnet. Antiprotons are then cooled with sympathetic electron cooling and transferred to the 1 T trap for the \bar{H} production. Rydberg antihydrogen atoms \bar{H}^* will be produced from cold \bar{p} and Rydberg ortho-positronium Ps^* via a *charge-exchange process* [9]: $Ps^* + \bar{p} \rightarrow \bar{H}^* + e^-$. The main advantages of this process are the high cross-section (proportional to n^4 , n being the principal quantum number of Ps), the possibility of creating a pulsed beam (from a pulsed Ps production) and the production Rydberg \bar{H} atoms, which, thanks to their large electric dipole moment, can be accelerated by electric field gradients to form a beam.

Positronium (Ps) is produced by sending pulses of positrons, emitted by a Na^{22} source and bunched in a Surko-type accumulator, toward a nanoporous silica target. Its excitation to Rydberg states is achieved in two steps using two laser pulses: $1^3S \rightarrow 3^3P$ with a UV pulse with $\lambda = 205$ nm and $3^3P \rightarrow Rydberg$ with a IR pulse with $\lambda = 1709$ nm. Ps formation and excitation in AEGIS has been demonstrated [10] by the means of the SSPALS (Single Shot Positron Annihilation Lifetime Spectroscopy) technique [11] and the result is shown in Fig. 2a.

AEGIS is expected to produce \bar{H} by the end of 2017 and to perform the gravity measurement in the next years. The principle behind the measurement is to accelerate the Rydberg \bar{H} atoms (using the Stark acceleration) to form a beam and make it pass through a classical moiré deflectometer [12], composed of two gratings coupled to a position sensitive detector (Fig. 1b).

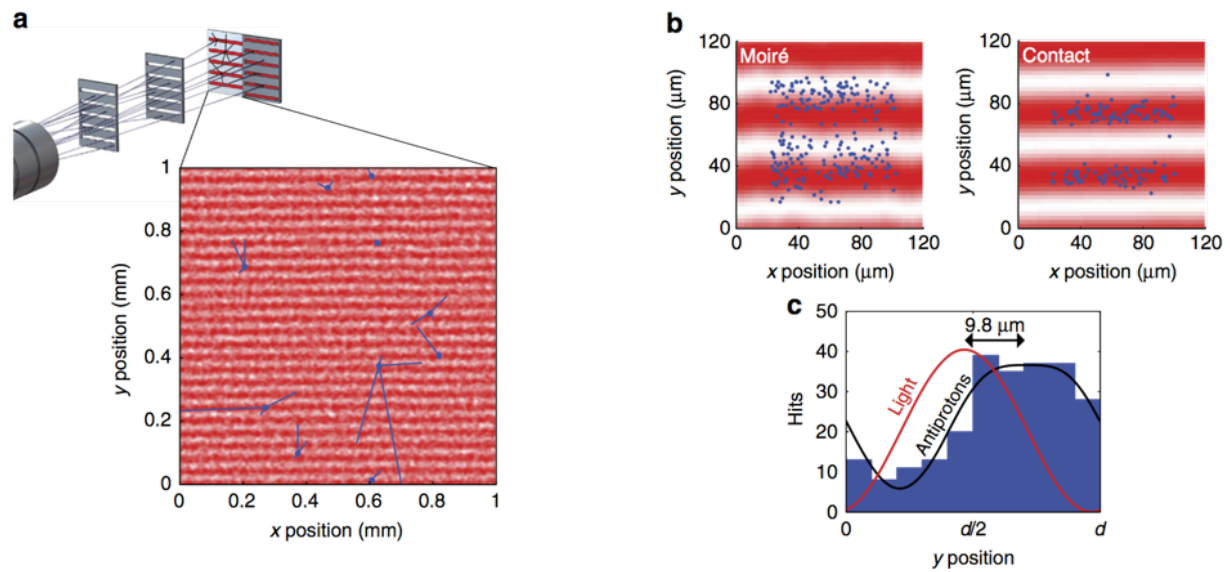

Figure 3. a) Schematic of the small-scale gravity module used [13]; b) Shadow fringe pattern on the emulsion detector produced by the moiré deflectometer (left) and the contact grating (right) [13]; c) Vertical displacement of the \bar{p} fringe with the respect to reference one created with light (in grating units d) [13].

For simple geometrical arguments, as the beam crosses the gratings it produces a fringe pattern on the detector. Because of gravity, this pattern is vertically shifted with respect to the one produced with light, which acts as a reference frame. This vertical displacement h is:

$$h = g_{\bar{H}} \left(\frac{L}{v} \right)^2, \quad (1)$$

where $g_{\bar{H}}$ is the gravitational acceleration experienced by the \bar{H} atoms, v is the component of their velocity along the direction perpendicular to the gratings, and L is the distance between gratings. As Eq. 1 shows, this strategy allows a direct measurement of $g_{\bar{H}}$, with a resolution which mainly depends on the number of reconstructed \bar{H} atoms and the detector resolution.

3. First results with a small-scale Moiré deflectometer

As proof of principle of the measurement technique, a small-scale moiré deflectometer ($L = 25$ mm), coupled to an emulsion detector, has been exposed to a beam of antiprotons from AD [13]. The sensitive detector was composed of two different regions, as shown in Fig. 2a: one with only the emulsion, and one with an additional grating in direct contact to it, whose goal was to align the measurements with antiprotons and the reference frame obtained with the light.

The positions of 241 annihilation vertexes were reconstructed with an accuracy of ~ 2 μm and compared to the reference light pattern. Fig. 2b shows the reconstruction of the annihilation vertexes of the data (blue dots), superimposed to the reference pattern (red band), as produced without (left) and with (right) the contact grating. The periodicity of data was extracted using a Rayleigh test and the y -coordinates of the reconstructed vertexes were compared (in grating units d) to that of the reference frame, as shown in Fig. 2c. The period of the moiré pattern of the antiprotons was found to be the same as the reference light pattern, but shifted by $9.8 \pm 0.9(\text{stat}) \pm 6.4(\text{syst})$ μm . From this measurement the mean force acting on the antiprotons was estimated to be $530 \pm 50(\text{stat}) \pm 350(\text{syst})$ aN, consistent with the Lorentz force due to

the residual magnetic field at the location of the moiré deflectometer, which was measured to be ~ 10 G. Although a measurement of the gravitational force on the antiprotons cannot be inferred from this data, the results prove that the use of a moiré deflectometer allows the measurement of a micrometric shift of the fringe pattern. Moreover, according to Eq. 1, the measured shift for antiprotons is expected to be comparable to the one to be produced by the gravitational force on antihydrogen, in the full-scale deflectometer ($L = 1$ m) and with $v \sim 500$ ms $^{-1}$.

4. Conclusions

At present, the validity of the WEP on antimatter has not yet been confirmed or excluded experimentally. The main goal of the AEGIS experiment is to probe the WEP with antimatter, by measuring the gravitational acceleration of a \bar{H}^* beam with an accuracy of a few percent. The experimental setup is fully in place, with the only exception of the full-scale gravity module, which is still under development. As a proof of principle of the measurement technique, a small-scale prototype of the moiré deflectometer has been exposed to a beam of antiprotons. The results not only showed that a micrometer-scale shift is observable and measurable, but also that this shift is comparable to the one to be produced by the gravitational force on antihydrogen in the final setup. The \bar{H} production in AEGIS is expected to be achieved by the end of 2017, while the first measurements of $g_{\bar{H}}$ are planned for the following years.

References

- [1] I. Newton, *Philosophiae Naturalis Principia Mathematica*, (1687).
- [2] A. Einstein, *Annalen Phys.*, **49**, 769 (1916).
- [3] C. M. Will, *Living Rev. Rel.* **17**, 4 (2014).
- [4] S. Pakvasa, W. A. Simmons and T. J. Weiler, *Phys. Rev. D* **39**, 1761-1763 (1989).
- [5] A. Apostolakis *et al.*, *Phys. Lett. B* **452**, 425-433 (1999).
- [6] M. M. Nieto and T. Goldman, *Phys. Rep.* **205**, 221-281 (1991).
- [7] J. Ponce de Leon *Int. J. Mod. Phys. D* **18**, 251273 (2009).
- [8] M. Amoretti *et al.*, CERN-SPSC-2007-017 (2007).
- [9] B. I. Deutch *et al.*, *Proc. 1st Workshop on Antimatter Physics at Low Energies* <http://lss.fnal.gov/conf/C860410/> (1986).
- [10] S. Aghion *et al.*, *Phys. Rev. A* **94**, 1 (2016).
- [11] D. B. Cassidy, S. H. M. Deng, H. K. M. Tanaka and A. P. Mills Jr. *Applied physics letters* **88**, 194105, (2006).
- [12] M. K. Oberthaler *et al.*, *Phys. Rev. A* **54**, 4 (1996).
- [13] S. Aghion *et al.*, *Nat. Commun.* **7**, 5 (2014).
- [14] A. Kellerbauer *et al.*, *NIM B* **266**, 351 (2008).
- [15] M. Doser *et al.*, *Class. Quant. Grav.* **29**, 184009 (2012)