



ALMA MATER STUDIORUM
UNIVERSITÀ DI BOLOGNA

ARCHIVIO ISTITUZIONALE DELLA RICERCA

Alma Mater Studiorum Università di Bologna Archivio istituzionale della ricerca

Digital Predistortion for Linearity Improvement of VCSEL-SSMF-Based Radio-Over-Fiber Links

This is the final peer-reviewed author's accepted manuscript (postprint) of the following publication:

Published Version:

Hadi, M.U., Traverso, P.A., Tartarini, G., Venard, O., Baudoin, G., Polleux, J. (2019). Digital Predistortion for Linearity Improvement of VCSEL-SSMF-Based Radio-Over-Fiber Links. IEEE MICROWAVE AND WIRELESS COMPONENTS LETTERS, 29(2), 155-157 [10.1109/LMWC.2018.2889004].

Availability:

This version is available at: <https://hdl.handle.net/11585/664852> since: 2019-02-14

Published:

DOI: <http://doi.org/10.1109/LMWC.2018.2889004>

Terms of use:

Some rights reserved. The terms and conditions for the reuse of this version of the manuscript are specified in the publishing policy. For all terms of use and more information see the publisher's website.

This item was downloaded from IRIS Università di Bologna (<https://cris.unibo.it/>).
When citing, please refer to the published version.

(Article begins on next page)

Digital Predistortion for Linearity Improvement of VCSEL-SSMF-based Radio-over-Fiber Links

Muhammad Usman Hadi, *Graduate Member, IEEE*, Pier Andrea Traverso, *Member, IEEE*,
Giovanni Tartarini, *Member, IEEE*, Olivier Venard, Geneviève Baudoin and Jean-Luc Polleux

Abstract— This letter unfolds a Digital Predistortion (DPD) technique that improves the linearity of limited range Mobile Front Haul links for the contemporary Long-Term Evolution (LTE) and future (5G) networks. In particular, the proposed technique is applied to Radio-over-Fiber links based on Single Mode Vertical Cavity Surface Emitting Lasers emitting at 850 nm, and Standard Single-Mode Fibers. Both, Memory and Generalized Memory Polynomial models are exploited for the predistorter and identified by utilizing Indirect Learning Architecture. The impact of the DPD technique is observed by the link performance improvement in terms of Normalized Mean Square Error and Adjacent Channel Power Ratio, referring to complete LTE frames of 10 ms occupying 5-MHz bandwidth and having 64-QAM modulation format. Furthermore, the effectiveness of the DPD approach, when varying input power levels, is investigated. The experimental results demonstrate the capability of the proposed DPD technique to achieve promising linearization performance.

Index Terms—Digital Predistortion, VCSELs, Indirect Learning Architecture, Radio-over-Fiber, LTE, ACPR, NMSE

I. INTRODUCTION

RADIO over Fiber (RoF) systems constitute a promising solution not only in long and medium range networks, but also in short-reach data networks. In the latter case, where power consumption and cost must particularly be taken into consideration [1], the perturbations due to the combination of laser frequency chirp and fiber chromatic dispersion are usually negligible [2], while those due to laser non-linearities and possible photodiode non-idealities are primary issues [3]. These can cause high inter-band and intra-bands distortion, leading to a degradation of the quality of transmission, and an increase of the interference with near channels.

From a general standpoint, Digital Predistortion (DPD)-based approaches demonstrated to be effective techniques to reduce the non-linearities in RoF systems [3,4], and in particular the Indirect Learning Architecture (ILA) has been proposed in the literature for the predistortion identification [5,6]. This architecture is based on the hypothesis that the non-linearity of the considered system is not time-varying, and ILA can therefore be applied only to RoF links, for which it can be assumed that non-linearities do not change rapidly with time. In this case, the training of the predistortion can be carried out in an off-line fashion, which also leads to reduction in cost and complexity of the predistorter.

Optical fiber systems, in particular RoF systems, based on Vertical Cavity Surface Emitting Lasers (VCSELs) that can benefit from an appropriate DPD can be found in multivariate scenarios, such as data communications, indoor wireless signal

distribution and radioastronomy [7-9]. In this letter, DPD is applied to RoF links based on Single Mode (SM) VCSELs and Standard Single Mode Fibers (SSMFs) for Long-Term Evolution (LTE) applications. The realization of this link, which satisfies the above-mentioned requirements of reduced levels of power consumption and cost, has already been demonstrated in [10], without the use of any DPD.

However, when transmitting high Peak-to-Average Power Ratio (PAPR) signals, these systems generate undesired spurious terms. These are due to relatively stable causes like nonlinear characteristic curves of laser and possibly photodiode, low dynamic range of VCSELs, and multimodal behavior of SSMFs operating at 850 nm (this latter cause would be absent if higher cost longer-wavelength VCSELs were utilized). It is therefore worth, in order to reduce these spurious terms, to investigate optimal DPD techniques devoted to linearity improvement of this class of links.

In the following, we present a DPD methodology applied to VCSEL-SSMF-based RoF links transmitting LTE standard signals, which makes use of classical Volterra series. More precisely, two alternative methods are utilized, namely Memory Polynomial (MP) model and Generalized Memory Polynomial (GMP) model using Indirect Learning Architecture (ILA). The performance of the proposed technique is evaluated in terms of reduction of Normalized Mean Square Error (NMSE) and Adjacent Channel Power Ratio (ACPR).

II. MODELING APPROACH

The application of the predistortion technique, which makes use of ILA for the estimation of the DPD coefficients, is shown in Fig. 1. In ILA, since there is no need for model assumptions, DPD identification is carried out in a single step. Moreover, the linear estimation of the coefficients makes this architecture

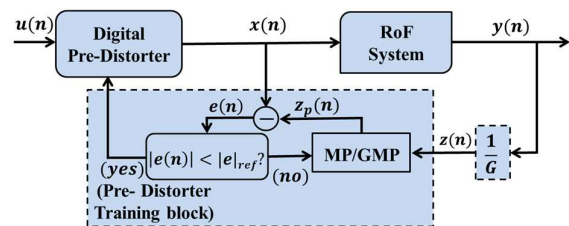

Fig. 1. DPD illustration for a RoF system using ILA

straightforward to use. Firstly, predistorter coefficients are determined in the training phase. The output of the RoF system $y(n)$, becomes input sequence to the Pre-Distorter Training block $z(n)$, defined as $z(n) = y(n)/G$ where G is the gain of the RoF link. The coefficients

can be simply and robustly estimated using any least-squares-based algorithm [11]. The predistorter training converges when the error function is minimized for the computed coefficients. Subsequently, these computed coefficients are applied to the predistorter (Digital Pre-Distorter block). The predistorter models used are based on the classical Volterra series. Both MP and GMP architectures are presented in order to draw comparisons between them.

A. Memory Polynomial Model

The first predistorter model used is based on the Memory Polynomial model that has been used as an inverse non-linear model. The MP model is a compromise between full Volterra and memoryless non-linearity as it has a diagonal memory. The detailed explanation of this technique and of the methods to get input signal matrix expression and coefficients vector is in [5]. The output of the Pre-Distorter Training block is in this case:

$$z_p(n) = \sum_{k=0}^{K-1} \sum_{q=0}^{Q-1} a_{kq} z(n-q) |z(n-q)|^k \quad (1)$$

where K is the non-linearity order, Q is the memory depth, z is the predistorter input sequence and a_{kq} are the model coefficients.

B. Generalized Memory Polynomial Model

The Generalized Memory Polynomial (GMP) model has been widely utilized for the linearization of Power Amplifiers (PAs) [6]. However, for RoF in general, and VCSELs in particular, GMP has not been yet evaluated. The basis functions in GMP model possess memory, not only for diagonal terms but also for the cross terms i.e., $x(n-q)|x(n-r)|^{k-1}$, where $q \neq r$. The GMP is expressed as:

$$z_p(n) = \sum_{k=0}^{K_a-1} \sum_{q=0}^{Q_a-1} a_{kq} z(n-q) |z(n-q)|^k + \sum_{k=1}^{K_b} \sum_{q=0}^{Q_b-1} \sum_{r=1}^{R_b} b_{kqr} z(n-q) |z(n-q-r)|^k + \sum_{k=1}^{K_c} \sum_{q=0}^{Q_c-1} \sum_{r=1}^{R_c} c_{kqr} z(n-q) |z(n-q+r)|^k \quad (2)$$

where the DPD output and input are $z_p(n)$ and $z(n)$, respectively. Similarly, a_{kq} are the complex coefficients for the signal and envelope; b_{kqr} denotes the complex coefficients for the signal and leading envelope while c_{kqr} represents signal and lagging envelope. K_a, K_b, K_c are the orders of nonlinearity, Q_a, Q_b, Q_c are the memory depths, while R_b and R_c denote the lagging and leading delay tap lengths, respectively. GMP was here applied choosing $K_a=K_b=K_c=K$, $Q_a=Q_b=Q_c=Q$, $R_a=R_b=0$

III. EXPERIMENTAL SETUP

Fig. 2 shows a block diagram of the experimental testbed used for the validation of the proposed DPD technique. A Single Mode VCSEL (Optowell), operating at 850-nm wavelength, is followed by a SSMF patch cord and a PIN photodiode, with responsivity of 0.6 A/W and 2.5-GHz bandwidth. The baseband LTE 5-MHz signals, emulated according to 3GPP Release 13 through a local MATLAB software with 64 QAM format, are oversampled (ADC in Fig.2) at a rate of 38.4 MSa/s. The sampled signals pass through the DPD block, are RF-converted

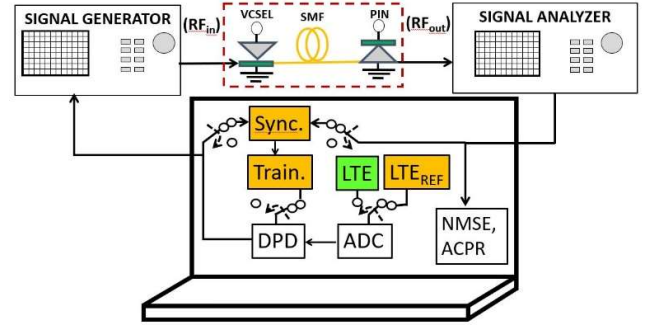

Fig. 2. Experimental setup in the DPD training phase (orange blocks active). When all the switches change position (green block active) the DPD is applied to various LTE frames.

(800 MHz) by an Agilent N5182B MXG X-Series Signal Generator (see Fig.2) and sent to the optical link.

In the DPD training phase, reference LTE frames are utilized (LTE_{REF} block in Fig. 2), the input and output sequences are first synchronized in time (Sync.block in Fig. 2). This is accomplished through an in-house developed algorithm, which finds the cross-correlation for time delay estimation, by capitalizing the Primary Synchronization Signals and Secondary Synchronization Signals present in the LTE frame [12]. The DPD coefficients are then obtained (Train. block in Fig. 2) through an in-house developed MATLAB program.

In the DPD testing phase (Fig. 2 with all switches turned to opposite position), different LTE frames are sampled, predistorted, uploaded to the Signal Generator and transmitted through the optical link. ACPR and NMSE are then evaluated and compared to the corresponding case when no DPD is applied. It is worth noticing that the DPD is tested not only for the ref signals that were used for training, but also for general LTE frames (see Sec. IV).

IV. RESULTS AND DISCUSSION

The SM-VCSEL utilized has a threshold current (I_{th}) and maximum current (I_s) of 2 mA and 5 mA, respectively. The bias point (I_{bias}) is chosen at 3 mA.

Fig. 3 summarizes the NMSE experimental results for different choices of memory depth Q and non-linearity order K using MP and GMP. Three cases have been evaluated for several Memory Depths Q (0, 1 and 2) and non-linearity orders K (3, 4, 5 and 6) applying a relatively high value of input RF power (0 dBm). It is evident that GMP leads to a higher reduction of NMSE than MP at lower orders of K . From this first test, the optimal values $Q = 1$ and $K = 3$ have been selected for both polynomial models, resulting from a tradeoff between performance achieved and complexity required to the system.

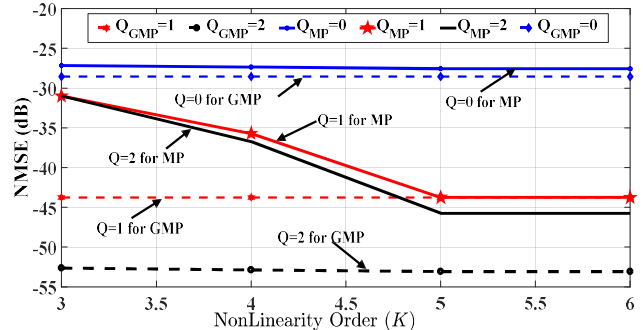

Fig. 3. Normalized Mean Square Error results for varying values of NonLinearity Order K and memory depth Q .

In Fig. 4, the Power Spectral Density (PSD) of the received signal is evaluated when MP and GMP are employed. It is evident that GMP is more effective than MP in spectral regrowth reduction. This is a validation that GMP results in better ACPR reduction than MP.

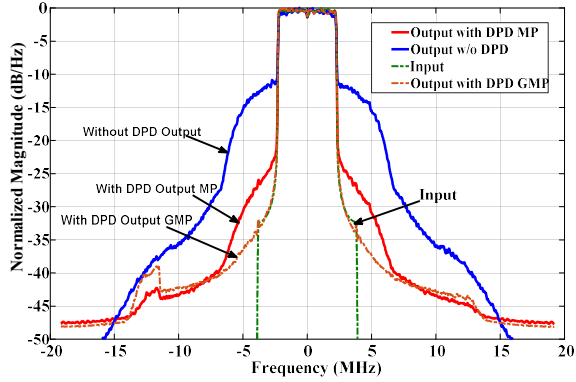

Fig. 4. PSD comparison of output without DPD and with DPD (GMP/MP) 0 dBm ($Q=1, K=3$ for both polynomial models).

In Fig. 5, the ACPR experimental results for several input powers (P_{in}) with and without DPD (MP and GMP) are reported. The linearization performance proves better for GMP than MP also in terms of reduction in the ACPR values.

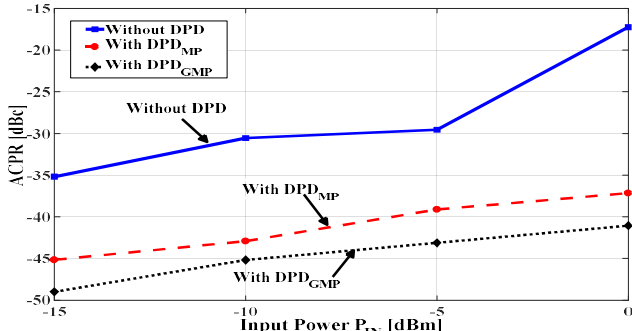

Fig. 5. ACPR experimental outcomes vs. input signal power. ($Q=1, K=3$ for MP & GMP).

Table I summarizes the experimental NMSE and ACPR results for $I_{bias} = 3$ mA with DPD (MP and GMP) and without DPD. It can be appreciated that, from a general standpoint, GMP provides a better linearization when compared to MP.

TABLE I
LINEARIZATION PERFORMANCE FOR PROPOSED DPD ($P_{in} = 0$ dBm)

Model	NMSE (dB)	ACPR (dBc)
No DPD technique	-17.10	-17.25
MP-DPD	-31.15	-37.56
GMP-DPD	-43.76	-41.06

By extending the length of the SSMF fiber span up to 1 km and applying the GMP-based DPD with $Q=1, K=3$ up to $P_{in} = 0$ dBm, the ACPR remained below the reference level of -36 dBc given by the 3GPP Standard considered. Longer link distances, and/or higher values of RF input power are admitted, provided that the model is extracted with appropriate higher

values of Q and/or K . Higher values of Q and/or K make also possible to apply the proposed DPD technique in the transmission of LTE signals, which exhibit higher bandwidth and/or modulation order with respect to the case considered.

Note that in a real implementation, the DPD can be located at the Central Office (CO), to compensate the RoF Downlink nonlinearities. Various solutions can be adopted to allow the output signal to reach the CO during the training phase. If a RoF Uplink, is utilized to this purpose, the possible presence of nonlinearities should in this case be compensated e.g. through a correspondent CO-located digital post distorter block. [3].

V. CONCLUSIONS

To the best of authors' knowledge, this work provides the first experimental demonstration of a digital predistorter based on MP and GMP for VCSEL-based RoF links. The experiments have been carried out for a VCSEL-SSMF-based RoF link, with 5-MHz Bandwidth 64 QAM LTE signals. The performance is discussed in terms of NMSE and ACPR. The results demonstrate a promising link performance improvement when either MP or GMP is exploited, already at low non-linearity order. It has been shown that GMPs achieve better linearization than MP.

REFERENCES

- [1] A. Gatto, D. Argenio, and P. Boffi, "Very high-capacity short-reach VCSEL systems exploiting multicarrier intensity modulation and direct detection," *Opt. Express* 24, 12769-12775 (2016).
- [2] G. Meslener, "Chromatic dispersion induced distortion of modulated monochromatic light employing direct detection," in *IEEE Journal of Quantum Electronics*, vol. 20, no. 10, pp. 1208-1216, Oct 1984.
- [3] A. Hekkala et al., "Predistortion of Radio Over Fiber Links: Algorithms, Implementation, and Measurements," in *IEEE Transactions on Circuits and Systems I: Regular Papers*, vol. 59, no. 3, pp. 664-672, March 2012.
- [4] F. Fuochi, M. U. Hadi, J. Nanni, P. A. Traverso and G. Tartarini, "Digital predistortion technique for the compensation of nonlinear effects in radio over fiber links," 2016 IEEE 2nd International Forum on Research and Technologies for Society and Industry Leveraging a better tomorrow (RTSI), Bologna, 2016, pp. 1-6.
- [5] M. Abi Hussein, V. A. Bohara and O. Venard, "On the system level convergence of ILA and DLA for digital predistortion," 2012 International Symposium on Wireless Communication Systems (ISWCS), Paris, 2012, pp. 870-874.
- [6] D. Morgan, Z. Ma, J. Kim, M. Zierdt, and J. Pastalan, "A generalized memory polynomial model for digital predistortion of rf power amplifiers," *Signal Processing, IEEE Transactions on*, vol. 54, no. 10, pp. 3852-3860, Oct. 2006.
- [7] P. M. Sevilla, V. Almenar, J. L. Corral, "Transmission Over SSMF at 850 nm: Bimodal Propagation and Equalization", in *Journal Of Lightwave Technology*, Vol. 35, No. 19, pp.4125-4136, October 2017.
- [8] X. Pang et al., "Performance evaluation for DFB and VCSEL-based 60 GHz radio-over-fiber system," in *Proc. 17th Int. Conf. Opt. Netw. Design Modeling (ONDM)*, Brest, France, Apr. 2013, pp. 252-256.
- [9] R. Beresford, "ASKAP photonic requirements," in *Proc. Int. Topical Meeting Microw. Photon./Asia-Pacific Microw. Photon. (MWP/APMP)*, Gold Coast, QLD, Australia, Sep./Oct. 2008, pp. 62-65.
- [10] J. Nanni, J. L. Polleux, C. Algani, S. Rusticelli, F. Perini and G. Tartarini, "VCSEL-based Radio-over-G652 Fiber System for short/medium range MFH solutions," in *Journal of Lightwave Technology*, vol. 36, no. 19, pp. 4430-4437, Oct. 2018.
- [11] L. Guan, and A. Zhu, "Optimized Low-Complexity Implementation of Least Squares Based Model Extraction for Digital Predistortion of RF Power Amplifiers," *IEEE Trans. Microw. Theory Tech.*, vol. 60, no. 3, pp. 594-603, Mar. 2012.
- [12] T. Liu, S. Boumaiza, F. M. Ghannouchi, "Deembedding static nonlinearities and accurately identifying and modeling memory effects in