

The pursuit of good microbiological conditions in domestic softeners: a new improvement

L. Bolelli, Elida Nora Ferri, Stefano Sangiorgi, Giuseppe Novelli and Stefano Girotti

ABSTRACT

Effective resin disinfection is mandatory to ensure the microbiological quality of water treated by domestic softeners. The wet and sometimes warm environment inside the softener is ideal for bacteria growth. Our research was focused on the evaluation of the microbial quality of water from softeners sanitized by chlorine solutions or by electrolytic systems. We employed the heterotrophic plate count and specific tests to monitor the presence of opportunistic and pathogenic bacteria (*Pseudomonas aeruginosa*, *Escherichia coli*, enterococci, and coliforms). Completely new devices were equipped with a commercially available electrolytic system or with a newly patented one or sanitized by automatic or manual addition of chlorine solutions. In all cases, the contamination was reduced, not completely avoided. In particular, the patented electrolytic system significantly reduced bacterial proliferation in strongly contaminated devices. Our data confirm the difficulties encountered to solve the problem of microbiological quality of softened water and offer encouraging information on new possible solutions.

Key words | chlorine, domestic softeners, drinking water contamination, electrolytic cells, resin disinfection

L. Bolelli (corresponding author)
Elida Nora Ferri
Stefano Sangiorgi
Stefano Girotti
University of Bologna,
Via S. Donato 15, 40127 Bologna,
Italy
E-mail: luca.bolelli@unibo.it

Giuseppe Novelli
Culligan Italiana SpA,
Via Gandolfi 6, 40057 Cadriano di Granarolo Emilia,
Bologna,
Italy

This article has been made Open Access thanks to the generous support of a global network of libraries as part of the Knowledge Unlatched Select initiative.

INTRODUCTION

Most people consider the quality of tap water unsatisfactory. Millions of families prefer to drink mineral water or to employ water micro filtering devices to obtain chilled, sparkling, or simply drinking water with a better taste. Water softeners reduce water hardness avoiding damage to machinery and plants. Softener and micro filtering devices have the same widespread use. Unfortunately, all systems for water distribution or treatment suffer from microflora proliferation and biofilm formation, with consequent inadequate microbiological quality of the delivered water (Chowdhury 2012; Sacchetti *et al.* 2014; Costa *et al.* 2016; Douterelo *et al.* 2016; Yari *et al.* 2018). This well-known

problem creates an obvious, sometimes unjustified concern in consumers (Hamsch *et al.* 2004; Sacchetti *et al.* 2014; Garvey *et al.* 2015; Bolelli *et al.* 2016; Brouwer *et al.* 2018; Peter & Routledge 2018). According to national and international directives establishing the limit values for the microbiological quality of water intended for human consumption, softened water included, the presence of non-pathogenic organisms is admitted in limited amounts while pathogens such as *Pseudomonas aeruginosa*, enterococci, and *Escherichia coli* must be completely absent (European Council 1998; WHO 2018).

To this aim, domestic softeners undergo manual or automatic sanitization, based mostly on chlorine solutions. However, various aspects such as the scheduling, the chlorine concentration, and the addition procedure influence the effectiveness of the process. Moreover, maintenance or

This is an Open Access article distributed under the terms of the Creative Commons Attribution Licence (CC BY 4.0), which permits copying, adaptation and redistribution, provided the original work is properly cited (<http://creativecommons.org/licenses/by/4.0/>).

doi: 10.2166/wh.2020.136

drainage activities can contaminate the softener's components, such as the outlet and the tubes downstream from the resin container, which are never reached by the flow of sanitizing solution. An electrolytic cell producing chlorine, activated by the brine flow during the resin regeneration phase represents a built-in disinfection system. The electrolytic cells now commercially available produce some chlorine, but its amount and/or the treatment interval are not suitable for effective resin sanitization. The present research was focused on the study of the performance of a newly patented electrolytic system (Novelli & Scaranari 2019). The microbiological quality of softened water sanitized by the current methods and by the new device was monitored, obtaining promising results.

METHODS

Softeners and experimental setups

We employed eight new domestic water softeners (WSs) 'Medallist M910' model (Culligan Italiana SpA, Cadriano, BO, Italy) (Figure 1, left). A softener includes the ionic exchange resin container (A) and the brine container (B) connected by a pipe where the commercial electrolytic system is placed when present. Conversely, the newly patented electrolytic system was placed directly inside the brine container.

We planned two experimental periods. First, we compared the effectiveness of three sanitization strategies:

1. Automatic, by a commercially available electrolytic cell (E.C.) (WS no. 1).
2. Automatic, by a kit system dosing directly in the resin container, at any regeneration phase, an NaClO solution at 15, 7, and 4% (WSs no. 2, 3, and 4, respectively).
3. Manual, by adding into the resin container, once a month, 100 mL of an NaClO solution at 15, 7, and 4% (WSs no. 5, 6, and 7, respectively).

The WS no. 8 was the control device, without sanitization.

WSs were connected in parallel to a mechanical filter blocking the particulate impurities, in turn, connected to the main supply (see Figure 1, middle).

During the second period, we evaluated the performance of the new electrolytic system. The WSs no. 1, 2, and 3 were manually sanitized by 14% NaClO solution and each one equipped with the new electrolytic cell. It was activated every 4 h for 2, 8, and 15 min, respectively (see Figure 1, right). The WS no. 8 was still the control, without sanitization. After 1 month of activity, we switched off the softeners, simulating 7 weeks of inactivity. We restarted the WSs without any sanitization.

Water sampling

Once a week, two water samples (type A and B, 100 mL) were collected in sterile containers (IDEXX Laboratories, Inc., Westbrook, ME, USA) following the Watercoolers

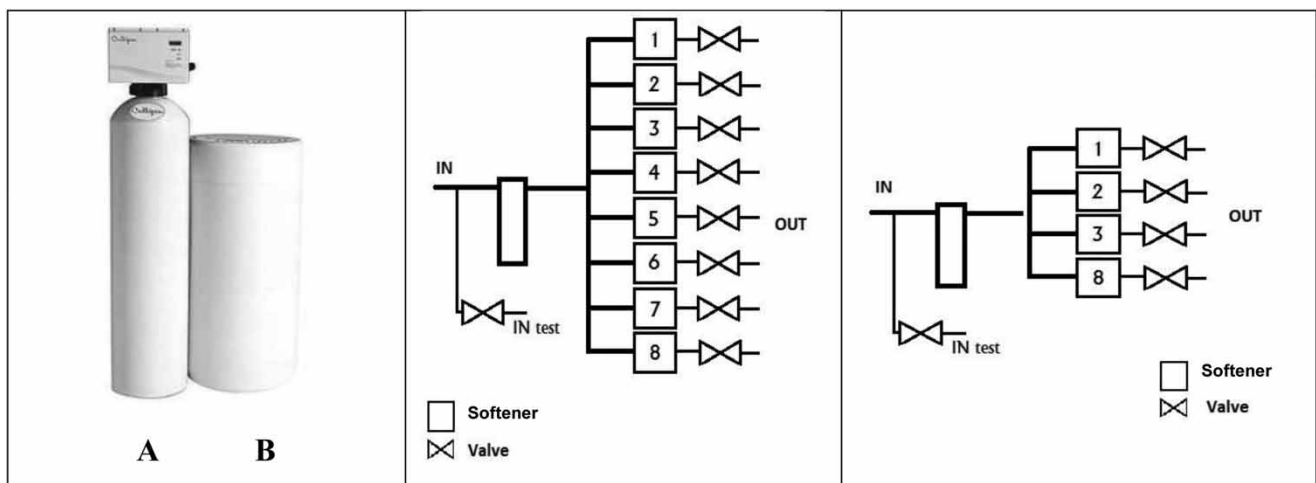

Figure 1 | Left: The Medallist softener. (A) The resin container and (B) the brine container. Middle: the eight WSs arrangement in the first experimental setup. Right: the four WSs arrangement in the second experimental setup.

Europe Association (2011) procedure. Briefly: once a day for 3 days, we drained off 60 L of water, five times the whole content of the resin container. The day after, we drained off 6 L of water before to collected the first sample (sample A). Immediately after, we drained off 120 L of water and we collected the second sample (sample B).

Each week, we collected from the mains supply a sample of influent water (sample A) and a second one (sample B) after 24 h.

Microbiological assays

The heterotrophic plate count (HPC) of colony-forming units (CFUs) was performed according to European and Italian Standard methods (Bonadonna & Ottaviani 2007; Watercoolers Europe Association 2011). We assumed the value of 100 CFU/mL at both 22 and 37 °C as the admitted threshold. To identify the presence of pathogens we employed enzymatic, colorimetric/fluorescent kit tests based on the Most Probable Number methodology: the

'Colilert-18' (coliforms and *E. coli*), the 'Enterolert' (enterococci), and the 'Pseudoalert' (*P. aeruginosa*) used according to the manufacturer's instructions (IDEXX Laboratories, Inc., Westbrook, ME, USA). The positive tests were yellow color/no fluorescence for coliforms and yellow color/fluorescence for *E. coli* using the Colilert-18 kit. By using the Enterolert kit, green color indicated the presence of Enterococci and the appearance of fluorescence in the Pseudoalert kit revealed the presence of *P. aeruginosa*.

RESULTS

The analyses on the samples collected during the first research period revealed that about half of the A-type samples did not respect the admitted limits concerning or the CFUs or the presence of pathogens. The B samples resulted in definitely below the legal limits. We reported in Table 1 the series of cases of the A-type samples, which can be considered a risk for human health.

Table 1 | Microbiological data indicating a risk for human health, obtained from the analysis of the A-type samples from the first experimental period (weeks 1–18)

	Weeks																	
	1	2	3	4	5	6	7	8	10	11	12	13	14	15	16	17	18	
Water	1	■		▲								●	●	●	●	●	●	
	2		▲				▲	▲	▲						○	○	○	○
softeners	3	■																
	4								▲	▲	▲	▲	▲	▲	▲	▲	▲	
	5																	
	6																	
	7									■	■	■	■	■	■	■	■	
	8																	

Both samples of influent water (A and B) resulted in negative.

Presence of *P. aeruginosa* (▲), presence of coliforms (■). In both cases, the admitted limit was 0 CFU/100 mL. HPCs above the threshold at 22 °C (○) and 37 °C (●). The threshold value was in both cases 100 CFU/mL.

The quantitative data reported in Table 2 concern both the A- and B-type samples collected during the 18th week. They indicate the performance of the different sanitization strategies. As expected, the B samples were always less contaminated than the respective A ones. The 120 L of water drained off before collecting the B samples were able to remove the main part of bacteria proliferating on the inner surfaces of the device.

During the second experimental period, we employed only four devices, no. 1, 2, and 3, sanitized by the new electrolytic system activated for 2, 8, and 15 min, respectively. The results from the microbiological tests on all the A samples collected during this period are reported in Table 3. The control, never sanitized, was the WS no. 8.

To evaluate the possibility of correlating a high number of CFUs with the presence of pathogens, we calculated the Pearson index of correlation between the CFU values both at 22 and 37 °C and the number of pathogens identified in the A samples. As shown in Table 4, A, in all cases the Index values were far from 1, clearly demonstrating that the presence or absence of pathogens was independent of the total plate counts.

Moreover, we compared by the Pearson index of correlation, the contamination levels in the control device (WS no. 8) and the WS no. 1, equipped with the commercial electrolytic cell. The results are shown in Table 4, B1. The same

Table 2 | Results of the CFU counts for the A and B samples collected during the last week of the first experimental period

Water softeners Sample	HPC (CFU/mL)		<i>P. aeruginosa</i> (CFU/100 mL) A/B	Coliforms (CFU/100 mL) A/B
	22 °C	37 °C		
	A/B	A/B		
1 E.C. ^a	1,536/135	1,032/106	0/0	0/0
2 (Kit 15%)	102/11	103/9	4/0	0/0
3 (Kit 7%)	25/2	32/3	6/0	0/0
4 (Kit 4%)	22/1	17/3	0/0	50/2
5 (Man 15%)	93/7	91/6	0/0	0/0
6 (Man 7%)	85/4	77/1	0/0	6/0
7 (Man 4%)	119/10	182/8	0/0	0/0
8 Control	764/82	844/74	0/0	0/0

The sanitizing solutions (4, 7, and 15% of NaClO) were introduced automatically at each regenerating phase (kit × %) or manually once a month (man × %). The A and B samples collected from the main supply were always negative for colony growth.

Bolded values were those above the respective admitted limits (see Table 1).

^aE.C. = electrolytic cell.

Table 3 | Data obtained from the microbiological analyses on the A samples collected during the second part of the investigation

	1st week	2nd week	3rd week	4th week ^a	12th week	13th week
WS HPC (CFU/mL) at 22–37 °C						
1	684–556	676–508	1,344–1,004	147–52	61–46	131–155
2	13–15	14–13	48–21	12–44	26–7	12–11
3	21–9	26–7	41–35	50–19	49–6	10–15
8	43–32	122–41	106–44	99–34	372–97	108–36
WS Specific tests						
1						
2	■	■	■	■		
3	■▲	■▲	■▲	▲	■▲	■▲
8		■	■	■	■▲	■

Bolded values were above the respective admitted limits (see Table 1).

^aDuring weeks 5–11, no water samples were collected and the softeners were switched off. Presence of *P. aeruginosa* (▲), presence of coliforms (■).

statistical index was employed to compare the control device's data with those obtained for samples from the devices no. 1–3 during the second experimental period. The Pearson index values obtained in this case are reported in Table 4, B2.

DISCUSSION

During the first experimental period, the presence of *P. aeruginosa* and/or coliforms in samples from four WSs were detected from the beginning in spite of the very low values of HPCs. Although the devices were new and never used, this was not enough to ensure that they were free from pathogens contamination.

At the end of the 3rd week, the presence of *P. aeruginosa* was detected in water samples from all softeners, accompanied by an increase in HPCs. The sanitization of the outlet in all WSs resulted in a reduction of the HPCs and in the disappearance of *P. aeruginosa* from seven out of eight devices. The improper manipulation of the outlets during sampling activity was responsible for this contamination. This is the main way for bacterial contamination of water dispensing devices.

No sample of the 9th week was collected because the softeners underwent the substitution of all valves. The

Table 4 | Pearson index of correlation between the CFU values both at 22 and at 37 °C

	E.C.	Kit 15%	Kit 7%	Kit 4%	Man 15%	Man 7%	Man 4%	Control
A								
CFU 22 °C								
<i>P. aeruginosa</i>	-0.13	0.38	0.27	-0.02	-0.13	-0.16	-0.09	-0.22
Enterococci	-0.14	0.00	0.00	0.00	0.00	0.00	0.00	0.00
Coliforms	0.00	0.00	0.23	0.18	0.00	0.34	0.31	-0.08
<i>E. coli</i>	0.00	0.00	0.00	0.00	0.00	0.00	0.00	0.00
CFU 37 °C								
<i>P. aeruginosa</i>	-0.17	0.00	0.30	0.41	-0.14	-0.17	-0.10	-0.37
Enterococci	-0.18	0.00	0.00	0.00	0.00	0.00	0.00	0.00
Coliforms	0.00	0.00	0.29	0.49	0.00	0.35	0.13	-0.15
<i>E. coli</i>	0.00	0.00	0.00	0.00	0.00	0.00	0.00	0.00
B1								
		Control				Control		
CFU 22 °C					CFU 37 °C			
WS no. 1	0.50				WS no. 1	0.96		
B2								
		Control				Control		
CFU 22 °C					CFU 37 °C			
WS no. 1	-0.44				WS no. 1	-0.33		
WS no. 2	0.22				WS no. 2	-0.33		
WS no. 3	0.50				WS no. 3	0.23		

A: Pearson index of correlation values obtained by comparing the CFUs and the number of pathogens in A samples collected during the first experimental period.

B1: Pearson index of correlation values for CFUs in samples from the Control vs. those in samples from the WS no. 1 (current electrolytic cell). B2: the same index of correlation values obtained between the Control's samples data and those from the WSs no. 1, 2, and 3 (newly patented cell) samples.

samples collected during the 10th week showed the presence of coliforms in two softeners and of *P. aeruginosa* in three of them. The contamination occurred during the maintenance manipulations since the technicians did not use sterile gloves. These data, together with those concerning the outlets' sanitization, confirmed that great attention must be paid to hygiene rules during any interventions on the softeners' internal components or on the outlet.

The bacterial contamination significantly increased in the WSs no. 1 and 8 during the following 8 weeks. Concerning the control device, this was not surprising since no sanitization was carried out on it. Otherwise, the increasing contamination in WS no. 1 revealed a serious problem in the sanitizing efficacy of the currently used electrolytic system.

This statement was confirmed by the Pearson index of correlation values obtained for the two series of CFU values in samples from these devices (Table 4, B1).

Especially at 37 °C, the agreement between the data was very good, confirming the negligible effect produced by the presence of the electrolytic cell. The reasons for the low effectiveness of the commercial electrolytic system can be ascribed to its placement and activation time. Placed inside the pipe connecting the two containers, the electrolytic cell interacts with only a little volume of brine. Moreover, the contact time is very short, corresponding just to the resin regeneration phase.

The automatic and manual sanitization resulted, at all concentrations, in a better effect than the electrolytic system (Table 2). Nevertheless, *P. aeruginosa* contamination was found in WS no. 2 samples. *P. aeruginosa* and coliforms were present in samples from WS no. 3 and 4. The addition of NaClO solution was not active enough to remove the contamination by pathogens. The formation of biofilms on the wet surfaces and the particular resistance of *P. aeruginosa*

can be the reasons for this failure. The presence of high values of CFU is not correlated with the presence of pathogens (Table 4, A), which appearance occurred frequently in concurrence with low heterotrophic plate counts.

The sanitization performed before starting the second experimental period reduced but did not set to zero the HPCs. After this treatment, the samples from the strongly contaminated WS no. 1 showed values still above the admitted threshold. At least the amount of *P. aeruginosa* and coliforms was reduced by more than half; total coliforms resulted under the legal limit.

The 7-week stop did not stimulate bacterial proliferation, as it was expected. On the contrary, samples drained during the first week after the restart showed, with the only exception of the Control, HPCs lower or similar to those of the samples collected just before the stop (Table 3). The new electrolytic system was able to maintain HPC values under the admitted threshold in WS no. 2 and 3. In WS no. 1, this result was not achieved, probably because in addition to its strong contamination, its electrolysis activation period was the shortest among all. The Pearson index of correlation calculated for CFUs in water samples from the WSs no. 1–3 and those from the Control confirmed the highly significant difference in the microbiological water quality produced by the application of the new electrolytic cell.

Unfortunately, none of the tested sanitization methods was able to eradicate the contamination from *P. aeruginosa* and/or coliforms, whose presence was not positively correlated to the HPC values (Table 3).

CONCLUSIONS

This experimental work offered various helpful information. The data obtained during the first experimental period confirmed that the currently used electrolytic systems are ineffective in controlling the bacterial proliferation. In conclusion, to ensure acceptable bacterial contents in water from commercial devices, annual maintenance of the device by chlorine solution (manual or automatic) is recommended.

The newly patented electrolytic system offered good perspectives to solve the problem. It proved to be effective in

maintaining the HPCs under the admitted limit when the starting contamination level is quite low, as it must be for new devices, and it is activated at regular intervals longer than a few minutes. Further studies will be necessary to assess the best working parameters for the new electrolytic system. With the collaboration of the manufacturer, the study will continue changing the material of the electrode to increase the efficiency of the sanitization process. With this new configuration of the device, we will attend the increase of chlorine production to reduce the bacteria proliferation.

ACKNOWLEDGEMENTS

Culligan Italiana SpA provided financial support for the conduct of the research, lent the devices, and supplied the consumables employed during the experimental tests. It participated in the study design and agreed to the decision to submit the article for publication.

REFERENCES

- Bolelli, L., Ferri, E. N. & Girotti, S. 2016 Control of microbial contamination in drinking water from microfiltering dispensers by dialysis ultrafilters. *Ovidius University Annals of Chemistry* **27** (2), 87–93. <https://doi.org/10.1515/auoc-2016-0014>.
- Bonadonna, L. & Ottaviani, M. 2007 *Metodi analitici di riferimento per le acque destinate al consumo umano ai sensi del DL.vo 31/2001. Metodi microbiologici. (Reference Analytical Methods for Water Intended for Human Consumption According to the Italian Legislative Decree 31/2001. Microbiological Methods)*. Report of Istituto Superiore di Sanità ISTISAN 07/5, Rome, Italy. Available from: <http://old.iss.it/publ/index.php?lang=1&id=2074&tipo=5> (accessed 30 May 2019).
- Brouwer, S., van der Wielen, P. W. J. J., Schriks, M., Claassen, M. & Frijns, J. 2018 Public participation in science: the future and value of citizen science in the drinking water research. *Water* **10**, 284–299. <https://doi.org/10.3390/w10030284>.
- Chowdhury, S. 2012 Heterotrophic bacteria in drinking water distribution systems: a review. *Environmental Monitoring and Assessment* **184** (10), 6087–6137. <https://doi.org/10.1007/s00253-015-7155-3>.
- Costa, D., Mercier, A., Gravouil, K., Lesobre, J., Verdon, J. & Imbert, C. 2016 Occurrence and diversity of both bacterial and fungal communities in dental unit waterlines subjected

- to disinfectants. *Pathogens and Disease* **74** (7). <https://doi.org/10.1093/femspd/ftw094>.
- Doutereho, I., Jackson, M., Solomon, C. & Boxall, J. 2016 [Microbial analysis of in situ biofilm formation in drinking water distribution systems: implications for monitoring and control of drinking water quality](#). *Applied Microbiology and Biotechnology* **100**, 3301–3311. <https://doi.org/10.1007/s00253-015-7155-3>.
- European Council 1998 Council directive 98/83/EC of 3 November 1998 on the quality of water intended for human consumption. Official Journal of European Communities. **L330**, 32–54.
- Garvey, M., Rabbitt, D. & Rowan, A. N. 2015 [Pulsed ultraviolet light inactivation of *Pseudomonas aeruginosa* and *Staphylococcus aureus* biofilms](#). *Water and Environment Journal* **29**, 36–42.
- Hamsch, B., Sacré, C. & Wagner, I. 2004 [Heterotrophic plate count and consumer's health under special consideration of water softeners](#). *International Journal of Food Microbiology* **92**, 365–373. <https://doi.org/10.1111/wej.12088>.
- Novelli, G. & Scaranari, R. 2019 Apparato addolcitore di acqua (Water Softener). Italian Patent Number: 61.C4160.12.EP.1 – 2019-08-21 Pub EP3527537A1.
- Peter, A. & Routledge, E. 2018 [Present-day monitoring underestimates the risk of exposure to pathogenic bacteria from cold-water storage tanks](#). *PLoS ONE* **13** (4), e0195635. <https://doi.org/10.1371/journal.pone.0195635>.
- Sacchetti, R., De Luca, G., Dormi, A., Guberti, E. & Zanetti, F. 2014 [Microbial quality of drinking water from microfiltered water dispensers](#). *International Journal of Hygiene and Environmental Health* **217**, 255–259. <https://doi.org/10.1016/j.ijheh.2013.06.002>.
- Watercoolers Europe Association 2011 *Standard Methodology for the Examination of Dispensed Water of Point of Use & Point of Entry Water Coolers Installed Inside Buildings*. Available from: www.watercoolerseurope.eu (accessed 30 May 2019).
- World Health Organization 2018 *A Global Overview of National Regulations and Standards for Drinking-Water Quality*. World Health Organization Licence: CC BY-NC-SA 3.0 IGO, Geneva, Switzerland.
- Yari, A. R., Mohammadi, M. J., Geravandi, S., Doosti, Z., Matboo, S. A., Jang, S. A. & Nazari, S. 2018 [Assessment of microbial quality of household water output from desalination systems by the heterotrophic plate count method](#). *Journal of Water and Health* **16** (6), 930–937. <https://doi.org/10.2166/wh.2018.082>.

First received 4 June 2019; accepted in revised form 27 December 2019. Available online 12 March 2020