



ALMA MATER STUDIORUM
UNIVERSITÀ DI BOLOGNA

ARCHIVIO ISTITUZIONALE
DELLA RICERCA

Alma Mater Studiorum Università di Bologna Archivio istituzionale della ricerca

Experimental characterization of a prototype of bidirectional substation for district heating with thermal prosumers

This is the final peer-reviewed author's accepted manuscript (postprint) of the following publication:

Published Version:

Experimental characterization of a prototype of bidirectional substation for district heating with thermal prosumers / Pipiciello M.; Caldera M.; Cozzini M.; Ancona M.A.; Melino F.; Di Pietra B.. - In: ENERGY. - ISSN 0360-5442. - ELETTRONICO. - 223:(2021), pp. 120036.1-120036.15. [10.1016/j.energy.2021.120036]

Availability:

This version is available at: <https://hdl.handle.net/11585/870756> since: 2024-05-14

Published:

DOI: <http://doi.org/10.1016/j.energy.2021.120036>

Terms of use:

Some rights reserved. The terms and conditions for the reuse of this version of the manuscript are specified in the publishing policy. For all terms of use and more information see the publisher's website.

This item was downloaded from IRIS Università di Bologna (<https://cris.unibo.it/>).
When citing, please refer to the published version.

(Article begins on next page)

Experimental characterization of a prototype of bidirectional substation for district heating with thermal prosumers

Mauro Pipiciello^a, Matteo Caldera^{b,*}, Marco Cozzini^a, Maria A. Ancona^c, Francesco Melino^c, Biagio Di Pietra^b

^a Institute for Renewable Energy, EURAC Research, Viale Druso 1, Bolzano 39100, Italy

^b Energy Efficiency Unit Department, ENEA, Via Anguillarese 301, Rome 00123, Italy

^c Alma Mater Studiorum, Università di Bologna - DIN, Viale del Risorgimento 2, Bologna 40136, Italy

Abstract

The prosumer, already widespread in the electrical sector, is still uncommon in the district heating (DH) sector. Nevertheless, this figure can potentially provide a relevant contribution to increase the renewable fraction of heat and to decrease the fossil fuel consumption, hence enhancing sustainable and efficient district heating. Moreover, prosumers are more informed and responsible towards energy production and energy savings. In order to enable the two-way heat exchange, the thermal substation at the interface between the prosumer and the DH network must be properly upgraded.

The present paper aims at providing a comprehensive contribution to the design and testing of an actual bidirectional substation for district heating, focusing on the hydraulic configuration and on the control strategies. The realized substation primarily fulfils the prosumer's heat demand and supplies the excess heat to the DH network only if it is available at the temperature contractually defined with the DH operator, while it uses the network as a source if the local production is not sufficient to cover the user's heat demand. The bidirectional substation can be connected to a generic micro-generation system, e.g. solar thermal or heat recovery units. The prototype, with a technology readiness level TRL 4, allows a simultaneous two-way heat exchange with the network. An extensive test campaign has been carried out in order to evaluate its dynamic behavior both from energetic and hydraulic points of view.

Keywords

District heating; thermal prosumers; bidirectional substation; feed-in substation; solar district heating

1. Introduction

District heating (DH) has evolved considerably over the last four decades, and the current trend is to improve the performance by decreasing the supply temperature and increasing the share of renewable energy sources (RES) and waste heat. In Europe, Directive 2012/27/EU (i.e. the so called *Energy Efficiency Directive*) recognized the importance of increasing the renewable share in DH, and introduced the concept of efficient district heating and cooling, i.e. a district heating or cooling system using, alternatively, at least 50% renewable energy, 50% waste heat, 75% cogenerated heat or 50% of a combination of such energy and heat [1]. In particular, low temperature DH is an emerging technology that will contribute to the achievement of sustainable energy systems, and will pave the way for *smart thermal grids*, i.e. thermal networks connecting buildings, which will be served from centralized plants and from distributed production units including individual contributions from the connected buildings, preferably from renewables and waste heat recovery [2]. In such a context, DH will play an important role in balancing fluctuating RES and in exploiting waste heat sources and large-scale thermal storages [3].

In order to promote such innovation, the involvement of stakeholders is fundamental. According to a recent survey to investigate stakeholders' perception and motivation on smart DH [4], there is flexibility potential in utilizing distributed heat sources, but there are technical, policy and economic challenges to overcome. The energy transition has paved the way to a new stakeholder: the prosumer. Prosumers are both consumers and producers of energy, and they can contribute to increase the flexibility of the energy supply [5]. With prosumers, DH evolves in a bidirectional, or active thermal network. The success of this new paradigm requires a change in thinking by both network operators and customers. The former should permit third party access to the network, whereas the latter should start viewing their costs for heat rejection as potential revenues and be more sensitive in an efficient management of energy [6]. Actual experiences demonstrate how the transformation from consumers to prosumers improves their perception of energy use and their relation with the environment, and they become more responsible and informed [7].

Regulations and policies strongly affect the evolution and development of DH configurations [8]. A proper regulation of the pricing of heat delivered into the district heating network (DHN) will play a crucial role, e.g. dynamic pricing could be an interesting option to foster feeding heat into the DHN [9]. Moreover, the introduction of a mechanism of incentives/penalties may encourage the optimal operation of substations and space heating systems aimed at rewarding low-temperature space heating and supporting flexible and efficient operation of DH systems [10].

While nowadays prosumers are widespread in the electricity system, in particular with the diffusion of photovoltaics among small customers and thanks to dedicated support schemes and a proper regulatory framework, they are uncommon in the DH sector. Nevertheless, thermal prosumers connected to DHN have been widely investigated in the literature, and common findings foresee great potential for prosumers' contributions [11]-[12]. Different numerical models have been implemented to evaluate the energetic, environmental and economic implications of the integration of decentralized RES and thermal storages in low temperature DHN including existing networks and evaluating scenarios with thermal prosumers. Brange et al. [13] considered a case study in Malmö, Sweden, where small-scale prosumers delivered heat to the network either with a HP or directly, according to the supply temperature, reporting a potential of excess heat around 50-120% of the annual heat demand. Di Pietra et al. [14] simulated prosumers with local solar collectors connected to a small DHN with the "net metering" configuration, founding that it could lead to an increase of heat supplied by solar collectors up to 100%. Kauko et al. [15] studied the impacts of different scenarios of DH in Trondheim, Norway, including heat supplied by prosumers in a low-temperature DHN resulting in a reduction up to 25% in the heat demand from the central heating plant and reduced heat losses due to overall lower distances from prosumers to consumers. Data centers are good candidates as large energy prosumers in DH systems [16], since they produce large quantities of waste heat with an almost stable profile during the day, which represent the optimal conditions for decentralized heat supply. Waste heat utilization has great potential in DHNs, since it can decrease the utilization hours of both cogeneration plant

and backup boilers, and lead to operational costs savings [17]. Nevertheless, the energy and economic performance of active DHNs is strongly dependent on the geographical locations and climatic conditions [18].

As regards solar district heating (SDH), most of the SDH systems in Europe are located in Denmark, Austria, Germany and Sweden according to the Solar District Heating platform [19]. Simulations on SDH networks have demonstrated that decentralized feed-in heat can potentially cover a relevant part of the total demand, especially during summer [20]-[21]. Donovan et al. [22] proposed a concept with a branch of the network supplied by the return pipeline of a high temperature network. The contribution of the storage tank and the distributed solar collectors increased the RES fraction of the DHN, while the decrease in the operating temperatures resulted in a 12% reduction in the network thermal loss. Nevertheless, it is important to minimize the influences among nearby prosumers, and the effects of the thermal capacity of the network as well [23]. García et al. [24] showed the benefits of a domestic prosumer equipped with photovoltaic-thermal hybrid solar collectors integrated by a HP and connected to a low temperature DH, while Postnikov et al. [25] found potential economic benefits from the interaction between prosumers and the DHN.

Moreover, numerous algorithms have been developed to optimize the sizing and operation of DHNs with prosumers. Ancona et al. [26] developed IHENA, a software aimed at the design and/or performance prediction of SDH networks with bidirectional substations connected to the network. Ben Hassine [27] developed a model to calculate the pressure and temperature profiles in a network integrated with distributed ST collectors, and investigated the issues related to flow control and differential pressure operation of the pumps. The presence of prosumers requires DHN operators to develop accurate models in order to forecast not only thermal request profiles [28]-[29]-[30] but also the distributed thermal production at the prosumers' sites, and including the network dynamics and thermal transients as well [31]. According to some results, ST heating may provide 30–90% of the demand for conventional houses in winter and summer, respectively [32]. Optimization models have been implemented to find the dispatching strategy for the different heat sources, to minimize the operational costs and to size the solar collectors and thermal plants and the optimal capacity of storages [33]. Delgado et al. [18] presented a multiobjective optimization for operational CO₂ emissions and lifecycle costs of residential prosumers supplying heat and electricity in the Netherland and Finland, with and without net-metering, achieving economic and emission reductions. Wang [34] proposed an optimization model to achieve the lowest power consumption of decentralized DH pumps connected to a DHN and, at the same time, to fulfil the hydraulic head demands of customers.

As anticipated, temperatures play a major role in the overall efficiency of the DH system. In fact, high temperature differences between the supply and return pipes are beneficial to limit the flowrates and hence the pumping power, while low temperatures in the return pipe are desirable since they increase heat production efficiency at the DH thermal plant, and decrease the network heat losses. These design rules affect the performance of bidirectional DH, since heat delivered by thermal prosumers strongly depends on the temperatures of the network, being low temperatures able to enhance distributed heat supply from renewables. In this context, different solutions have been investigated in order to reduce the return temperature in DHNs, e.g. optimized substation control for space heating [35] or an energy cascade connection of a low-temperature DHN to the return line of a high-temperature DHN [36]. The latter solution is feasible if the low-temperature DHN serves low-energy buildings with radiant floors, in which domestic hot water may be produced with the integration of HP decentralized at the consumers' site [6] or at neighborhood scale, with substations equipped with storage tanks [37]. Paulus and Papillon [38] analyzed nine hydraulic configurations for substations connected to a decentralized SDH network, showing the influence of the DHN return temperature on the ST efficiency and on the levelized cost of solar energy.

On the other side, active DH has some limitations that affect the management of the network and the exploitable fraction of renewables. First of all, the un-programmable nature of RES, then the delay between the heat demand and the availability of local heat. This drawback can be mitigated, and extended use of surplus heat may be enhanced, by using thermal storages [15], [23]. In this respect, decentralized micro-cogeneration may be an interesting alternative, since it guarantees stable supply temperatures, and it can

1 feed heat into the DHN with programmable profiles. Another limitation is that most of the decentralized
2 excess heat is produced during summer when the heat demand is low [13]. Furthermore, if the presence of
3 prosumers improves the flexibility of DHNs, it also makes their operation and management more complex,
4 thus requiring complex controls and real-time interactions. Novel control and operation strategies aimed at
5 reducing energy use in the DH plant and at promoting the integration of multiple distributed heat sources
6 are required in order to keep proper values of temperatures and flowrates in the network [39]-[40]. Possible
7 innovative control strategies rely on model predictive controls [41], and on machine learning algorithms to
8 capture short-term fluctuations [42].
9

10 Prosumers' supply temperature and, possibly, flowrate fed in the network must be stable during operation,
11 in order to minimize disturbances and to avoid low cycle fatigue in buried steel pipes of the DHN [43]. This is
12 a critical issue for decentralized SDH plants, since solar energy is variable and non-programmable and hence
13 relevant fluctuations in heat production are frequent, which requires robust control systems [44].
14
15

16 Active substations, i.e. substations that can feed heat in the DHN, are a key component in bidirectional DHNs,
17 because they must properly exchange heat with the network according to the prosumer's demand and
18 production. Moreover, they must deliver heat to the network under precise requisites of temperature and
19 pressure, in order to minimize the generation of disturbances in the network. They can be classified as feed-
20 in substations, i.e. substations that feed excess heat locally generated to the DHN, and prosumers'
21 substations, i.e. substations that are designed for bidirectional heat transfer with the network. As regards
22 the hydraulic connection of substations to the DHN, there are four possible solutions [26]. The return-to-
23 supply configuration is the more complex, since it can lead to issues related to differential pressure and
24 reverse flow in the network [45]. However, this layout does not influence the supply temperature, avoiding
25 contractual issues with the DH operator, and it has been widely analyzed [44], [46].
26
27

28 While different numerical models have been implemented to evaluate the performance of active DHNs
29 systems with prosumers, the design and experimental testing of actual bidirectional substations remain far
30 from exhausted. Ben Hassine and Eicker [27] presented a test rig for decentralized solar heat integration
31 designed for substations up to 50 kW and maximum flowrate of 4 m³/h, and a bidirectional substation based
32 on the feed-in return-to-supply layout. Heymann et al. [47] compared the design, the control strategy and
33 the measurements of two small-scale ST feed-in substations, where one substations had a feed-in set point
34 of 110 °C and an indirect return-to-supply connection to the DHN, while the other was directly return-to-
35 return connected to the DHN with a feed-in set point of 65 °C. As regards control strategies, Rosemann [46]
36 developed a controller to optimize the management of energy produced by solar collectors that switched
37 between feed-in into the DHN and the coverage of the user's load, for a prototype of a bidirectional
38 substation. Lorenzen et al. [10] developed a concept of a smart substation focusing on temperature, flow
39 and pressure sensors, as well as new controllers connected to the control software of the network. Lazarević
40 et al. [48] developed a simulation model of a traditional DH substation focusing on the mixing valve installed
41 in the users' circuit, and implemented a real-time model of a substation in LabVIEW® for the design of
42 efficient control strategies and hardware-in-the-loop tests.
43
44

45 The present paper aims at providing a comprehensive contribution to the design and testing of an actual
46 bidirectional substation for DH, focusing of the hydraulic connections and on the control strategies. The
47 prototype of substation, with a technology readiness level TRL 4, has a return-to-supply configuration and
48 allows a simultaneous two-way heat exchange with the network. The substation was designed by University
49 of Bologna and ENEA aiming at finding the suitable components, sensors and control strategies for an
50 efficient and reliable bidirectional heat exchange with the DHN.
51
52

53 Extensive tests were carried out in order to evaluate the substation dynamic behavior both from an energetic
54 and hydraulic point of view. Tests were performed at EURAC Energy Exchange Lab, which is equipped with a
55 small-scale district heating and cooling network able to reproduce the operation of actual DHNs, in order to
56 simulate low-temperature innovative networks with the integration of multiple distributed heat sources [49].
57
58
59
60
61
62
63
64
65

1 During the first test campaign, dynamic tests were carried out with fictitious profile variations of selected
2 quantities aimed at evaluating the proper operation of the prototype. The data acquisition and monitoring
3 systems were implemented in LabVIEW®, in order to exploit the benefit of a flexible platform and improve
4 the interaction with the test facility.

5 As regards the potential applications, the substation can be connected to a generic generation system, e.g.
6 solar thermal, micro-cogenerator or heat recovery unit. The substation is automatically able to manage
7 multiple heat exchanges to/from the network, depending on the balance between the user's demand and
8 the local heat production.
9

10 The paper is organized as follows: Section 2 outlines the design of the prototype, the control strategies and
11 the type of connection with the DH network; Section 3 describes the test methodology, the setup and the
12 objectives of the test campaign; Section 4 reports the main results and the performance of the substation,
13 while Section 5 summarizes the conclusions and the future developments.
14
15
16
17

18 **2. Prosumer substation design**

19 In order to allow a bidirectional heat exchange between the prosumer and the DHN, four different
20 connections between the substation and the DHN are possible:
21

- 22 1. Supply-to-return: the fluid heated by the decentralized generation system (DG) is extracted from the
23 supply pipe and reintroduced in the return line of the DHN;
- 24 2. Supply-to-supply: connections to feed heat produced by the DG in the DHN are located at the supply
25 pipe;
- 26 3. Return-to-return: connections to feed heat produced by the DG in the DHN are located at the return
27 pipe;
- 28 4. Return-to-supply: the fluid heated by the DG comes from the DHN return pipe and is pumped in the
29 DHN supply pipe.
30
31
32
33

34 The details about the schemes can be found in [50]. Based on the thermo-hydraulic evaluations presented in
35 [26] in particular relating to the temperature levels modifications in the DHN caused by prosumers, the
36 *return-to-supply* configuration has been chosen for the designed substation. In this configuration, the
37 prosumer substation heats the fluid up to the DHN supply temperature without modifying the temperature
38 levels of both the DH supply and the return pipes. This is particularly advantageous both for the downstream
39 users (since a constant temperature is required and, in case of additional prosumers, allows them to feed
40 heat into the DHN) and for the thermal management of the DH central plant.
41
42

43 The detailed scheme of the substation, including the sensors and the main components for safety and
44 control, is depicted in Figure 1. The scheme highlights three hydraulic circuits: the primary circuit connects
45 the substation to the supply (in red) and the return (in blue) pipes of the DHN, the secondary circuit (in green)
46 connects the substation to the user, and the tertiary circuit (in black and grey) connects the substation to the
47 DG system. In order to manage reliably multiple heat exchanges according to the user's heat demand and
48 the DG thermal production, the substation is equipped with three heat exchangers (HE):
49
50

- 51 • HE1 connects the user to the supply and the return pipes of the DHN (i.e. the configuration of
52 traditional DH substations);
- 53 • HE2 connects the user to the DG;
- 54 • HE3 connects the DG to the DHN.
55

56 The design rationale is that the DG thermal production is primarily used to fulfil the user's thermal needs,
57 and then the excess heat produced by the DG feeds the network when it complies with the temperature
58 requirements at the supply side. In detail:
59
60
61
62
63
64
65

- The user's thermal load is satisfied by the DHN and/or by the DG system via HE1 and HE2, respectively. If the DG system fulfils the user's load then HE1 does not work, otherwise it integrates HE2. Without DG heat production, HE2 does not work and the DHN fulfils the total user's load;
- As regards the heat fed into the DHN, if the DG production exceeds the user's need then HE3 feeds the excess of thermal power into the DHN. The prosumer substation feeds heat in the DHN only if the DG can raise the temperature of the fluid taken from the DH return pipe up to the DH supply level. In this case, HE1 is not in operation.

As shown in Figure 1, the substation is equipped with the temperature, pressure and flowrate sensors required for an accurate lab-scale testing. In addition, actuators consist of two and three-way motorized valves manufactured by Siemens, and of a variable speed pump DAB mod. Evoplus 60/180M equipped with a multifunction module. The latter controls and sets the required flowrate to be supplied in the DHN by complying with the required feed-in temperature. The pump is necessary to overcome the pressure difference between the return and the supply pipelines of the DHN.

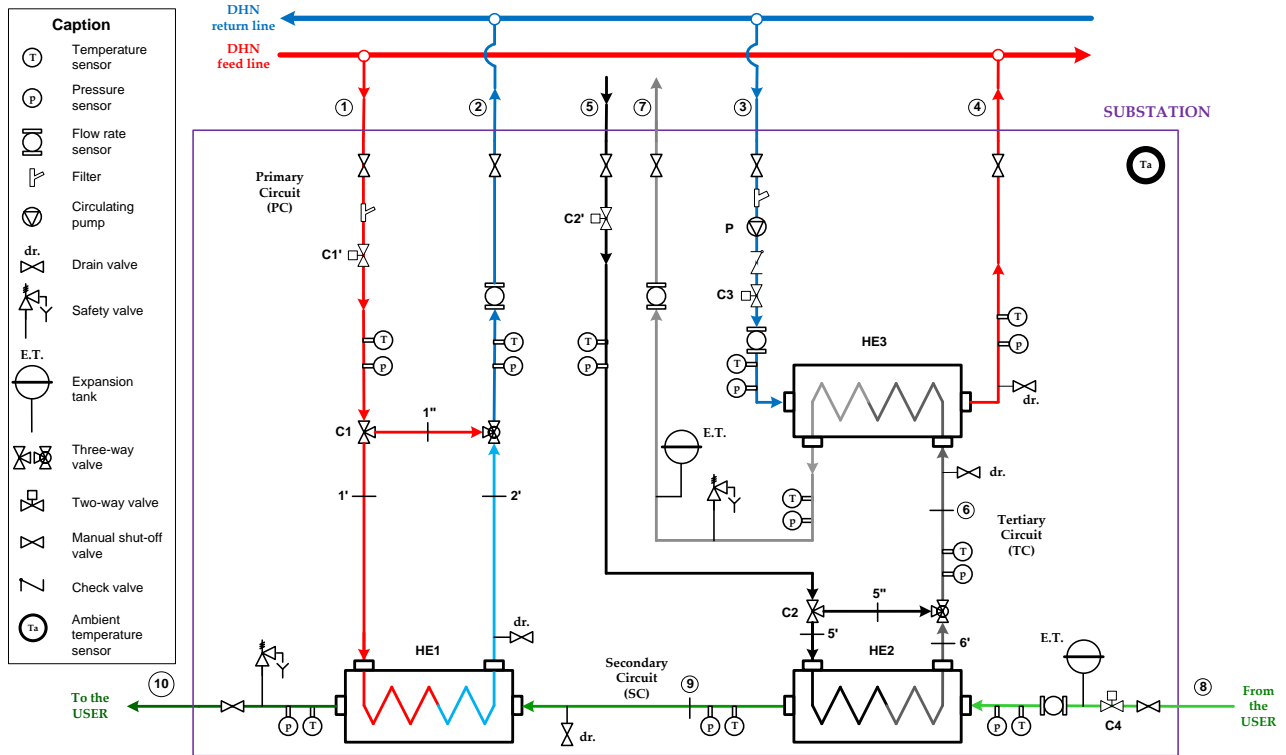

Figure 1. Scheme of the designed prosumer substation.

The heat exchangers have been sized with reference to state-of-the-art DH networks, and assuming supply and return temperatures equal to 80 °C and 50 °C, respectively. Other design values are the heat supply temperatures of the DG system (90 °C), and to the user (60 °C). Table 1 summarizes the design parameters for the three HEs of the substation. As a prototype, the HE sizes account for the lab scale application required for the experimental tests.

The position of the HEs and their connection pipes have been optimized in order to realize a plug&play solution for accurate monitoring during tests. A view of the 3D CAD drawing is presented in Figure 2, while Figure 3 and Figure 4 show pictures of the inside of the substation and its connection with the Energy Exchange Lab through flexible pipes. The substation has been designed and realized for outdoor installation; the external dimensions are 3.15 m length, 1.90 m height, 1.10 m width.

Table 1. Heat exchangers design parameters.

Heat Exchanger HE1			
Primary side		Secondary side	
$F_{1'}$	1.20 m ³ /h	F_9	1.80 m ³ /h
$T_{1'}$	80 °C	T_9	40 °C
$T_{2'}$	50 °C	T_{10}	60 °C
Q		42 kW	
UA		2.90 kW/°C	
Heat Exchanger HE2			
Primary side		Secondary side	
$F_{5'}$	3.60 m ³ /h	F_8	1.80 m ³ /h
$T_{5'}$	90 °C	T_8	40 °C
$T_{6'}$	80 °C	T_9	60 °C
Q		42 kW	
UA		1.20 kW/°C	
Heat Exchanger HE3			
Primary side		Secondary side	
F_3	2.14 m ³ /h	F_6	2.80 m ³ /h
T_3	50 °C	T_6	90 °C
T_4	80 °C	T_7	67 °C
Q		75 kW	
UA		5.59 kW/°C	

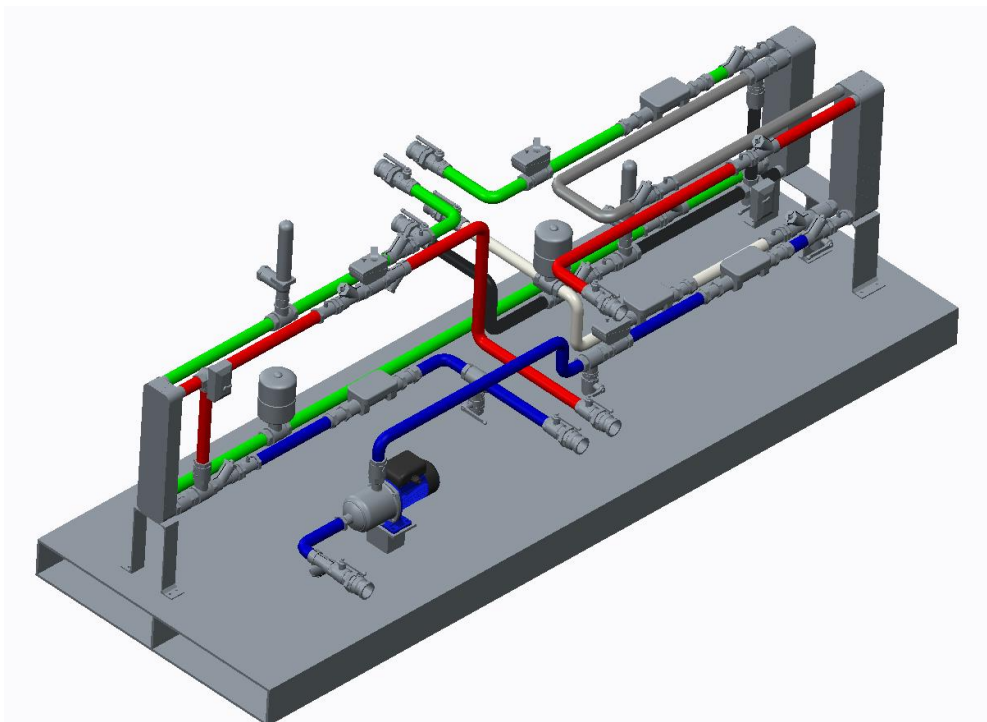

Figure 2. 3D CAD drawing of the prosumer substation.



Figure 3. Inside of the prosumer substation.



Figure 4. Hydraulic connections of the prosumer substation to the Energy Exchange lab.

2.1. Control logic

The substation is equipped with five valves that can be divided in two typologies depending on the operational logic, as it follows (with reference to Figure 1):

- (i) Valves C1', C2' and C4 control the flowrate of the corresponding circuit;
- (ii) Valves C1 and C2 regulate the flowrate at the HE primary side, according to the set point temperature at the outlet of the HE secondary side.

In order to properly manage the bidirectional heat exchange and satisfy the user's needs and the constraints imposed on temperatures and flowrates, a proper control logic of the substation has been designed. It controls the correct operation (valves opening/closure, pump speed, etc.), based on the set points of the control variables. In detail, the nominal values of these variables are listed in Table 2.

Table 2. Substation control variables and nominal values.

Control variables	Nominal value
DG system flowrate (F ₇)	2.8 m ³ /h

Flowrate from the DHN to HE1 (F_2)	1.8 m ³ /h
User flowrate (F_8)	1.8 m ³ /h
Minimum feed-in flowrate in the DHN ($F_{3,min}$)	0.8 m ³ /h
User supply temperature (T_{10})	60 °C
Minimum temperature difference between DG and user ($\Delta T_{5,min}$)	5 °C
Substation supply temperature to the DHN (T_4)	80 °C
Minimum inlet temperature in the primary side of HE3 ($T_{min,DHNfeed}$)	82 °C

Table 3 shows the controlled variable (C) to reach the set point (SP) for each actuator (A). Moreover, the actuator state is bound to some conditions and it could be closed/OFF (in case of valves and pump, respectively) or in action. The control logic described below has been implemented by using Proportional-Integral-Derivative (PID) controllers.

Table 3. Control logic overview with reference to the substation scheme in Figure 1 (A: actuator, C: controlled variable, SP: set point).
When an actuator is in action, a PID controller keeps the system close to the set point.

A	C	SP	Condition	Actuator state
C1'*	F_2	$F_{2,SP}$	$T_9 \geq T_{10,SP}$ or $F_8=0$ $T_9 < T_{10,SP}$	C1'closed C1'action
C1	T_{10}	$T_{10,SP}$		C1 action
C4	F_8	$F_{8,SP}$		C4 action
C2'*	F_7	$F_{7,SP}$	$(T_5 < T_8 + \Delta T_{5,min})$ or $(T_6 < T_{min,DHNfeed}$ and $F_8 = 0)$ $(T_5 \geq T_8 + \Delta T_{5,min}$ and $M_8 > 0)$ or $(T_6 \geq T_{min,DHNfeed}$ and $M_8 = 0)$	C2'closed C2'action
C2	T_9	$T_{10,SP}$		C2 action
P	T_4	$T_{4,SP}$	$T_6 \geq T_{min,DHNfeed}$ $M_7 = 0$ or $T_6 < T_{min,DHNfeed}$	P action P OFF

*During the test campaign a hysteresis was added to $T_{10,SP}$ and $T_{min,DHNfeed}$ in order to avoid the intermittent operation of HE1 and HE3, respectively.

3. Test methodology

3.1. Test set-up

The test campaign was performed at the Energy Exchange Lab of EURAC Research, which is equipped with a small-scale DH network, able to emulate both conventional and low-temperature networks with the integration of multiple heat sources [49]. The campaign was preceded by a set of steady state tests aimed at calibrating the instrumentation and at checking the actual performance of the substation with respect to the design values. The results of the steady state tests confirmed that the substation worked as expected.

The following experimental campaign included eight dynamic tests with different levels of interactions between the three HEs of the substation. In these tests, the user's thermal load and the DG production profiles were dynamically varied according to fictitious profiles. The user thermal load profile was varied by varying the flowrate (F_8) and/or by varying the return temperature (T_8), while the DG production profile was varied by varying the flowrate (F_7). The objective of these tests was to characterize the substation, i.e. evaluate the dynamic response of the controls and the thermal and hydraulic performance of the substation.

In the dynamic tests, some control variables were set to the nominal values (see Table 2) while others were varied, as described in the following. The variables directly controlled by the test facility are summarized in Table 4. Regarding the goodness of the temperature control of the test facility, the maximum difference between the average controlled temperature and the set point was 1.6 °C for each test.

Table 4. Test facility controlled variables and nominal values.

Controlled variable	Nominal value
DHN supply temperature to HE1 (T_1)	80 °C
DG system supply temperature (T_5)	90 °C
Return temperature from DHN (T_3)	50 °C
User return temperature (T_8)	40 °C

Control and data acquisition systems of the substation have been implemented in LabVIEW® and with National Instruments electronics at EURAC, and integrated with the control system of the test facility for an efficient and reliable interaction and data exchange. Sampling rate was set equal to 1 second for all tests.

3.2. Measurement uncertainty

The sensors installed in the substation (Figure 1) have been used to determine the performance of the prototype. The types of sensors, the measurement uncertainty and derived quantities are described as follows.

Temperature sensors – resistance thermometers Siemens model QAE2111.010 - are Pt100 Class B type. The measurement uncertainty (σ_T) of the sensor only can be calculated as:

$$\sigma_T = \pm(0.005 \cdot T + 0.3) [^{\circ}\text{C}]$$

The uncertainty ranges from 0.45 °C to 0.75 °C in the interval of interest (30-90 °C).

The four flow meters – Siemens mod. SITRANS F M MAG 5000/3100P - are based on the electromagnetic induction effect. The relative measurement uncertainty of the fluid speed can be calculated as:

$$\sigma_v/v = (0.4\% v[\text{m/s}] \pm 0.001 \text{ m/s})/v$$

The flowrate range in the tests is 0.8–3.0 m³/h, and the sensors have a diameter of DN25. Therefore, the fluid speed ranges from 0.36 m/s to 1.36 m/s, and the relative uncertainty ranges from 0.68% to 0.47%. These values correspond to the flowrate relative uncertainty in the interval of interest, σ_F/F , by assuming a negligible uncertainty on the pipe diameter.

Pressure sensors – Siemens mod. QBE2103-P4 - are based on the piezo-resistive principle and have a measurement uncertainty of 0.3% of full-scale (4 bars). Therefore, the absolute uncertainty is $\sigma_p = 0.012$ bar. In the case of pressure difference, the uncertainty is equal to 0.017 bar according to:

$$\sigma_{\Delta p} = \sqrt{\sigma_{p_1}^2 + \sigma_{p_2}^2}$$

Temperature difference. It is necessary in order to evaluate the thermal power. In general, with a temperature difference $\Delta T = T_1 - T_2$, the propagated relative uncertainty is:

$$\sigma_{\Delta T} = \sqrt{\sigma_{T_1}^2 + \sigma_{T_2}^2}$$

The typical nominal temperature differences in this application are either 10 °C or 20 °C and the relative uncertainties $\sigma_{\Delta T}/\Delta T$ are in the order of 10% and 4%, respectively.

Thermal power (Q) is calculated as:

$$Q = F \cdot \rho \cdot c_p \cdot \Delta T \quad [\text{kW}]$$

where:

- F is the volumetric flowrate [m³/h];

- ρ is the water density [kg/m³] calculated as:

$$\rho = 10^{-5}T_F^3 - 5.6 \cdot 10^{-3}T_F^2 + 3.7 \cdot 10^{-3}T_F + 1000.3$$

- c_p is the water specific heat [kJ/(kg°C)] calculated as:

$$c_p = -5 \cdot 10^{-11}\overline{T_m}^5 + 2 \cdot 10^{-8}\overline{T_m}^4 - 2 \cdot 10^{-6}\overline{T_m}^3 + 10^{-4}\overline{T_m}^2 - 3.6 \cdot 10^{-3}\overline{T_m} + 4.218$$

- $\overline{T_m}$ is the average temperature corresponding to the calculated thermal power.

The measurement uncertainty of the thermal power is calculated with the following expression:

$$\sigma_Q/Q = \sqrt{(\sigma_{\Delta T}/\Delta T)^2 + (\sigma_F/F)^2}$$

Since the uncertainty of the flow meter is much lower than that of the temperature difference, the latter prevails. The same measurement uncertainty can also be assumed for the thermal energy, $E_{th} = \int Q dt$, due to possible correlations in power errors (e.g. bias errors) [51].

4. Test results

As anticipated, the preliminary steady state tests confirmed the design of the substation in terms of flowrates and temperatures. In order to check the proper operation of the substation, the instantaneous relative deviation was calculated for temperatures and flowrates as (Y refers to a generic variable):

$$\Delta Y_{\%} = \frac{Y_{measured} - Y_{reference}}{Y_{reference}}$$

By averaging deviations over each steady state test duration, the maximum deviation values for temperature and flowrate controls were -0.16% and -0.10%, respectively.

The dynamic tests were carried out with fictitious profile variations of selected quantities in order to characterize the prototype from a thermal and hydraulic point of view. Moreover, they allowed evaluating the proper operation of the control system whose main objectives are to satisfy the user's heat load at 60 °C, and to supply the excess heat at 80 °C from the DG system into the DHN. Among the eight scenarios tested, three tests have been selected and described here as the representative ones. They show how the three HEs interacted and how the substation worked to satisfy the user's needs and the DHN feed-in requirements. In the following, the selected tests are named as "Test 1", "Test 2" and "Test 3". Data showed in the following figures have a sampling rate of one second.

Test 1 provided for the operation of the HE2 (heat from the DG system to the user) and HE3 (heat from DG system to the DHN) for different levels of user thermal loads, which was varied between nominal, maximum and zero values. From a practical point of view, the user load was varied by varying the return temperature (T_8) and the flowrate (F_8) according to the profiles depicted with dotted lines in the top graph of Figure 5. All the other quantities were set to the nominal values. Figure 5 and Figure 6 depict the representative quantities for Test 1, which are plotted only in case the associated HE was in operation, similarly to all the figures that follow. The test duration was seven hours.

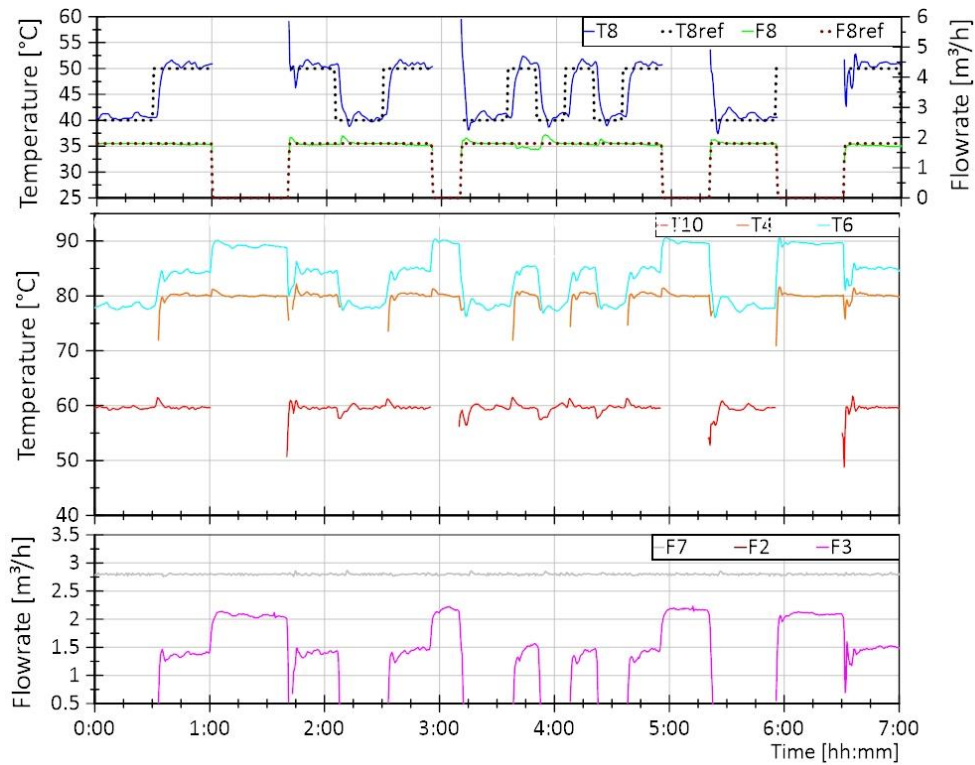

Figure 5. Test 1. Top graph shows the dynamic inputs to the substation as measured variables (T_8 and F_8) and relative reference profiles ($T_{8,ref}$ and $F_{8,ref}$). Middle and bottom graphs show the test representative quantities and the variables directly controlled by the substation to the nominal value ($T_{4,nom} = 80$ °C, $T_{10,nom} = 60$ °C).

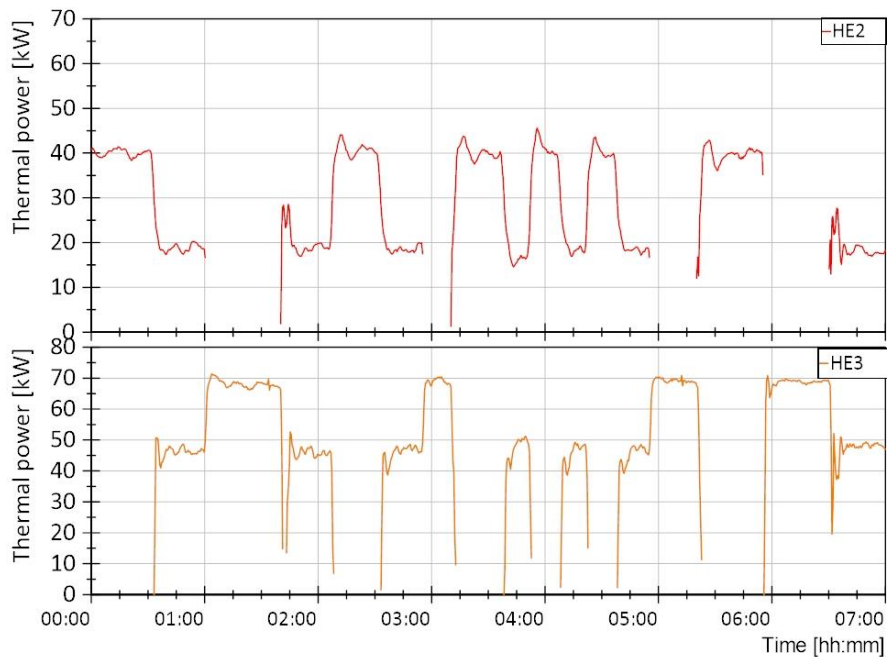

Figure 6. Test 1. User's heat load (red line) and excess heat fed in DHN (orange line).

The graphs in Figure 6 show how HE2 and HE3 interact. When the user's load was around its nominal value (40 kW), it was entirely satisfied by the HE2. In this case, T_6 was too low for the substation to feed heat in the DHN at the required temperature (80 °C) according to the control strategy described in Section 2.1. Therefore, HE3 was not active. If the user load was minimum (20 kW in the present test campaign) or zero, then HE3 was active and could feed the DHN from the DG system. The substation was always able to satisfy the user's heat load at the set point temperature T_{10} (60 °C), even for sudden variation of 10 °C in user's return temperature. Fluctuations of absolute value up to 10 °C for less than 5 minutes when the HE2 restarted

were due to transient effects. The same fluctuations affected the behavior of the DHN feed-in temperature (T_4) when HE3 restarted after a stop. They were due to the typical transient effects occurring when fluid flowed again in the HE after a stop.

Test 2 focused on the operation of HE1 (heat from DHN to the user) and HE2 (heat from DG to the user) for different levels of the user's load, which was varied between the nominal and maximum values. Operatively, the user's load was modified by varying the return temperature (T_8), as shown in the top graph of Figure 7. All the other quantities were set to their nominal values. The representative quantities for Test 2 are shown in Figure 7 and in Figure 8, where they are plotted only if the associated HE was in operation. The test duration was seven hours.

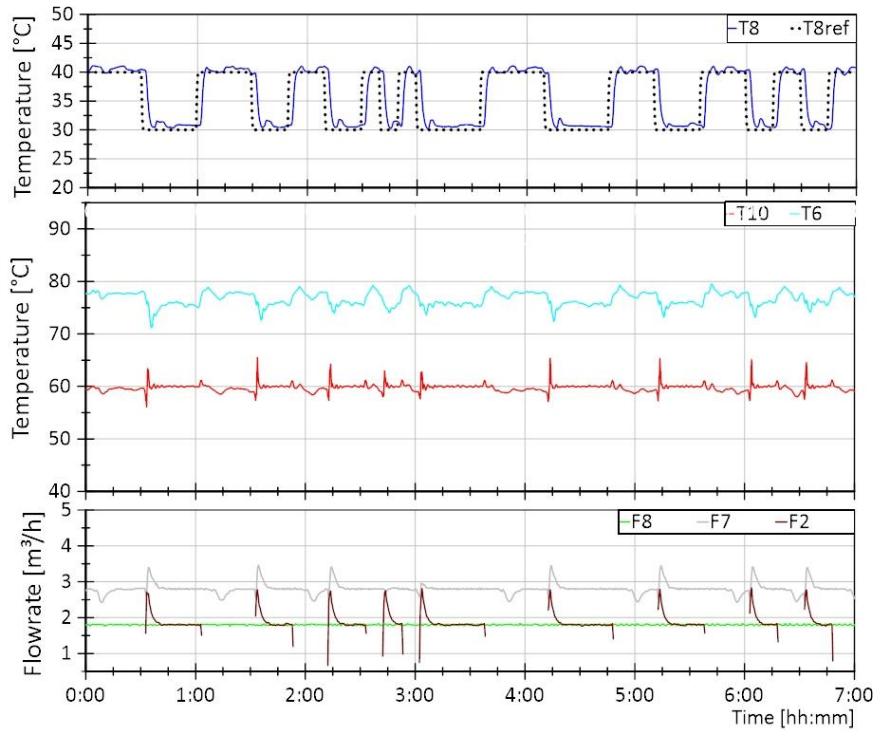

Figure 7. Test 2. Top graph shows the dynamic inputs to the substation as measured variables (T_8) and relative reference profile ($T_{8,ref}$). Middle and bottom graphs show the test representative quantities and the variables directly controlled by the substation to the nominal value ($T_{10,nom} = 60$ °C).

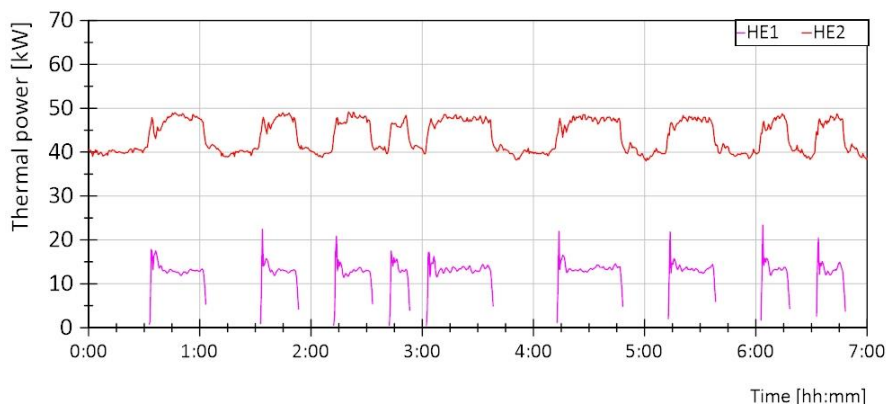

Figure 8. Test 2. User's heat load satisfied by HE1 (violet line) and by HE2 (red line).

The graphs in Figure 8 show how the exchangers HE1 and HE2 interacted in order to satisfy the user's load. When the user's load was at its nominal value (40 kW), it was satisfied by HE2 that was the only HE in operation. As shown in Figure 7, temperature T_6 was not sufficient to activate HE3 since it did not respect the requirement on the DHN feed-in temperature according to the control strategy described in Section 2.1.

When the user's load was maximum (60 kW), the DG had to be integrated by the DHN through HE1. Nevertheless, the substation was always able to supply the user at 60 °C (T_{10}), even for sudden variations of 10 °C in the user's return temperature, and for some fluctuations in the heat supply flowrate occasionally introduced by the test facility. Fluctuations in the user supply temperature (T_{10}) of +/- 5 °C that lasted less than 5 minutes were recorded when the HE1 restarted after a stop. They were due to typical transient effects when the HE restarted.

Test 3 provided for the operation of the HE1 (heat from DHN to the user), HE2 (heat from DG system to the user) and HE3 (heat from DG system to the DHN) for different values of the user's thermal load, which was varied from zero to minimum up to nominal values, and for different levels of the DG heat production. In practice, the user's load was modified by changing the return temperature (T_8) and the flowrate (F_8), while the DG was modified by means of a variable flowrate (F_7), as shown in the top graph of Figure 9. All the other quantities were set to the nominal values. The representative quantities for the test are plotted in Figure 9 and in Figure 10, only in case the associated HE was in operation. The test duration was seven hours.

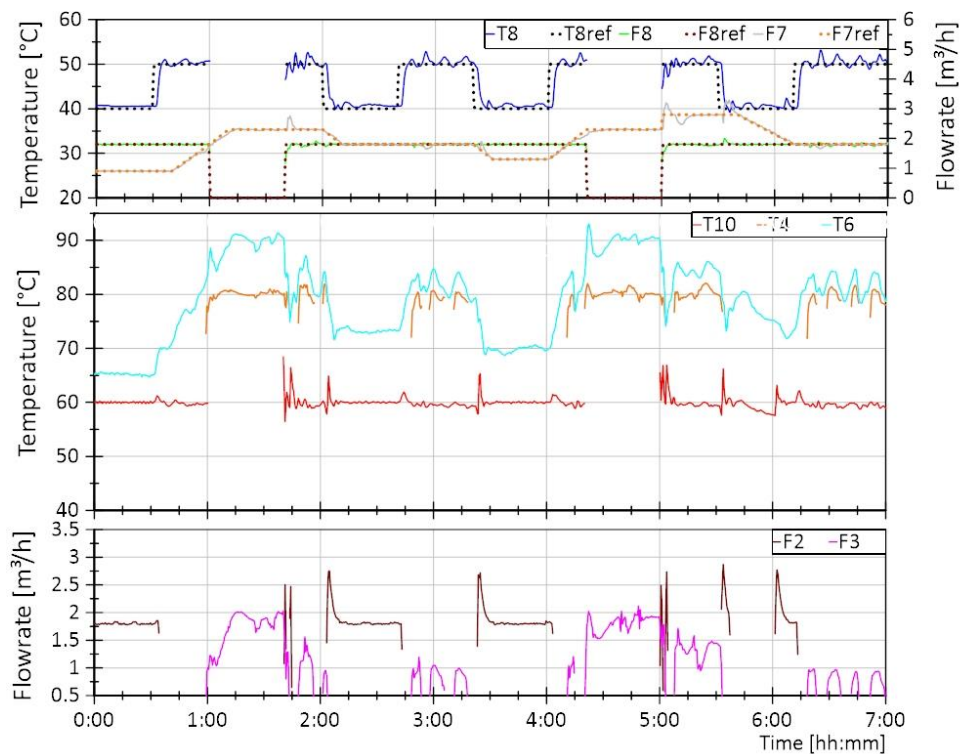

Figure 9. Test 3. Top graph shows the dynamic inputs to the substation as measured variables (T_8 , F_8 and F_7) and relative reference profiles ($T_{8,ref}$, $F_{8,ref}$ and $F_{7,ref}$). Middle and bottom graphs show the test representative quantities and the variables directly controlled by the substation to the nominal value ($T_{4,nom} = 80$ °C, $T_{10,nom} = 60$ °C).

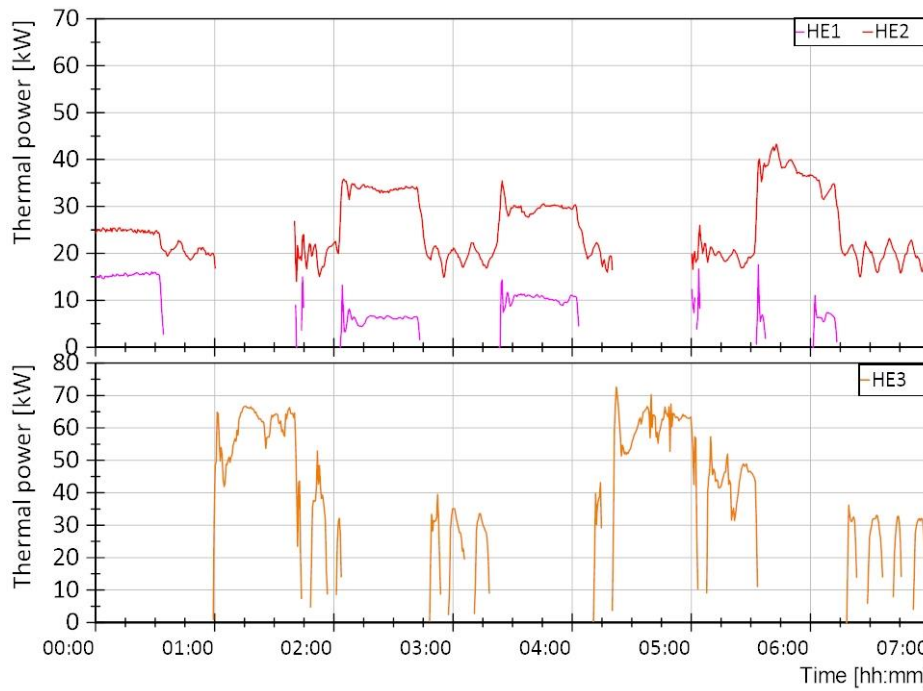

Figure 10. Test 3. User's heat load satisfied by HE1 (violet line) and by HE2 (red line). Excess heat fed into the DHN by HE3 (orange line).

Figure 10 shows how HE1, HE2 and HE3 interacted in order to satisfy the user need and feed the excess heat from the DG in the DHN. When the user's load was at nominal conditions (40 kW), it was not fully satisfied by HE2 since the latter did not operate at nominal conditions, unlike the previous tests. In this case, HE1 integrated HE2, therefore there was no excess heat and hence HE3 was not active. When the user's load was equal to the minimum value (20 kW), it was fully satisfied by the DG system through HE2. In this case, the HE3 was active intermittently and fed the DHN when temperature T_6 was sufficiently high (see Section 2.1). In case the user's load was null, HE3 was active and fed the DHN. The substation was always able to supply the user's load at the required supply temperature ($T_{10} = 60 \text{ }^\circ\text{C}$), even for sudden variations of $10 \text{ }^\circ\text{C}$ in the user's return temperature, and for fluctuations in the heat supply flowrate introduced by the test facility. Fluctuations in the user's supply temperature (T_{10}) of $\pm 5 \text{ }^\circ\text{C}$ that lasted less than 5 minutes were recorded when the HE1 restarted after a stop. Similarly to previous tests, they were due to typical transient effects occurring at the restarting of a HE. The substation fed-in the DHN at $80 \text{ }^\circ\text{C}$ except for some brief fluctuations of $5 \text{ }^\circ\text{C}$ when HE3 was turned on.

Test 3 included the operation of all HEs. Figure 11 highlights the energy balance related to the fulfilment of the user's load (on the left), and to the DG heat production supplied to the user and fed into the DHN (on the right). Regarding the user's load, 87% was satisfied by the DG and 13% by the DHN. Regarding the DG production, 51% of the supplied heat in the prosumer substation covered the user's load while 47% fed the DHN; the remaining 2% were thermal losses.

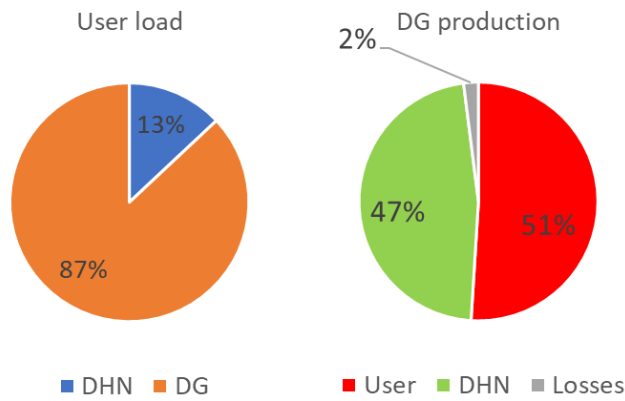

Figure 11. Test 3. Energy balance in the substation.

Figure 12 and Figure 13 summarize the behavior of the substation during the three dynamic tests. Figure 12 shows that the substation control satisfied quite well the requested user's supply temperature, with small variations around the set point (60 °C). When the user's load changed, the substation control followed the variation by supplying heat in the range 55-65 °C, with 70 °C (high) and 50 °C (low) as maximum deviations. Moreover, most of the data were in the range 57 – 62 °C. It is worth pointing out that these results were obtained with a sampling time of 1 second. Actually, variations in the supply temperature of few seconds have negligible effects on the users' perception and on the operation of the heating system and the DHN.

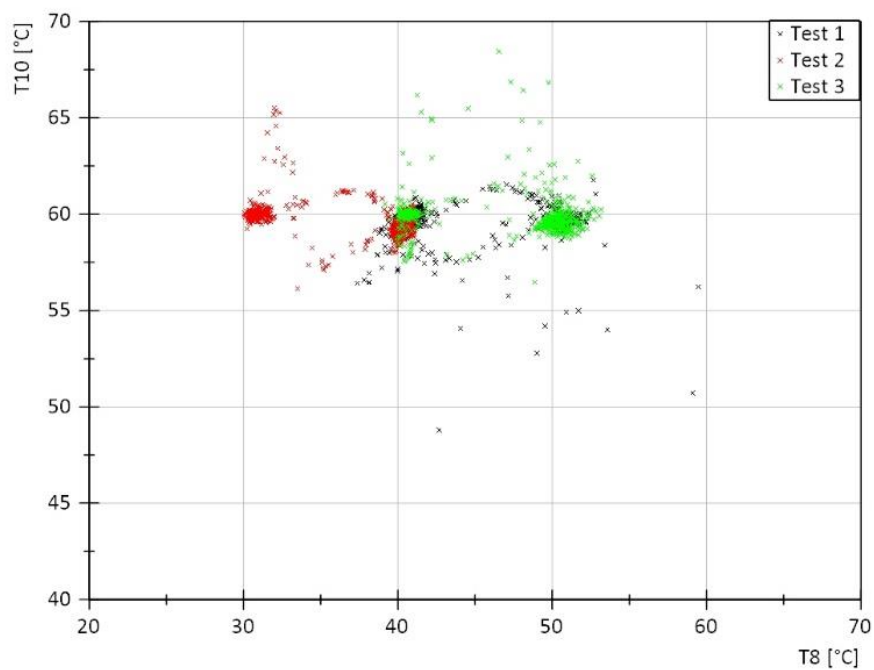

Figure 12. User's supply temperature (T_8) vs return temperature (T_{10}) for Test 1 (black), Test 2 (red) and Test 3 (green).

Figure 13 shows the performance of the prosumer substation to feed the DHN at the prescribed temperature of 80 °C through the excess heat from the DG system. When the availability of excess heat changed, the substation control system followed the dynamics by feeding the DHN with temperature variations limited in the range 78-82 °C, with some outliers recorded at 71 °C. As already mentioned, the sampling time during the tests was 1 second. It is worth pointing out that small variations in DHN feeding temperature of few seconds do not significantly influence DHN temperature in the supply pipe.

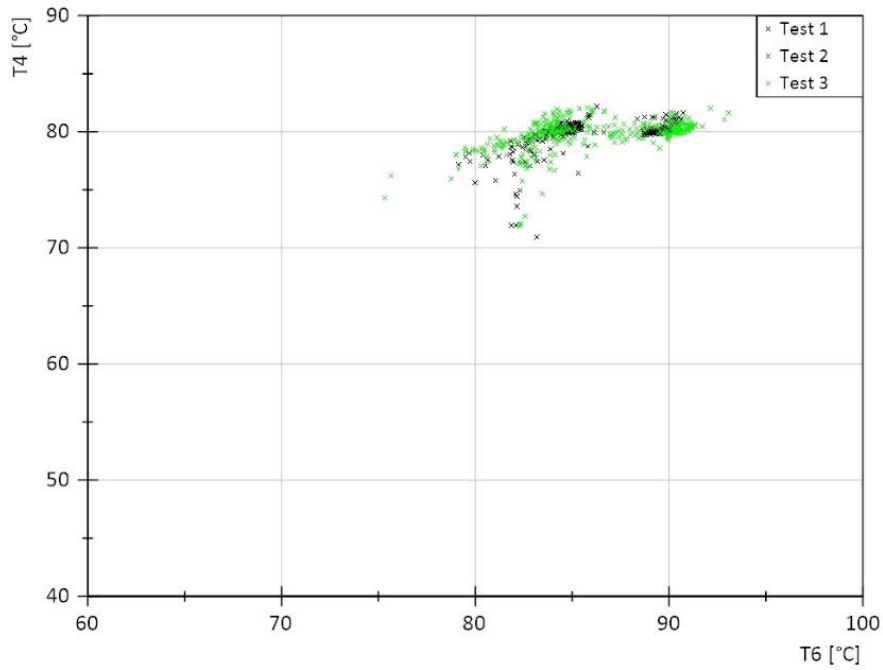

Figure 13. Substation supply temperature to DHN (T_4) vs HE3 inlet temperature (T_6) for Test 1 (black), Test 2 (red) and Test 3 (green).

During the tests, the pressure drop was monitored at the user's side in HE1 and at both sides in HE3. The pressure drop was recorded at both sizes of HE3 since its hydraulic performance is important in order to comply with the feed-in requirements of the substation set by the DH operator. Pressure sensors were installed close to the HE inlets, with no valves or other instruments between the sensor and the HE inlet. As shown in Figure 14, the pressure drop in HE3 was comparable at both sides, while pressure drop in HE1 was higher than in HE3 under the same flowrate, mainly because the latter is bigger. It results that the pressure drops were very low, compared to the typical operative pressures in actual DHNs.

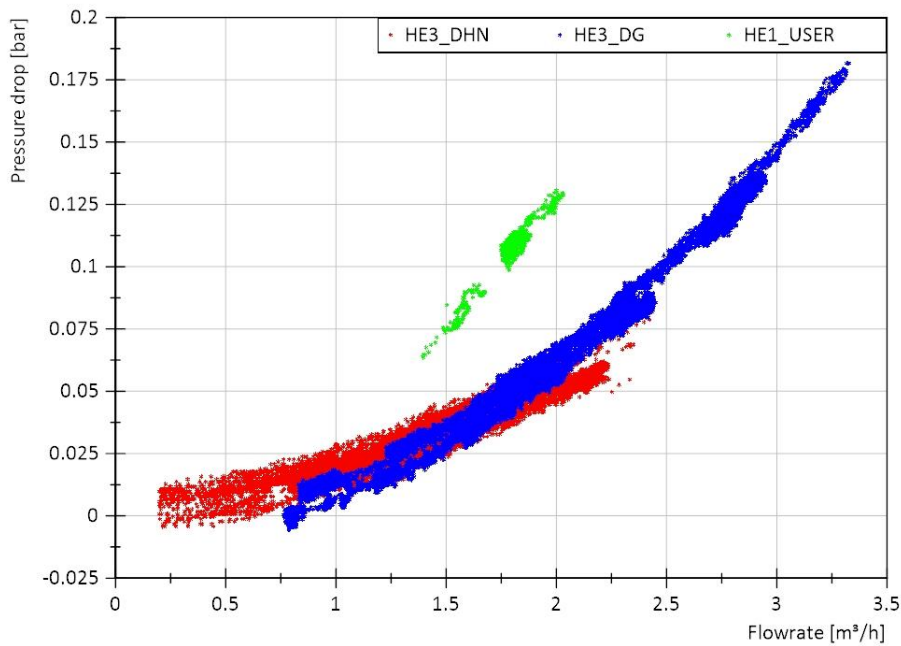

Figure 14. Pressure drop vs flowrate at HE1 user's side (green), at HE3 DG side (blue) and at HE3 DHN side (red).

5. Conclusions

In this paper, the design, realization and testing of a prototype of prosumer substation for active district heating is presented. The substation served primarily to fulfil the prosumer's heat demand, and allowed a simultaneous two-way heat exchange with the network. It has a return-to-supply configuration, and includes three independent heat exchangers for a reliable operation. Heat is supplied to the DHN and to the user at prescribed temperatures, based on the state-of-the-art DHNs and on typical heating systems in the civil sector.

Tests were carried out in a facility able to emulate a DHN with the integration of multiple heat sources. Fictitious profile variations of selected quantities were selected in order to evaluate the proper operation of the substation under dynamic conditions both from an energetic and hydraulic point of view. The data sampling rate was set to 1 second, in order to accurately record the dynamics and the response of the substation. Moreover, a measurement uncertainty analysis was performed on the sensors equipped on the prototype. The tests showed how the heat exchangers of the substation interact, and demonstrated that the substation satisfied the user's needs and the DHN feed-in constraints, according to the prescribed temperature requirements and under different operating conditions. Transient lasted for less than five minutes for substantial temperature (± 10 °C) and flow (from nominal to zero) variations in the distributed generator and in prosumer's heat loads. In particular, during Test 3, 87% of the user heat demand was fulfilled by the DG (only 13% was integrated by the DHN), and 47% and 51% of the DG production were supplied to the DHN and to the user, respectively (2% were heat loss). As regards the hydraulic performance, the pressure drops in the HEs were very low, i.e. below 0.2 bar at max flowrate. The substation was able to manage automatically multiple heat exchanges to/from the network, depending on the balance between the user's demand and the local heat production.

The bidirectional substation is a key element for the development and diffusion of active DH, and more in general for a broader exploitation of renewable energy sources and waste heat recovery in DHNs. In such context, the goal of this project is to realize and demonstrate a reliable and efficient thermal prosumer substation, qualified for utilization in an operational environment.

The next steps of the activity will involve a further test campaign with realistic profiles of the prosumer's heat loads and thermal production of the decentralized DG generator (e.g. solar thermal system since it is widely diffuse in the residential sector) in selected typical days, aiming at assessing the energy balances and the interaction of the substation with the network. Moreover, the control strategy will be tested and optimized under these actual conditions. Finally, an economic analysis will be taken into account. Indeed, while the results presented in this article confirm the technical feasibility of a bidirectional substation, with a modular and easily controllable design, it is also important to clarify its economic feasibility. This will require a joint investigation of investment costs (which can be based on the prototype costs, though they could of course be reduced for final production) and of possible energy exchange scenarios.

Nomenclature

Acronyms

DG	Distributed Generation
DH	District Heating
DHN	District Heating Network
HE	Heat Exchanger
HP	Heat Pump
RES	Renewable Energy Sources
SDH	Solar District Heating
ST	Solar Thermal

Symbols

A	Area [m ²]
F	Volumetric flow rate [m ³ /h]
Q	Thermal power [kW]
T	Temperature [°C]
U	Global heat transfer coefficient [kW/m ² ·°C]
σ	Measurement uncertainty

Acknowledgements

This research was funded by the Italian Electric System Research project, implemented under the 2019-2021 Programme Agreement between the Italian Ministry for the Economic Development and ENEA.

References

- [1] Directive 2012/27/EU of the European Parliament and of the Council of 25 October 2012 on energy efficiency, <https://eur-lex.europa.eu/legal-content/EN/TXT/?uri=celex%3A32012L0027> ; 2012 [accessed 10 June 2020]
- [2] Lund H, Werner S, Wiltshire R, Svendsen S, Thorsen JE, Hvelplund F, Vad Mathiesen B. 4th Generation District Heating (4GDH): Integrating smart thermal grids into future sustainable energy systems. *Energy* 2014;68:1-11. <https://doi.org/10.1016/j.energy.2014.02.089>
- [3] Lund H, Duic N, Østergaard PA, Vad Mathiesen B. Future district heating systems and technologies: On the role of smart energy systems and 4th generation district heating. *Energy* 2018;165:614-619. <https://doi.org/10.1016/j.energy.2018.09.115>
- [4] Ma Z, Knotzer A, Dalmacio Billanes J, Nørregaard Jørgensen B. A literature review of energy flexibility in district heating with a survey of the stakeholders' participation. *Renewable and Sustainable Energy Reviews* 2020;123:109750. <https://doi.org/10.1016/j.rser.2020.109750>
- [5] Schuitema G, Ryan L, Aravena C. The consumer's role in flexible energy systems: an interdisciplinary approach to changing consumers' behavior. *IEEE Power and Energy Magazine* 2017;15:53-60. <https://doi.org/10.1109/MPE.2016.2620658>.
- [6] Buffa S, Cozzini M, D'Antoni M, Baratieri M, Fedrizzi R. 5th generation district heating and cooling systems: A review of existing cases in Europe. *Renewable and Sustainable Energy Reviews* 2019;104:504-522. <https://doi.org/10.1016/j.rser.2018.12.059>
- [7] Hansen M, Hauge B. Prosumers and smart grid technologies in Denmark: developing user competences in smart grid households. *Energy Efficiency* 2017;10:1215-1234. <https://doi.org/10.1007/s12053-017-9514-7>
- [8] Sayegh MA, Danielewicz J, Nannou T, Miniewicz M, Jadwiszczak P, Piekarska K, Jouhara H. Trends of European research and development in district heating technologies. *Renewable and Sustainable Energy Reviews* 2017;68:1183-1192. <https://doi.org/10.1016/j.rser.2016.02.023>
- [9] Dominković DF, Wahlroos M, Syri S, Schrøder Pedersen A. Influence of different technologies on dynamic pricing in district heating systems: Comparative case studies. *Energy* 2018;153:136-148. <https://doi.org/10.1016/j.energy.2018.04.028>
- [10] Lorenzen P, Janßen P, Winkel M, Klose D, Kernstock P, Schrage J, Schubert F. Design of a Smart Thermal Grid in the Wilhelmsburg district of Hamburg: Challenges and approaches. *Energy Procedia* 2018;149:499-508. <https://doi.org/10.1016/j.egypro.2018.08.214>
- [11] Juntunen JK, Hyysalo S. Renewable micro-generation of heat and electricity - Review on common and missing socio-technical configurations. *Renewable and Sustainable Energy Reviews* 2015;49:857-870. <https://doi.org/10.1016/j.rser.2015.04.040>
- [12] Schweiger G, Larsson PO, Magnusson F, Lauenburg P, Velut S. District heating and cooling systems – Framework for Modelica-based simulation and dynamic optimization. *Energy* 2017;137:566-578. <https://doi.org/10.1016/j.energy.2017.05.115>

- 1 [13] Brange L, Englund J, Lauenburg P. Prosumers in district heating networks – A Swedish case study.
2 Applied Energy 2016;164:492-500. <http://dx.doi.org/10.1016/j.apenergy.2015.12.020>
- 3 [14] Di Pietra B, Zanghirella F, Puglisi G. An evaluation of distributed solar thermal net metering in small-
4 scale district heating systems. *Energy Procedia* 2015;78:1859-1864.
5 <https://doi.org/10.1016/j.egypro.2015.11.335>
- 6 [15] Kauko H, Kvalsvik KH, Rohde D, Nord N, Utne Å. Dynamic modeling of local district heating grids with
7 prosumers: A case study for Norway. *Energy* 2018;151:261-271.
8 <https://doi.org/10.1016/j.energy.2018.03.033>
- 9 [16] Huang P, Copertaro B, Zhang X, Shen J, Löfgren I, Rönnelid M, Fahlen J, Andersson D, Svanfeldt M. A
10 review of data centers as prosumers in district energy systems: Renewable energy integration and
11 waste heat reuse for district heating. *Applied Energy* 2020;258:114109.
12 <https://doi.org/10.1016/j.apenergy.2019.114109>
- 13 [17] Wahlroos M, Pärssinen M, Manner J, Syri S. Utilizing data center waste heat in district heating –
14 Impacts on energy efficiency and prospects for low-temperature district heating networks. *Energy*
15 2017;140:1228-1238. <https://doi.org/10.1016/j.energy.2017.08.078>
- 16 [18] Delgado BM, Kotireddy R, Cao S, Hasan A, Hoes PJ, Hensen J, Sirén K. Lifecycle cost and CO₂ emissions
17 of residential heat and electricity prosumers in Finland and the Netherlands. *Energy Conversion and*
18 *Management* 2018;160:494-508. <https://doi.org/10.1016/j.enconman.2018.01.069>
- 19 [19] Solar District Heating. Solar district heating plant database, [https://www.solar-district-](https://www.solar-district-heating.eu/en/plant-database/)
20 [heating.eu/en/plant-database/](https://www.solar-district-heating.eu/en/plant-database/) ; 2020 [accessed 12 June 2020].
- 21 [20] Wang D, Orehounig K, Carmeliet J. Investigating the potential for district heating networks with locally
22 integrated solar thermal energy supply. *Energy Procedia* 2017;122:1057-1062.
23 <https://doi.org/10.1016/j.egypro.2017.07.432>
- 24 [21] Zanghirella F, Canonaco J, Puglisi G, Di Pietra B. Introducing solar thermal “Net metering” in an actual
25 small-scale district heating system: a case-study analysis. *Energy Procedia* 2016;101:240-248.
26 <https://doi.org/10.1016/j.egypro.2016.11.031>
- 27 [22] O’ Donovan K, Falay B, Leusbrock I. Renewables, storage, intelligent control: how to address
28 complexity and dynamics in smart district heating systems? *Energy Procedia* 2018;149:529-538.
29 <https://doi.org/10.1016/j.egypro.2018.08.217>
- 30 [23] Monsalvete Álvarez de Uribarri P, Eicker U, Robinson D. Energy performance of decentralized solar
31 thermal feed-in to district heating networks. *Energy Procedia* 2017;116:285-296.
32 <https://doi.org/10.1016/j.egypro.2017.05.075>
- 33 [24] García NP, Zubi G, Pasaoglu G, Dufo-López R. Photovoltaic thermal hybrid solar collector and district
34 heating configurations for a Central European multi-family house. *Energy Conversion and*
35 *Management* 2017;148:915-924. <https://doi.org/10.1016/j.enconman.2017.05.065>
- 36 [25] Postnikov I, Stennikov V, Penkovskii A. Prosumer in the district heating systems: operating and
37 reliability modeling. *Energy Procedia* 2019;158:2530-2535.
38 <https://doi.org/10.1016/j.egypro.2019.01.411>
- 39 [26] Ancona MA, Branchini L, De Pascale A, Melino F. Smart district heating: Distributed generation
40 systems’ effects on the network. *Energy Procedia* 2015;75:1208-1213.
41 <https://doi.org/10.1016/j.egypro.2015.07.157>
- 42 [27] Ben Hassine I, Eicker U. Control aspects of decentralized solar thermal integration into district heating
43 networks. *Energy Procedia* 2014;48:1055-1064. <https://doi.org/10.1016/j.egypro.2014.02.120>
- 44 [28] Guelpa E, Marincioni L, Verda V. Towards 4th generation district heating: Prediction of building
45 thermal load for optimal management. *Energy* 2019;171:510-522.
46 <https://doi.org/10.1016/j.energy.2019.01.056>
- 47 [29] Guelpa E, Barbero G, Sciacovelli A, Verda V. Peak-shaving in district heating systems through optimal
48 management of the thermal request of buildings. *Energy* 2017;137:706-714.
49 <https://doi.org/10.1016/j.energy.2017.06.107>
- 50
51
52
53
54
55
56
57
58
59
60
61
62
63
64
65

- 1 [30] Geysen D, De Somer O, Johansson C, Brage J, Vanhoudt D. Operational thermal load forecasting in
2 district heating networks using machine learning and expert advice. Energy and Buildings
3 2018;162:144-153. <https://doi.org/10.1016/j.enbuild.2017.12.042>
- 4 [31] Guelpa E, Marincioni L, Capone M, Deputato S, Verda V. Thermal load prediction in district heating
5 systems. Energy 2019;176:693-703. <https://doi.org/10.1016/j.energy.2019.04.021>
- 6 [32] Mazhar AR, Liu S, Shukla A. A state of art review on the district heating systems. Renewable and
7 Sustainable Energy Reviews 2018;96:420-439. <https://doi.org/10.1016/j.rser.2018.08.005>
- 8 [33] Carpaneto E, Lazzeroni P, Repetto M. Optimal integration of solar energy in a district heating network.
9 Renewable Energy 2015;75:714–721. <https://doi.org/10.1016/j.renene.2014.10.055>.
- 10 [34] Wang H, Wang H, Zhou H, Zhu T. Modeling and optimization for hydraulic performance design in multi-
11 source district heating with fluctuating renewables. Energy Conversion and Management
12 2018;156:113-129. <https://doi.org/10.1016/j.enconman.2017.10.078>
- 13 [35] Van Oevelen T, Vanhoudt D, Salenbien R. Evaluation of the return temperature reduction potential of
14 optimized substation control. Energy Procedia 2018;149:206-215.
15 <https://doi.org/10.1016/j.egypro.2018.08.185>
- 16 [36] Volkova A, Krupenski I, Ledvanov A, Hlebnikov A, Lepiksaar K, Latšov E, Mašatin V. Energy cascade
17 connection of a low-temperature district heating network to the return line of a high-temperature
18 district heating network. Energy 2020;198:117304. <https://doi.org/10.1016/j.energy.2020.117304>
- 19 [37] Arabkoohsar A. Non-uniform temperature district heating system with decentralized heat pumps and
20 standalone storage tanks. Energy 2019;170:931-941. <https://doi.org/10.1016/j.energy.2018.12.209>
- 21 [38] Paulus C, Papillon P. Substations for decentralized solar district heating: Design, performance and
22 energy cost. Energy Procedia 2014;48:1076-1085. <https://doi.org/10.1016/j.egypro.2014.02.122>
- 23 [39] Bünning F, Wetter M, Fuchs M, Müller D. Bidirectional low temperature district energy systems with
24 agent-based control: Performance comparison and operation optimization. Applied Energy
25 2018;209:502-515. <https://doi.org/10.1016/j.apenergy.2017.10.072>
- 26 [40] Sommer T, Sulzer M, Wetter M, Sotnikov A, Mennel S, Stettler C. The reservoir network: A new
27 network topology for district heating and cooling. Energy 2020;199:117418.
28 <https://doi.org/10.1016/j.energy.2020.117418>
- 29 [41] Saletti C, Gambarotta A, Morini M. Development, analysis and application of a predictive controller to
30 a small-scale district heating system. Applied Thermal Engineering 2020;165:114558.
31 <https://doi.org/10.1016/j.applthermaleng.2019.114558>
- 32 [42] Saloux E, Candanedo JA. Forecasting district heating demand using machine learning algorithms.
33 Energy Procedia 2018;149:59-68. <https://doi.org/10.1016/j.egypro.2018.08.169>
- 34 [43] Brand L, Calvén A, Englund J, Landersjö H, Lauenburg P. Smart district heating networks – A simulation
35 study of prosumers' impact on technical parameters in distribution networks. Applied Energy
36 2014;129:39-48. <http://dx.doi.org/10.1016/j.apenergy.2014.04.079>
- 37 [44] Lennermo G, Lauenburg P, Werner S. Control of decentralised solar district heating. Solar Energy
38 2019;179:307-315. <https://doi.org/10.1016/j.solener.2018.12.080>
- 39 [45] Heymann M, Rühling K, Felsmann C. Integration of solar thermal systems into district heating – DH
40 system simulation. Energy Procedia 2017;116:394-402. <https://doi.org/10.1016/j.egypro.2017.05.086>
- 41 [46] Rosemann T, Löser J, Rühling K. A new DH control algorithm for a combined supply and feed-in
42 substation and testing through hardware-in-the-loop. Energy Procedia 2017;116:416-425.
43 <https://doi.org/10.1016/j.egypro.2017.05.089>
- 44 [47] Heymann M, Rosemann T, Rühling K, Tietze T, Hafner B. Concept and measurement results of two
45 decentralized solar thermal feed-in substations. Energy Procedia 2018;149:363-372.
46 <https://doi.org/10.1016/j.egypro.2018.08.200>
- 47 [48] Lazarević S, Čongradac V, Anđelković AS, Čapko D, Kanović Z. A novel approach to real-time modelling
48 of the district heating substation system using LabVIEW. Journal of Cleaner Production 2019;2017:360-
49 370. <https://doi.org/10.1016/j.jclepro.2019.01.279>
- 50
51
52
53
54
55
56
57
58
59
60
61
62
63
64
65

- 1 [49] Eurac Research. Energy Exchange Lab,
2 <http://www.eurac.edu/en/research/technologies/renewableenergy/Infrastructure/Pages/Energy-Exchange-Lab.aspx> ; 2020 [accessed 18 June 2020]
3
4 [50] Ancona MA, Branchini L, Di Pietra B, Melino F, Puglisi G, Zanghirella F. Utilities substations in smart
5 district heating networks. *Energy Procedia* 2015;81:597-605.
6 <https://doi.org/10.1016/j.egypro.2015.12.044>
7
8 [51] JCGM 100:2008. Evaluation of measurement data - Guide to the expression of uncertainty in
9 measurement.

10
11
12
13
14
15
16
17
18
19
20
21
22
23
24
25
26
27
28
29
30
31
32
33
34
35
36
37
38
39
40
41
42
43
44
45
46
47
48
49
50
51
52
53
54
55
56
57
58
59
60
61
62
63
64
65

Declaration of interests

The authors declare that they have no known competing financial interests or personal relationships that could have appeared to influence the work reported in this paper.

The authors declare the following financial interests/personal relationships which may be considered as potential competing interests:

Experimental characterization of a prototype of bidirectional substation for district heating with thermal prosumers

Mauro Pipiciello^a, Matteo Caldera^{b,*}, Marco Cozzini^a, Maria A. Ancona^c, Francesco Melino^c, Biagio Di Pietra^b

^a Institute for Renewable Energy, EURAC Research, Viale Druso 1, Bolzano 39100, Italy

^b Energy Efficiency Unit Department, ENEA, Via Anguillarese 301, Rome 00123, Italy

^c Alma Mater Studiorum, Università di Bologna - DIN, Viale del Risorgimento 2, Bologna 40136, Italy

Background

The prosumer, already widespread in the electrical sector, is still uncommon in the district heating (DH) sector. Nevertheless, this figure can potentially provide a relevant contribution to increase the renewable fraction of heat and to decrease the fossil fuel consumption, hence enhancing sustainable and efficient district heating. Moreover, prosumers are more informed and responsible towards energy production and energy savings. In order to enable the two-way heat exchange, the thermal substation at the interface between the prosumer and the DH network must be properly upgraded.

Objective of the paper

The present paper aims at providing a comprehensive contribution to the design and testing of an actual bidirectional substation for district heating with thermal prosumers, focusing on the hydraulic configuration and on the control strategies.

Brief description

The realized substation primarily fulfils the prosumer's heat demand and supplies the excess heat to the DH network only if it is available at the temperature contractually defined with the DH operator, while it uses the network as a source if the local production is not sufficient to cover the user's heat demand. The bidirectional substation can be connected to a generic micro-generation system, e.g. solar thermal or heat recovery units. The prototype, with a technology readiness level TRL 4, allows a simultaneous two-way heat exchange with the network. An extensive test campaign has been carried out in order to evaluate its dynamic behavior both from energetic and hydraulic points of view.

Keywords

District heating

Thermal prosumers

Bidirectional substation

Feed-in substation

Solar district heating

HIGHLIGHTS

- A prosumer, bidirectional substation for district heating has been designed and realized.
- The substation can manage multiple heat exchanges with the user and the DH network.
- Dynamic tests have been carried out in an experimental test facility.
- The bidirectional substation can be connected to generic micro-generation systems.