

Alma Mater Studiorum Università di Bologna
Archivio istituzionale della ricerca

Technologies for the management of MSW incineration ashes from gas cleaning: New perspectives on recovery of secondary raw materials and circular economy

This is the final peer-reviewed author's accepted manuscript (postprint) of the following publication:

Published Version:

Technologies for the management of MSW incineration ashes from gas cleaning: New perspectives on recovery of secondary raw materials and circular economy / Quina, Margarida J.*; Bontempi, Elza; Bogush, Anna; Schlumberger, Stefan; Weibel, Gisela; Braga, Roberto; Funari, Valerio; Hyks, Jiri; Rasmussen, Erik; Lederer, Jakob. - In: SCIENCE OF THE TOTAL ENVIRONMENT. - ISSN 0048-9697. - STAMPA. - 635:(2018), pp. 526-542. [10.1016/j.scitotenv.2018.04.150]

Availability:

This version is available at: <https://hdl.handle.net/11585/634395> since: 2021-12-03

Published:

DOI: <http://doi.org/10.1016/j.scitotenv.2018.04.150>

Terms of use:

Some rights reserved. The terms and conditions for the reuse of this version of the manuscript are specified in the publishing policy. For all terms of use and more information see the publisher's website.

This item was downloaded from IRIS Università di Bologna (<https://cris.unibo.it/>).
When citing, please refer to the published version.

(Article begins on next page)

This is the final peer-reviewed accepted manuscript of

Quina, Margarida J.; Bontempi, Elza; Bogush, Anna; Schlumberger, Stefan; Weibel, Gisela; Braga, Roberto; Funari, Valerio; Hyks, Jiri; Rasmussen, Erik; Lederer, Jakob: Technologies for the management of MSW incineration ashes from gas cleaning: New perspectives on recovery of secondary raw materials and circular economy. SCIENCE OF THE TOTAL ENVIRONMENT 635. ISSN 0048-9697

DOI: 10.1016/j.scitotenv.2018.04.150

The final published version is available online at:

<http://dx.doi.org/10.1016/j.scitotenv.2018.04.150>

Rights / License:The terms and conditions for the reuse of this version of the manuscript are specified in the publishing policy. For all terms of use and more information see the publisher's website.

This item was downloaded from IRIS Università di Bologna (<https://cris.unibo.it/>)

When citing, please refer to the published version.

Technologies for the management of MSW incineration ashes from gas cleaning: New perspectives on recovery of secondary raw materials and circular economy

Margarida J. Quina ^{a,*}, Elza Bontempi ^b, Anna Bogush ^c, Stefan Schlumberger ^d, Gisela Weibel ^d, Roberto Braga ^e, Valerio Funari ^e, Jiri Hyks ^f, Erik Rasmussen ^g, Jakob Lederer ^h

^a CIEPQPF - Research Centre on Chemical Processes Engineering and Forest Products, Department of Chemical Engineering, University of Coimbra, Rua Silvio Lima, Polo II, 3030-790 Coimbra, Portugal

^b INSTM and Chemistry for Technologies Laboratory, University of Brescia, 25123 Brescia, Italy

^c Centre for Resource Efficiency & the Environment (CREE), Department of Civil, Environmental & Geomatic Engineering (CEGE), University College London (UCL), Chadwick Building, Gower Street, London WC1E 6BT, UK

^d Development Center for Sustainable Management of Recyclable Waste and Resources (ZAR), Wildbachstrasse 2, 8340 Hinwil, Switzerland

^e Dipartimento di Scienze Biologiche, Geologiche e Ambientali, Università di Bologna, Piazza di Porta San Donato 1, 40126 Bologna, Italy

^f Danish Waste Solutions ApS, Agern Allé 3, DK-2970 Hørsholm, Denmark

^g Stena Recycling AS, Banemarksvej 40, DK-2605 Brøndby, Denmark

^h TU Wien, Christian-Doppler-Laboratory for Anthropogenic Resources, Karlsplatz 13/226, 1040 Vienna, Austria

HIGHLIGHTS

- Overview of the technologies for the management of APCr/FA from incineration is given.
- Six routes for resource recovery to substitute raw materials or products were detailed.
- The main resource recovered were minerals for building industry, metals, and deicing salts.
- Waste, incineration and APC technologies determine resource contents in APCr/FA.
- Natural resource evaluation can be used to assess resource recovery options of APCr/FA.

GRAPHICAL ABSTRACT

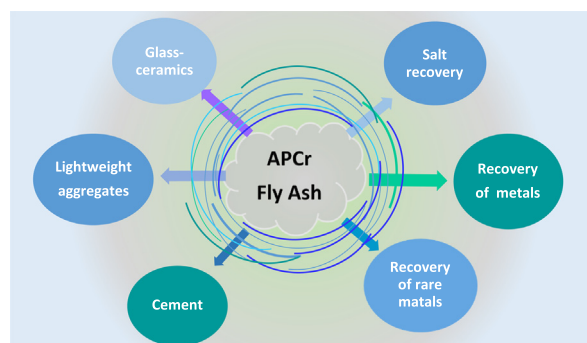

ABSTRACT

Environmental policies in the European Union focus on the prevention of hazardous waste and aim to mitigate its impact on human health and ecosystems. However, progress is promoting a shift in perspective from environmental impacts to resource recovery. Municipal solid waste incineration (MSWI) has been increasing in developed countries, thus the amount of air pollution control residues (APCr) and fly ashes (FA) have followed the same upward trend. APCr from MSWI is classified as hazardous waste in the List of Waste (LoW) and as an absolute entry (19 01 07*), but FA may be classified as a mirror entry (19 01 3*/19 01 14). These properties arise mainly from their content in soluble salts, potentially toxic metals, trace organic pollutants and high pH in contact with water. Since these residues have been mostly disposed of in underground and landfills, other possibilities

* Corresponding author.

E-mail addresses: guida@eq.uc.pt (M.J. Quina), elza.bontempi@unibs.it (E. Bontempi), a.bogush@ucl.ac.uk (A. Bogush), stefan.schlumberger@kebag.ch (S. Schlumberger), gisela.weibel@zar-ch.ch (G. Weibel), r.braga@unibo.it (R. Braga), valerio.funari@unibo.it (V. Funari), jhy@danws.dk (J. Hyks), erik.rasmussen@stenarecycling.com (E. Rasmussen), jakob.lederer@tuwien.ac.at (J. Lederer).

Keywords:
Municipal solid waste
Incineration
Fly ash
Air pollution control residues
Recovery
Toxic metals

must be investigated to recover secondary raw materials and products. According to the literature, four additional routes of recovery have been found: detoxification (e.g. washing), product manufacturing (e.g. ceramic products and cement), practical applications (e.g. CO₂ sequestration) and recovery of materials (e.g. Zn and salts). This work aims to identify the best available technologies for material recovery in order to avoid landfill solutions. Within this scope, six case studies are presented and discussed: recycling in lightweight aggregates, glass ceramics, cement, recovery of zinc, rare metals and salts. Finally, future perspectives are provided to advance understanding of this anthropogenic waste as a source of resources, yet tied to safeguards for the environment.

Contents

1.	Introduction	527
2.	Global perspective	528
3.	Case studies	529
3.1.	Lightweight aggregates	529
3.2.	Glass ceramics	529
3.3.	Cement	531
3.4.	Recovery of Zn, Cu, Cd, Pb	532
3.5.	Recovery of rare earth elements and other rare metals	533
3.6.	Salt recovery	535
3.7.	Summary	536
4.	Future perspectives of APCr/FA as an anthropogenic resource for secondary raw materials	536
4.1.	Geological knowledge (x axis)	537
4.2.	Project feasibility (y axis)	538
4.3.	Socio economic viability (z axis)	538
4.4.	Information requirements for the evaluation of APCr/FA as anthropogenic resource	538
5.	Conclusions	539
	Acknowledgments	539
	References	539

1. Introduction

Municipal solid waste (MSW) management includes collection, treatment, disposal and material recovery activities and it is becoming progressively more complex. Recently the European Commission approved an initiative in favor of fostering a circular economy, which will entail a revision of legislation on waste with clear guidelines. Namely, instruments to promote more recycling and discourage landfilling are expected. In practice, innovative solutions have been proposed with regard to the use of waste as resources. Although hazardous waste is of particular concern, creative ways of recovering materials should be considered even in this case instead of exclusive reliance on treatment and landfilling. Of course, the impact on health and environment must be carefully evaluated to avoid reintroducing pollutants into the material cycle. It is important to note that whenever a waste is classified as hazardous, specific obligations are triggered, not only in terms

of labelling and packaging but also with respect to treatment compliance (European Commission, 2015). The Waste Framework Directive 2008/98/EC (hereinafter WFD) established that a waste must be classified as “hazardous waste” if it has at least one of the hazardous proper ties listed in Annex III (replaced by Regulation N° 1357/2014) and is summarized in Table 1. In addition, it must not exceed the limit values for any of the Persistent Organic Pollutants (POPs) that are defined in Article 7(4) (a) of Regulation (EC) 850/2004 on persistent organic pollutants.

Currently, the classification of waste in the European Union (EU) countries is mainly based on the List of Waste, LoW (Commission Decision 2014/955/EU), and there are now wastes in the category “mirror entry” that can be either hazardous or non hazardous depending on the type and concentration of pollutants it contains. The differentiation in those mirror entry pairs depends on the hazardous properties HP1 to HP15 listed in Table 1. The assignment of codes may have a major impact on the transport, installation permits and decisions concerning the recyclability of waste. In municipal solid waste incineration (MSWI) the wastes formed in gas cleaning units may be categorized with the codes indicated in Table 2. Thus, in the case of wastes categorized as 19 01 05*, 19 01 06*, 19 01 07* and 19 01 10*, the classification designates them as absolute hazardous. However, for “fly ash” and “boiler ash” waste, the classification is a mirror entry pair, and thus further evaluation is possible to classify them as hazardous or non hazardous. In a recent study (BIO by Deloitte, 2015), the impact of different classification approaches for hazard property “HP 14” was assessed for fly ash from incinerators (19 01 13*/19 01 14), and it emphasized the limited recovery options of MSWI fly ash in Europe.

Due to their classification as hazardous waste, earlier attempts at dealing with APCr/FA mainly focused on pre treatment or stabilization in order to reduce the leaching of potentially toxic substances from APCr/FA (Quina et al., 2008b; Hennebert et al., 2014). However, since

Table 1
Properties of waste that render it hazardous (according to Annex III of WFD).

Code	Hazardous property	Code	Hazardous property
HP1	Explosive	HP9	Infectious
HP2	Oxidizing	HP10	Toxic for reproduction
HP3	Flammable	HP11	Mutagenic
HP4	Irritant – skin irritation and eye damage	HP12	Release of an acute toxic gas
HP5	Specific target organ toxicity (STOT)/Aspiration toxicity	HP13	Sensitizing
HP6	Acute toxicity	HP14	Ecotoxic
HP7	Carcinogenic	HP15	Waste capable of exhibiting a hazardous property listed above not directly displayed by the original waste
HP8	Corrosive		

Table 2
Possible entries in LoW related to waste formed and collected during gas cleaning in MSWI.

19 01	Wastes from incineration or pyrolysis of waste	Entry
19 01 05*	Filter cake from gas treatment	AH
19 01 06*	Aqueous liquid wastes from gas treatment and other aqueous liquid wastes	AH
19 01 07*	Solid wastes from gas treatment ^{a)}	AH
19 01 10*	Spent activated carbon from flue-gas treatment	AH
19 01 13*	Fly ash containing hazardous substances	MH
19 01 14	Fly ash other than those mentioned in 19 01 13	MNH
19 01 15*	Boiler dust containing hazardous substances	MH
19 01 16	Boiler dust other than those mentioned in 19 01 15	MNH

Entries marked with an asterisk (*) are considered hazardous waste; a) - Often referred to as air pollution control residues (APCr); AH - absolute hazardous; ANH - absolute non-hazardous; MH - mirror hazardous; MNH - mirror non-hazardous.

high cost may be involved for landfilling (150 to 500 €/ton), the recycling/recovery options may become interesting alternatives in Europe.

This work aims to give an overview of a selection of recycling/recovery technologies for the management of APCr and FA generated in MSWI. The possibility of looking at these residues as anthropogenic resources with the potential for recovering secondary raw materials is put into perspective. Six technologies of different technology readiness levels and various secondary raw materials that can be produced were selected and are presented as case studies. Furthermore, the technologies and secondary raw materials considered in the case studies are discussed from a resource evaluation and classification point of view.

2. Global perspective

Data about the characterization of MSWI residues is huge, encompassing the total elemental composition, trace organic pollutant content, mineralogy, speciation and geochemical modeling, thermal behavior, leaching and physical properties. All of this information has a major bearing on the selection of the best way to manage APCr/FA from MSWI. Some reviews highlight the possibilities of management considering the available options in the waste hierarchy (Margallo

et al., 2015; Lindberg et al., 2015; Zacco et al., 2014; Lam et al., 2010a; Quina et al., 2008a, 2008b). Other remarkable studies compare several technologies based on life cycle assessment (LCA), giving clues to decide on the best methods (Huang et al., 2017; Boesch et al., 2014; Fruergaard et al., 2010).

Fig. 1 summarizes the six main routes identified in the recent literature to manage APCr/FA, two of them hampering further recovery (① backfilling and ② treatment + landfilling) and four methods with potential for recovery of raw materials or manufacture of products (③ detoxification, ④ product manufacturing, ⑤ practical applications and ⑥ recovery of materials).

Disposal of MSWI residues containing water soluble salts and potentially toxic metals can be conducted safely through backfilling of old salt mines and cavities in the underground, avoiding leaching with water (Astrup, 2008; Fruergaard et al. 2010). APCr/FA may also be packed in "big bags" made of a resistant material before backfilling.

Although the EU legislation focuses on reducing the environmental impact caused by disposal sites, APCr/FA have been mostly treated by stabilization/solidification (S/S) before landfilling. This technology has economic advantages, but does not produce inert waste or facilitate recovery of materials. In the literature several formulations and strategies have been applied (González et al., 2017; Ye et al., 2016; Jin et al., 2016; Zhang et al., 2016b; Huber et al., 2016; Qiu et al., 2016; Hu et al., 2016; Wachter et al., 2016; Li et al., 2016; Wang et al., 2015a; Alhadj Mallah et al., 2015; Quina et al., 2014a; Li et al., 2014; Guarienti et al., 2014; De Boom and Degrez, 2015; Cyr et al., 2012; Lundtorp et al., 2003). Thermal methods (sintering, vitrification and/or melting) have been used to attain environmentally stable materials, specifically with reduced leaching of inorganic pollutants while at the same time destroying harmful organics (Lindberg et al., 2015). The final material may be suitable for practical applications or it can be disposed of in landfills accepting non hazardous waste. The main disadvantage of the thermal processes is the high energy demand, causing high environmental loads/impacts in the life cycle assessment (LCA) of different treatment options (Fruergaard et al., 2010). The main weakness of S/S with binder or additives is that the mass increases and some deterioration of the final product may occur. Thus, both methods ① and ② do not promote the circular economy.

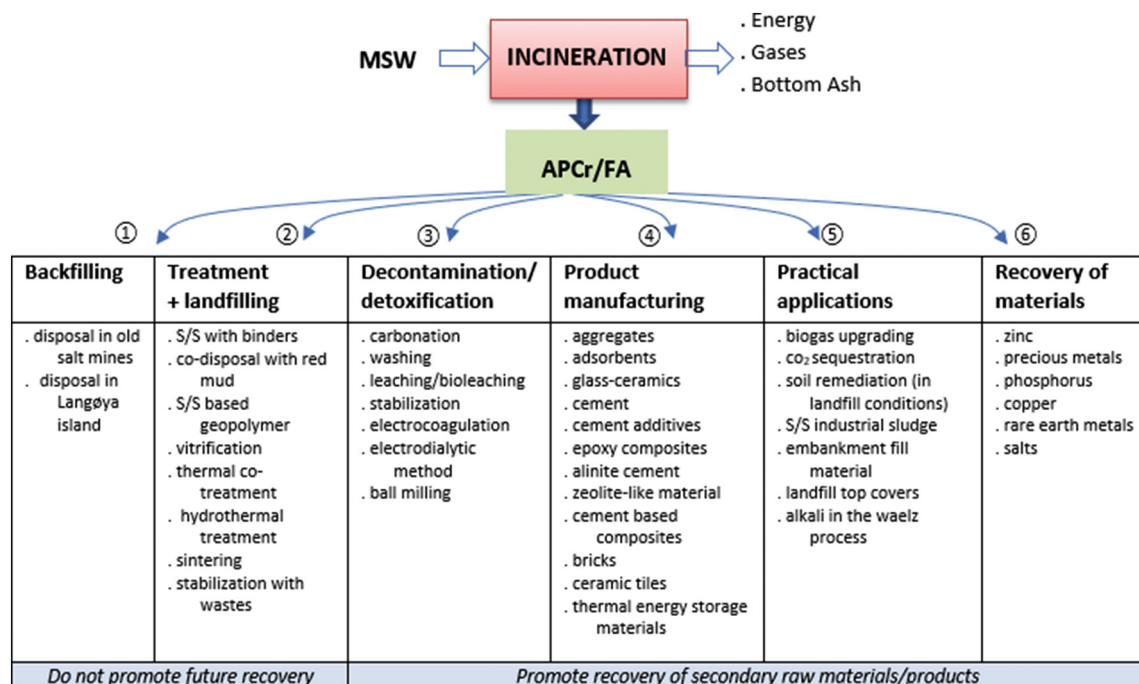

Fig. 1. Main routes to manage APCr/FA sourced from incineration.

An interesting option to encourage recovery is through detoxification of the waste by removing or destroying the harmful substances (toxic metals, salts or trace organic pollutants) or by decreasing the impact of such pollutants. Some of the methods referred to in Fig. 1 under route ③ may be based on the same technology as in ②. But the objective in category ③ is to prepare the material for further applications, promoting recovery instead of landfilling. Some of the methodologies identified in the literature are carbonation (Jiang et al., 2009; Ecke et al., 2003; De Boom et al., 2014), washing (Wang et al., 2015b; De Boom and Degrez, 2015; Chen et al., 2012; Wilewska Bien et al., 2007), leaching/bioleaching (Funari et al., 2017; Ramanathan and Ting, 2016; Fedje et al., 2010), chemical stabilization (Liu et al., 2016; Benassi et al. 2016; Bontempi et al., 2010; Quina et al., 2010), electrocoagulation (Liao et al., 2014), electro-dialytic method (Pares Viader et al., 2016) and ball milling (Chen et al., 2016). It should be emphasized that the technical properties of APCr may be significantly improved by washing either using water or acid solutions to remove salts.

The fourth route, ④, is the recovery of APCr/FA by manufacturing products. In this case, technical specifications have to be achieved while minimizing the impact on human health and environment. According to the physical and chemical properties of APCr/FA, the most promising applications are the ceramic materials (Belmonte et al., 2016; Jordan et al., 2015; Quina et al., 2014b, 2014c), glass ceramic (Luan et al., 2016; Ponsot et al. 2015), cement (Lederer et al. 2017b; Guo et al., 2016; Wang et al., 2016; Garcia Lodeiro et al., 2016), secondary building material/geotechnical applications (Colangelo et al., 2015; Valle Zermeño et al., 2013, 2014; Tu et al., 2010; Lin et al., 2016), epoxy composites (Goh et al., 2016), zeolite like material (Deng et al., 2016), adsorbent (Xue et al., 2014) and thermal energy storage materials (Meffre et al., 2015).

The route "practical applications", ⑤, is related to the direct utilization of APCr/FA for attaining a specific objective. Examples mentioned in the recent literature are the application for biogas upgrading (Bacocchi et al., 2013), CO₂ sequestration (Cappai et al., 2012), as a stabilizing or S/S agent (Travar et al., 2015a,b; Qian et al., 2006), embankment fill material (Zhang et al., 2016a), landfill top cover (Brannvall and Kumpiene, 2016) and as alkali (Huang and Chuieh, 2015).

Finally, route ⑥ refers to one of the most compelling possibilities, which corresponds to recovering specific elements or minerals. In fact, APCr/FA from MSWI contains a substantial amount of salts and metals, some of which are valuable and/or potentially toxic. In recent years efforts have been made to develop feasible methods to recover selected metals: Zn (Purgar et al., 2016; Fellner et al., 2015; Schlumberger et al., 2007), Cu (Lassesson et al., 2014; Karlfeldt Fedje et al., 2012), P (Kalmykova and Karlfeldt Fedje, 2013; Kalmykova et al., 2015), various metals (Tang and Steenari, 2015, 2016; Okada and Tomikawa, 2016; Kirkelund et al., 2015; Hu et al., 2015; Yu, et al., 2015; Liu et al., 2015; Meylan and Spoerri, 2014; Yang et al., 2013; Kubonova et al., 2013), precious metals and rare earth elements (Funari et al., 2016; Hasegawa et al., 2014; Morf et al., 2013). If the requisite technology could be developed, a significant amount of valuable metals might be reinserted into the industrial material loops.

3. Case studies

In this section, an overview of three products (lightweight aggregates, glass ceramics and cement) and three ways of recovering materials (zinc, rare metals, salts) will be presented. In the following sections, all percentages refer to weight basis.

3.1. Lightweight aggregates

The possibility of recycling APCr into synthetic lightweight aggregates (LWA) was assessed in previous studies (Quina et al., 2014b, 2014c). This ceramic material has been manufactured on an industrial scale by heating pelletized expansive clay in rotary kilns at high

temperature (close to 1170 °C) to promote the bloating process. The LWA has a dense ceramic shell with high mechanical resistance, which involves a lighter core with highly interconnected pores. Several technical advantages have been pointed out with regard to LWA, namely low bulk density (up to 50% lighter than natural aggregates due to honeycombed internal non interconnected pores), good thermal characteristics, sound insulation and fire resistance, low water absorption, good chemical resistance in alkaline and acidic conditions and high durability. Most of these properties are dependent on the aggregates size, and higher density and strength are observed for smaller aggregates. Accordingly, LWA has been used to produce lightweight concrete, insulation materials, geotechnical fill, as well as used for soil engineering and in drainage systems and roofs. The process implemented on a laboratory scale may be summarized according to Fig. 2.

Initially, both granular materials (clay and APCr) were homogenized by combining different proportions of clay: APCr in a range of 100:0, 99:1; 98:2; 97:3; 96:4; 95:5 and 90:10. Two additional formulations were considered using pre washed APCr for removing soluble salts (clay:APCr 95:5 and 90:10). To facilitate the granulation phase, for each formulation about 20% of water and 1% of waste lubricant oil (as expanding agent) were added. In order to better control the size of the green pellets, spherical granules were formed by hand, with a mean mass of 1.4 g and a median diameter of about 11 mm. Then, the pellets were dried at 200 °C for 2 h and fired at 1170 °C for 8 min in a furnace. The LWA produced were characterized with respect to bulk density, bloating index, compressive strength, water absorption capacity (WAC), porosity, leaching behavior in batch conditions (EN 12457 2) and in pH dependence tests (prEN 14429) and acid neutralization capacity (ANC).

The analysis of the external glassy shell revealed that >4% of "APCr as received" is detrimental to the external shell of the LWA. In the case of a washing pre treatment, about 5% of incorporation led to good results. In general, the bulk density and the compressive strength increased with the APCr amount, whereas the bloating index decreases. The WAC, which is related to the open porosity of the aggregates, also rose with the amount of APCr to 5%, whereas for 10% of the waste a reduction occurred. It is important to note that depending on the application of the LWA, a high WAC may be beneficial (Quina et al., 2014b). Regarding the assessment of the environmental impact, the leaching behavior of LWA revealed that the release of metals such as Pb, Cd, Zn, Cr, Ni and Cu will not be significant. In spite of the low ANC of the ceramic material, their sensitivity to external pH variations was not relevant since the pollutants were well immobilized into the glassy ceramic matrix.

The main outcome of the work is that after a washing pre-treatment or if the percentage of incorporation is low, APCr may be incorporated into LWA. While this recycling route did not reveal technical advantages, the environmental gains (in a life cycle perspective) may be of interest. Further investigation is required in this case, namely on a pilot scale.

3.2. Glass ceramics

A stabilization process of APCr, based on the use of amorphous silica waste sources, was proposed by Bontempi and co workers (Rodella et al., 2017). This method mainly requires the use of an amorphous silica source for toxic metals stabilization. It was originally based on the use of colloidal silica (Bontempi et al., 2010), but it evolved by substituting this material with more sustainable silica sources, such as rice husk ash (Benassi et al. 2016; Bosio et al. 2013) and silica fume (Bontempi, 2017b).

Colloidal silica is a concentrated stable dispersion of dense particles of amorphous silica. It is used in the form of a gel and made of a network of interconnected pores with a silicon dioxide core in which water gets trapped. It is a commercial material, generally very pure and quite expensive. Silica fume is a by product due to the ferro-silicon industry. It is formed by condensation from the vapor phase of silicon oxide. In

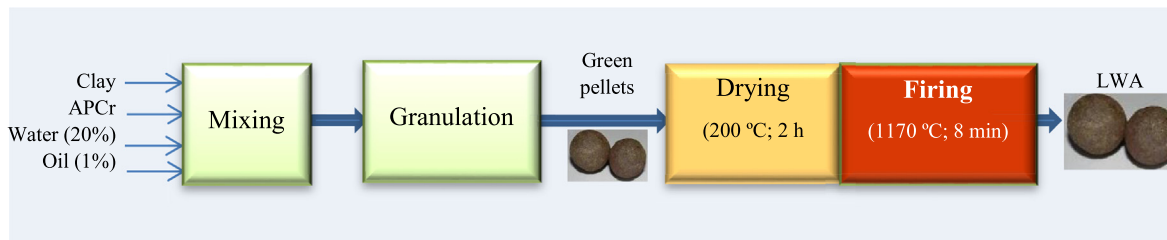

Fig. 2. Phases for producing LWA at laboratory scale.

this material, generally, 85% to 95% is in the form of amorphous silica. Rice husk ash is the outer shell enclosing the rice grain, and is considered an agricultural by product. When it is burnt, it is possible to obtain rice husk ash containing about 80% (even 90% in the case of proper combustion) of amorphous silica. As a consequence of their origin, both silica fume and rice husk ash can be found at low costs. The second main ingredient for APCr stabilization is another by product, i.e. flue gas desulfurisation (FGD) residues. FGD residues are obtained from the pre treatment made on coal in combustion plants to reduce the amount of sulfur. It is then generated by the air pollution control equipment of coal combustion plants, and contains large amounts of calcium hydroxide.

Very recently (Benassi et al., 2017) it was shown that, in the stabilization process, FGD residues can be substituted by wood ash obtained, for example, from the biomass combustion in home stoves. Indeed, the presence of CaO in these ashes makes wood biomass ash an alternative source of calcium hydroxide, derived from by products materials. This also makes this material available at no cost. Coal fly ash is also used (even if it is not fundamental material) in the stabilization process. Coal fly ash generated during flue gas cleaning at coal power plants is composed of mullite, quartz, magnetite, hematite and anhydrite and amorphous phases (Zacco et al., 2014).

The COSMOS technology was developed and optimized to use local available raw materials to treat APCr. It was also shown that it can be applied to APCr from different geographical origins.

The COSMOS powder obtained is an inert material, as shown by aquatic toxicological tests (Guarienti et al., 2014, Bilo et al., 2015). The reaction mechanism involving the metals' stabilization in APCr is mainly attributed to the amorphous silica reactivity. The amorphous silica surface is covered by silanol groups, which are responsible for physically adsorbing water molecules. The adsorption of metal ions seems to take place on the silica surface and can be explained on the basis of the surface complex formation model. In particular, a cation exchange reaction occurs due to the substitution of protons from silanol groups present on the amorphous silica surface by the metal ions contained in the solution (Srivastava et al. 2006). The stabilization of soluble toxic metals present in APCr can also be explained in terms of carbonation reactions. Carbonation of APCr naturally occurs as a result of contact with atmospheric carbon dioxide, and is commonly associated with a pH decrease

(Belevi et al., 1992) from 12 to 13 (strongly alkaline) to lower values (generally 8-10).

In the COSMOS technologies FGD residues, which contain calcium hydroxide, promote carbonation reactions that seem to have synergic effects with amorphous silica in the toxic metals entrapment (Bosio et al., 2014). In addition, carbonation leads to CO₂ sequestration, with high environmental advantages in terms of the CO₂ footprint. Structural analysis of the stabilized COSMOS material showed that it is mainly composed of calcium carbonates and silicates phases (crystalline and amorphous). Fig. 3 shows a schema of the COSMOS process, where the main materials used for stabilization are highlighted. In addition, some composite materials produced by using COSMOS are also shown. In deed, it is interesting to note that the stabilized material obtained is a glass ceramics powder which can be used in several applications (Ponsot et al., 2015; Benassi et al. 2015), namely as a filler of polymeric matrix (Besco et al., 2013). Actually, COSMOS also contain soluble salts (mainly NaCl and KCl), originally present in APCr. Therefore, direct reuse in cement manufacturing is not possible without removal of the salts in an additional step in filler preparation. Washing of the filler is possible (Bontempi et al. 2010) and it allows the recovery of almost pure salts. However, it results in an additional step in the APCr stabilization, with a consequent increase in the cost of technology. Polypropylene composites were synthesized by the addition of different amounts of COSMOS stabilized material and by making use of different sources of amorphous silica as a stabilizing agent (colloidal silica, rice husk ash, and silica fume). The mechanical properties of the composites were evaluated. The mechanical characteristics of the composites obtained, produced with the same amount of COSMOS stabilized material, were comparable, suggesting that a slight variation of the COSMOS composition does not affect the composite mechanical performances. In addition, the mechanical characteristics of the composites obtained are very similar to corresponding polypropylene composites produced by using calcite (a natural resource) as filler.

In Europe, the critical raw material initiative has highlighted the high European dependence on some raw materials that are imported from other countries. The possibility to develop new materials, for example those obtained from wastes, is a fundamental aspect for European competitiveness and growth. The use of COSMOS material in plastics has been proposed also in view of the sustainability of the



Fig. 3. Schema of the COSMOS process (the main materials used for stabilization are amorphous silica and calcium hydroxide). This Figure also shows some composites materials that have been produced by using COSMOS.

composite obtained when compared to a similar composite produced with commercial fillers. Indeed, in a very recent work (Bontempi, 2017a) it was demonstrated that if energies and emissions involved in the synthesis of fillers used for polypropylene manufacturing are considered and compared, the COSMOS filler can be considered an alternative to calcite. In addition, this new material is more sustainable than talc, which is another natural filler often used for synthesis of plastic composites. Furthermore, Bontempi (2017b) showed that COSMOS material increases the thermal stability of the polypropylene composite. It was subsequently proposed to investigate the possibility to employ this material as a substitute of Sb, a critical raw material used as a fire retardant in plastic composites.

3.3. Cement

Cement is the most widely used building material in the world, with nearly 450 kg of cement being consumed yearly per capita and a growth rate in consumption of >100% between 2004 and 2014 (Edwards, 2015; Van Oss, 2015; WBCSD, 2014). Ordinary Portland cement (OPC) and blended cement as defined in the European Standard EN 197 1 (CEN, 2000) are the most commonly types of cement used. The production of OPC involves the following main steps: 1) preparation of a material mixture consisting of mainly limestone, clay, sand, and iron oxides;

2) pre calcining in the pre heating system to initiate the dissociation of calcium carbonate to calcium oxide and carbon dioxide and subsequent burning of the material mixture in the cement kiln at a temperature of up to 1450 °C to produce Portland cement clinker; 3) grinding and mixing of the cooled Portland cement clinker with small amounts of calcium sulfate like gypsum or anhydrite, resulting in OPC that contains >95% Portland cement clinker (WBCSD, 2014; Parlikar et al., 2016). Blended cements are mixtures of Portland cement clinker and major constituents like coal fly ash, pozzolanic materials, or granulated blast furnace slag. Other cement types not covered in the EN 197 1, like supersulfated or pozzolan lime cements, contain lower if any amounts of Portland cement clinker, but therefore other constituents. However, their relevance in terms of market share is negligible compared to OPC and cement blends (Müller, 2012). The main environmental issues in the cement industry are: 1) the large contribution of about 5-8% to the global man made CO₂ emissions, of which 50% comes from calcination, 40% from the burning fuel and 10% from electricity consumption and transportation (WBCSD, 2005; Kim et al., 2016); 2) the consumption of enormous amounts of natural resources like clay and limestone as well as energy (Madlool et al., 2011; Stafford et al., 2015); and

3) other gaseous emissions from cement production like NO_x, organic compounds, or toxic metals (EIPPCB, 2010).

The presence of Ca, Si, Al, and Fe bearing phases in APCr/FA (Astrup, 2008; Quina et al., 2008a; Bogush et al., 2015) shows the

potential to use these wastes as raw materials in the cement industry, thereby replacing natural raw materials like limestone, clay, shale, etc. Lederer et al. (2017a) showed that the scientific interest in the utilization of APCr/FA in the cement industry has vastly increased in recent years. The main options for APCr/FA utilization in the cement industry are presented in the article at hand, namely 1) production of blended cement and 2) co processing of residues in the cement kiln to produce cement clinker (Fig. 4).

Several researchers have studied the possibility of recycling raw and untreated APCr/FA as a major constituent to produce blended cement since some of their properties may positively influence the hydration behavior of the cement (Rémond et al., 2002; Goh et al., 2003; Shih et al., 2003; Shi and Kan, 2009; Keppert et al., 2012; Chen et al., 2013; Kim et al., 2016). Goh et al. (2003) showed that up to 10% of Portland cement clinker could be replaced by FA from a Singapore MSWI plant to produce blended cement with higher mortar strength being achieved than for OPC. Keppert et al. (2012) analyzed the physical and chemical properties (composition, morphology, hydration behavior) of boiler FA, electrostatic precipitator FA and bottom ash in comparison to coal FA, concluding that the MSWI FAs are a suitable major constituent for blended cements if applied in untreated and raw form. Kim et al. (2016) used MSWI FA to replace 10%, 20%, and 30% of cement, finding that all of these blended cements reached the limit values for compressive strength. However, they indicated that FA contained a considerable amount of metallic aluminium that generated the hydrogen gas causing volume expansion of cement paste. In order to remove chlorides present in the APCr/FA to an acceptable limit, many studies suggest water washing or acidic leaching of APCr/FA. Keppert and Polozhiy (2014) showed that washed FA can be used as 10% Portland cement substitute with appropriate mechanical properties. Gao et al. (2008) tested different cement mortars with a cement substitution by washed MSWI FA (liquid to solid ratio L/S = 5, residence time $t = 30$ min) of 10, 20, and 30%, finding the acceptable substitution rate up to 20% in order to maintain the strength of the mortars. However, the authors judge the chlorine content of 1.3% after washing (reduced from 10% before washing) as too high, particularly if compared to the limit value of 0.1% chloride applied to coal fly ash according to EN 450 1 (DIN, 2012). Hartmann et al. (2015) used washed FA (L/S = 10, $t = 24$ h) to replace cement and showed the following removal rates of chlorides: 82% after 1 h, 98% after 2 h, and 99.6% after 24 h. Authors concluded that 30% substitution is appropriate to make mortar reach the compressive strength limit. However, water washing pretreatment can cause a loss of pozzolanic activity (Keppert et al., 2012) and decreases the compactive strength (Rémond et al., 2002) of mortars containing washed MSWI fly ashes. Therefore, mechanochemical treatment (e.g., dry or wet milling process) can modify the APCr/FA characteristics and induce the pozzolanic reaction in blended cement paste (Chen et al.,

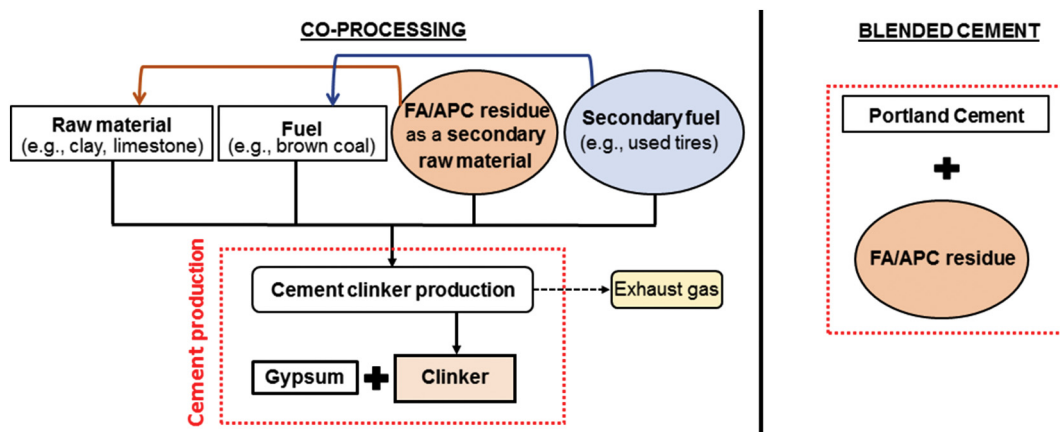

Fig. 4. The main options for APCr/FA utilization in the cement industry.

2013). With respect to reducing the content or mobility of toxic elements and organic pollutants present in APCr/FA, the Danish Environmental Protection Agency DEPA proposed using electro-dialytic (ED) treatment of APCr on a pilot scale in order to reduce the mobility of toxic elements and salts. The agency further proposed using treated residues as a secondary material for substitution of cement or fillers in concrete (DEPA, 2016). Moreover, wet milling of APCr/FA with different additives (e.g., CaO, ethanol, H₃PO₄) may lead to the decomposition of organic pollutants (e.g., PCDD/F) and to the stabilization of metals (Nomura et al., 2005, 2008; Li et al., 2010; Chen et al., 2013). Moreover, Gao et al. (2008) proposed adding dithiocarbamic chelate to the mortars in order to avoid the long term-leachability of potentially toxic metals. Most studies, however, show that the leaching values of contaminants from blended cement pastes and mortars containing APCr/FA complied with appropriate standards, but more investigation in the long term leaching behavior of potential pollutants is required (Goh et al., 2003; Shi and Kan, 2009). The Danish EPA is currently conducting a comprehensive study of the content, leaching and environmental impact of potentially problematic substances from recycled concrete aggregates used in construction applications.

Co-processing of wastes such as APCr/FA in cement kilns to substitute parts of the raw meal, which is situated in the waste hierarchy in between recycling and energy recovery (CEMBUREAU, 2009; WBCSD, 2014), has been suggested as an alternative to landfill disposal for wastes containing high amounts of Ca bearing phases, such as Ca(OH)₂, CaO, CaCO₃, and CaOHCl present in APCr/FA (Chandler et al., 1997; Astrup et al., 2005; Quina et al., 2008a, 2008b; Amutha Rani et al., 2008; Bogush et al., 2015). APCr/FA contain lower carbon bearing phases compared to limestone, thus it decreases CO₂ emissions, which is one of the main issues for the cement industry (Guo et al., 2016; Bogush et al., 2017). At the same time, co processing of MSWI residues in the cement kiln leads to the complete destruction of toxic organic compounds present in these wastes, but only if cement kilns are adapted to this type of waste co processing (Lorber et al., 2015). Co processing of MSWI FA has been investigated on a laboratory scale in a number of studies (Shih et al., 2003; Saikia et al., 2007; Pan et al., 2008; Lam et al., 2010b; Wu et al., 2011). Shih et al. (2003) showed that using the pre treated (e.g., magnet repelled) MSWI ashes of up to 5% of the raw meal is applicable for co processing. Saikia et al. (2007) used untreated and washed (L/S = 20) MSWI FA (40-50%) to produce a cement clinker under 1300-1400 °C, showing that >85% of Cd and Pb was volatilized during the process. In practice, however, these elements are incorporated into the cement again by recycling of the cement kiln filter dust (Lederer et al., 2017b). Lam et al. (2010b) showed that the addition of up to 8% FA may lead to insufficient CaO for alite formation. Wu et al. (2011) used untreated FA (15-44%) to produce clinker at 1150-1300 °C for sulfoaluminate cement, which is a special cement type not included in the EN 197 1. Even though a maximum additional share of 30% of FA is possible, the authors recommend in their conclusion further investigation of the impact of chloride present in the FA on the operation of the cement kiln. Guo et al. (2016) used 30% of untreated FA to produce non EN 197 1 conform but CO₂ reduced alinate cement with high strength and durability (shrinking, carbonation, water permeation, and reinforcement steel corrosion). Most of the above mentioned researchers concluded that a proper pre-treatment would be required to use APCr/FA in co processing in order to remove soluble Cl and S bearing phases and prevent cement kiln operation problems (Saikia et al., 2007; Pan et al., 2008; Lam et al., 2010b; Guo et al., 2016; Bogush et al., 2017). However, most investigations suggest that the short term leaching rates of pollutants (e.g., toxic metals) from the co processed cement pastes were very low (Lam et al., 2010b; Wu et al., 2011; Guo et al., 2016). Contrary to that, gaseous emissions during co processing are a subject that should receive more attention by researchers (Saikia et al., 2007; Bogush et al., 2017; Lederer et al., 2017). Since the composition of MSWI ash may not be stable over time (due to diverse sources of MSW, incineration technologies and gas cleaning

systems), some influence on the cement quality or the emissions from the cement kiln stack may occur. Therefore, a systematic monitoring of the APCr/FA composition is required before its application in the cement industry. The metabolism of toxic elements (e.g., Pb and Zn) presented in APCr/FA in co processing is still poorly understood and needs detailed investigation. The presence of high chloride content in APCr/FA may affect the product quality and cause technical problems in the cement kiln (e.g., rapid clogging, corrosion inside the heat exchangers, in creasing metals emission, etc.). Therefore, pre-treatment (e.g., water washing) is recommended before further application. The quantity of APCr/FA added should be carefully controlled in order to ensure the process safety as well as product quality.

3.4. Recovery of Zn, Cu, Cd, Pb

Volatile toxic metals such as Zn, Pb, Cd and organic substances (e.g. PCDD/F) are accumulated in FA from MSWI. In Switzerland, acidic fly ash leaching (FLUWA process depicted in Fig. 5) has been established since 1997 and offers an effective method for metals separation and recovery, as described in detail by Bühler and Schlumberger (2010). The depleted residue (filter cake) has less impact on the environment and can be deposited together with BA on a landfill type C or D according to the Swiss Waste Ordinance (Swiss Confederation, 2016). Alternatively, organic substances remaining in the low metal content filter cake (predominantly PCDD/F) can be returned to the incineration process for complete thermal destruction.

Nowadays, >60% of FA in Switzerland is treated according to the FLUWA process, which represents a state of the art technology. Scrub waters from the wet flue gas cleaning process for extraction of metals in FA was first used in the 3R process by Vehlow et al. (1990). Within the FLUWA process, FA is most often leached using both acidic and neutral scrub water in a multistage cascade (Fig. 5). Prior to FA leaching, mercury dissolved in the acidic and neutral scrub water is separated by a selective ion exchanger. The extractability of metals such as Zn, Pb, Cu and Cd is mainly dependent on the characteristics of the FA, acidity of the scrub water, L/S ratio, redox potential, temperature and leaching time. Depending on these parameters, 60-80% Zn, 80-95% Cd and 50-85% Pb and Cu can be extracted by the FLUWA process (AWEL, 2013; Weibel 2017). By adding hydrogen peroxide to the FLUWA process, the redox sensitive metals (mainly Pb, Cu and Cd) remain in solution. In addition, Fe²⁺ is converted into Fe³⁺, which precipitates as Fe hydroxide and is accumulated in the remaining filter cake. After sufficient extraction time, the suspension is separated by vacuum belt filtration into a metal depleted filter cake and a metalliferous filtrate. The FLUWA process provides the basis for extended methods such as the FLUREC process. This process allows the recovery of high purity zinc (Zn >99.995%) from the heavy metal enriched filtrate, as described in detail by Schlumberger et al. (2007) and Bühler and Schlumberger (2010). The FLUREC process was implemented at MSWI plant Zuchwil, Switzerland in 2012, where about 300 tons of Zn can be recovered annually (Fig. 6). Thereby Cd, Pb and Cu from the filtrate of the FLUWA process are separated by reductive separation (cementation). For this purpose, Zn powder is added to the filtrate as a reducing agent whereas metals comparatively more noble than Zn are separated as metallic cement. This cement, with a high Pb load of 50-70%, can be sent directly to a lead smelter where metals are recovered in the Pb production process.

A solvent extraction step separates and purifies the remaining Zn selectively from the filtrate by extracting it in a water insoluble organic phase. The complexation of Zn is strongly pH dependent and at low pH (pH 2.7-3), 99.5% of the Zn is extracted by the organic phase. To reduce interference in the subsequent Zn electrowinning, other metals and impurities present in the organic phase are removed in a washing step. The Zn loaded organic phase is regenerated using sulfuric acid obtained as by product from the electrowinning section. There, direct current is applied to the resulting high purity zinc sulfate solution, and

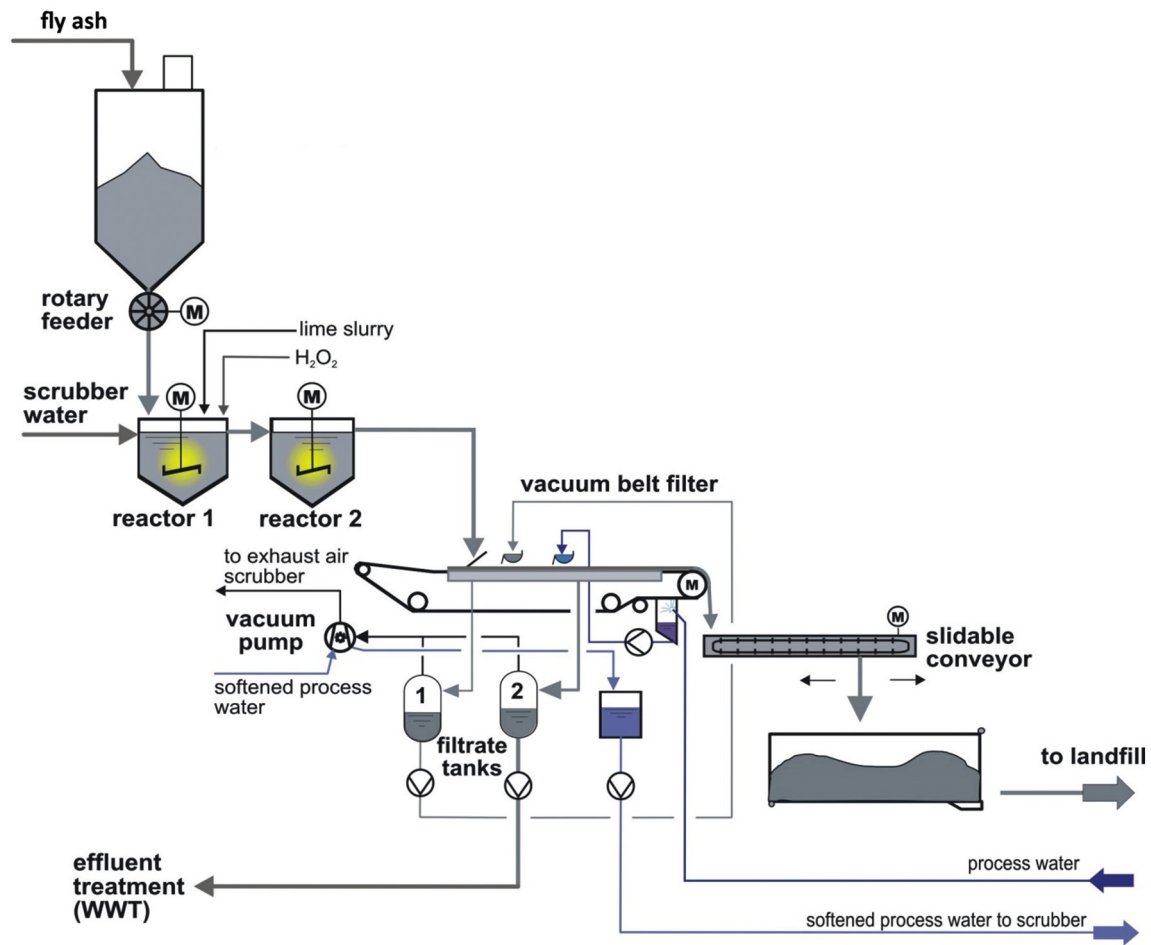

Fig. 5. Basic concept of acidic fly ash leaching (FLUWA).

special high grade Zn is recovered on aluminium cathodes. The recycled Zn metal is sold on the market. If a direct metal recovery is not possible as in the case of the FLUWA process the metalliferous filtrate has to be fed to a wastewater treatment plant where metal hydroxide sludge precipitation is performed. The resulting zinc-hydroxide sludge with a dry mass of 17-35%, depending on the filtration system, is then exported abroad and metals are recovered in smelting plants.

Until the year 2021, all FA produced in Switzerland must be treated and metals have to be recovered according to state of the art procedures as prescribed in the Swiss Waste Ordinance. Therefore, the construction of a central hydroxide sludge treatment plant with integrated metal recovery similar to the FLUREC process is planned in Switzerland (SwissZinc). A decision on the implementation of a central processing plant under the leadership of the Association of Swiss Operators of Thermal Waste Processing Plants (VBSA) is expected by mid 2018.

3.5. Recovery of rare earth elements and other rare metals

The rare earth elements (REE) represent key components in many industrial applications (Hatch, 2012) and their supply, as oxide or pure metal, derives from the mining and processing of geogenic deposits. Nearly 40% of the total world reserves of REE are in China, which is also the largest producer, with >80% of the global mine production (USGS, 2017). Ore processing and REE production usually imply strong acid leaching followed by metallothermic refining and requires a large quantity of water, acids and electricity, thus implying high costs and production of harmful by products. The REE demand coupled with the supply risk associated with China's predominance as REE

producer has pushed the interest in exploring the REE potential from alternative sources. The recent availability of concentration data (at mg/kg level) on solid residues produced after the treatment of different types of waste (Morf et al. 2013; Funari et al., 2015 and references therein) reveals that MSWI solid residues have total REE contents at 10⁰-10² mg/kg level. Despite the low absolute concentrations, substance flow analysis on selected Italian MSWI plants showed that FA and BA can be regarded as a low grade stream of high tech metals, with calculated annual flows of tens of kg (Funari et al. 2015) of valuable metals. The low concentrations in the starting materials make any extraction process borrowed from primary ore mining uneconomic (Binnemans et al., 2013). However, there are potentially extractable resources with a total content comparable to low grade active mines (Funari et al., 2015).

The bioleaching is a mature hydrometallurgical technology which relies on microorganisms to solubilize metals. This method has only recently been investigated as a potential route for the valorization of waste streams, as a pre treatment method or a means of removing certain metals. Bioleaching is widely employed commercially for processing low grade ores as it exploits microorganisms that can produce mineral or organic acid (as metabolites) and enhances metal solubility through enzymatic reactions (e.g., pyrite oxidation). An excellent overview of suitable microorganisms for metals recovery is provided by Rawlings (2002). The approach benefits from low energy input, low capital cost and improvement in the general healthiness of the workplace compared to classic leaching methods. The bioleaching of Al, Cu, and Zn from MSWI ashes can be suitable for economic recovery using fungi, mixed acidophilic bacteria (Lee and Pandey, 2012) and mixed alkaline bacteria (Ramanathan and Ting, 2016), but there are no

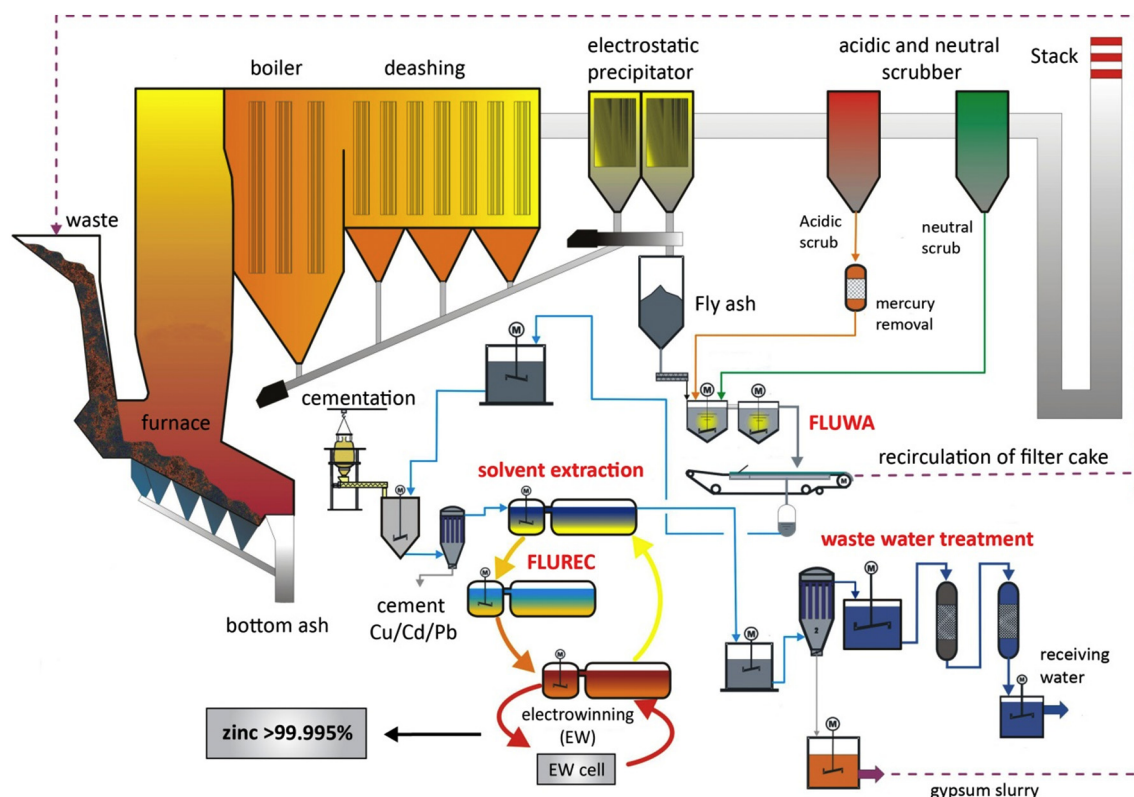

Fig. 6. Process diagram of waste incineration, fly ash leaching (FLUWA) and recovery of recyclable materials (FLUREC).

bioleaching processes applied on a full scale. Although data from fungal and alkaline bioleaching are less encouraging due to substantial disequilibrium between metal removals, biomass produced, and duration of the experiment, acid bioleaching using mixtures of acidophile/extremophile bacteria, seems to be a scalable process. In all these lab studies, one step and two step bioleaching were tested. The one step bioleaching is performed where the microorganism is inoculated together with the ash to be treated in the medium, and microbial growth and metal leaching occur simultaneously. In two step bioleaching (or spent medium leaching), after the maximum growth of the microorganism and consequent maximum production of metabolites has occurred, the suspension is filtered and only the supernatant is used for leaching (Pandey and Natarajan, 2015). In a recent work (Funari et al., 2017), the bioleaching behavior of MSWI FA of a wide range of metals was investigated on the bench scale. The one step bioleaching process involved a mixed acidophilic culture, where sulfur and iron oxidizing bacteria are the dominant strains. The procedure employed (acidic culture medium, 10% pulp density, 150 rpm, 30 °C) yielded in the leachate solution ~90% Al, Mg, Mn, Zn; ~80% Cu, P, Nd; ~60% Cr, Ga, Ni, Pb; ~50% Ce, Co; 30% La. Compared to a traditional leaching procedure (H₂SO₄, 10% pulp density, 150 rpm, 30 °C), this bioleaching process resulted in satisfactory removals, suggesting a greener alternative to other solvents. Moreover, the results revealed a low mobility of unvalued elements such as Ca, Si, Fe, and Ti, selective removals of Co, Cr, Pb and REE, and low capital costs. While unvalued elements displayed the tendency to remain (or re precipitate) in the solid phase as hydroxides and sulfates, the solubilization of Co, Pb and REE (probably associated to S Fe rich minerals in FA), might be enhanced by Fe³⁺ produced by iron oxidizing bacteria. Alternatively, lanthanides can accumulate on cell wall or bacteriogenic oxides (Moriwaki and Yamamoto, 2013) and the selectivity difference to REE might be explained by the direct contact between microbial biomass and ash sample.

Funari et al. (2016) showed via magnetic methods and chemical analysis that iron rich FA and APCr contain the highest REE total concentration. World class REE primary deposits indeed occur in sulfur

and iron rich minerals (Kynicky et al., 2012). The application of (high field) magnetic separation to obtain a REE rich separately, which facilitates further valorization, can be implemented as a pre treatment in a project on an increased scale.

Fig. 7 suggests a strategy to recover REE and other metals from MSWI FA. The culture supernatant generated in a separate bioreactor mobilizes metals from FA. After filtration, an improved solid material is sent to landfill or reused (Funari et al., 2017) and the metal rich leaching liquor is further processed for metal recovery by conventional methods such as fractional crystallization, elution, ion exchange and electro-winning. Reusable ion exchange resins or commercially available extractants can be successfully applied to extract REE from sulfuric acid leach solution (Xie et al., 2014). The performance of each method may vary depending on the chemical composition of the starting FA and could be limited by the presence of interfering ions. So, further research is needed to minimize interference and maximize metal recovery.

Two step bioleaching can be optimized to quickly generate higher amounts of supernatant prior to the addition of materials to be treated and the poisoning of microbial biomass, which may occur in a one step bioleaching during the adaptation of microorganisms to the waste substrate. This, in turn, would imply i) acceptable reaction time; ii) higher waste processing capacity when compared with the one step process; iii) the potential increase of temperature in reactor 2 (Fig. 7) that can be different from the microbial growth phase (reactor 1). Moreover, as the bacteria are not in direct contact with the metal containing waste, the latter can be more easily recycled or reused as it is not contaminated by microbial biomass. However, obtaining enough supernatant to process high waste quantities requires large volumes and the generation of considerable amounts of (harmless) microbial biomass. The excess of biomass goes either to the combustion chamber for complete thermal destruction or in reactor 3 for further bioleaching (one step) of the solid residue from reactor 2. A magnetic separation would provide a better material for bioleaching and subsequent recovery of REE from FA, although further testing is required.

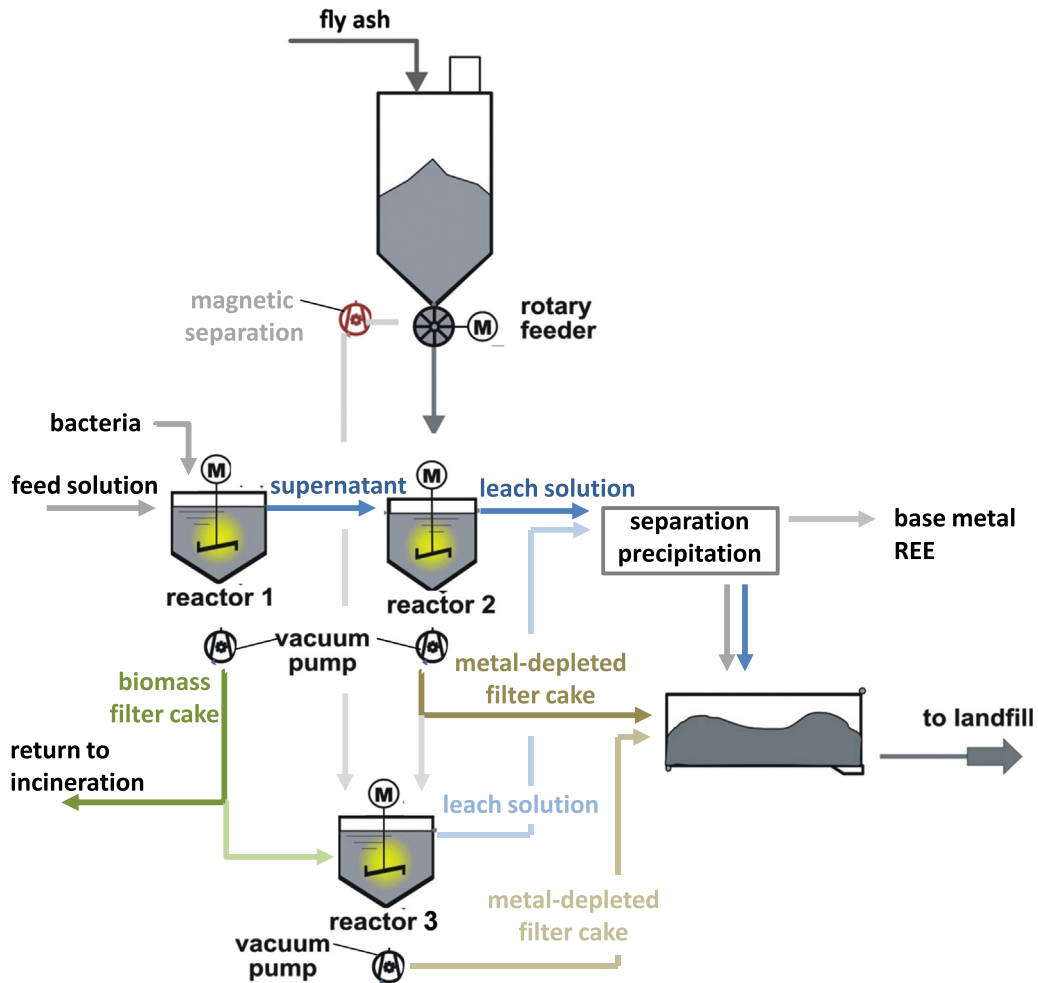

Fig. 7. Basic concept of a bioleaching process for enhanced REE removal and subsequent recovery.

3.6. Salt recovery

Despite significant amounts of readily soluble salts (Cl, Na, K, and Ca) in FA and/or APCr, historically, the major objective of the washing process has been the removal of the salts prior to further treatment and/or landfilling rather than its actual recovery (e.g. Chandler et al., 1997; Hjelmar, 2013). In general, further treatment of the washed residue such as chemical stabilization using e.g. phosphoric acid and/or carbon dioxide (Hjelmar et al., 2001; Hjelmar et al., 2006; Gunning et al., 2012), different complexing additives (e.g. GEODUR additive) or iron sulfate (Lundtorp et al., 2003) may be necessary to obtain a product which meets the requirements for acceptance at landfills within the European Union (EC, 2003).

The wastewater resulting from the washing of APCr/FA has typically a high content of salts and low to moderate amounts of toxic metals. Nevertheless, the wastewater can be treated to reduce the concentration of metals to an acceptable level by conventional methods (pH adjustment, TMT 15 addition and filtration). Then, it is possible to recover predominantly CaCl_2 and/or to discharge the salty effluent to a wastewater treatment plant (WWTP) or a water body (Hjelmar, 2013 and references therein).

HALOSEP® (by Stena Recycling A/S) is a process developed to remove/recover chlorine from APCr/FA generated at MSWI equipped with a “wet” and/or “semi dry” flue gas cleaning (FGC) system (cf. Chandler et al. (1997) for additional information), while the leaching properties of the treated solids comply with the EU landfill acceptance criteria. Besides the recovery of chlorine, the process allows for up

concentrating of, especially Zn in the form of a filter cake which can be processed at Zn smelters. Finally, since a large part of APCr/FA transforms into recyclable products, the landfilled quantity decreases. More specifically, HALOSEP® is based on washing/neutralization of the alkali APCr/FA (pH >11.5) using acidic scrubber liquid (pH <1) generated during the FGC at MSWI equipped with a “wet” FGC system. Typically, the residues from a “wet” system consist of dry FA collected in electro static precipitator(s), which may sometimes be mixed with a metal containing sludge from the neutralization of scrubber liquid. In addition, gypsum is produced as a separate stream from a SO_x removal, while process wastewater is treated at a WWTP.

Fig. 8 depicts the HALOSEP® process, where FA reacts with the hot scrubber liquid coming directly from the HCl scrubber, thereby forming a salt brine, water, $\text{CO}_2(\text{g})$ (not shown in figure) and neutralised/washed FA.

The salt brine is purified by a two stage precipitation, yielding a salt product and a metal filter cake. In the end, the treated FA has significantly improved leaching properties owing to the removal of salts and lowered pH, while its mass is reduced compared with the incoming FA amount (discussed later). APCr generated from a “semi-dry” system (mixture of FA, neutralization products from scrubber and baghouse filter ash) can also be treated with HALOSEP®. However, an external supply of the acidic scrubber liquid must be ensured since it is not produced in the “semi dry” system. Similar to the treatment of FA, the APCr react with the acidic scrubber liquid while both FA and the surplus lime present in the APCr are utilized in the neutralization reaction; outputs from the process are the same.

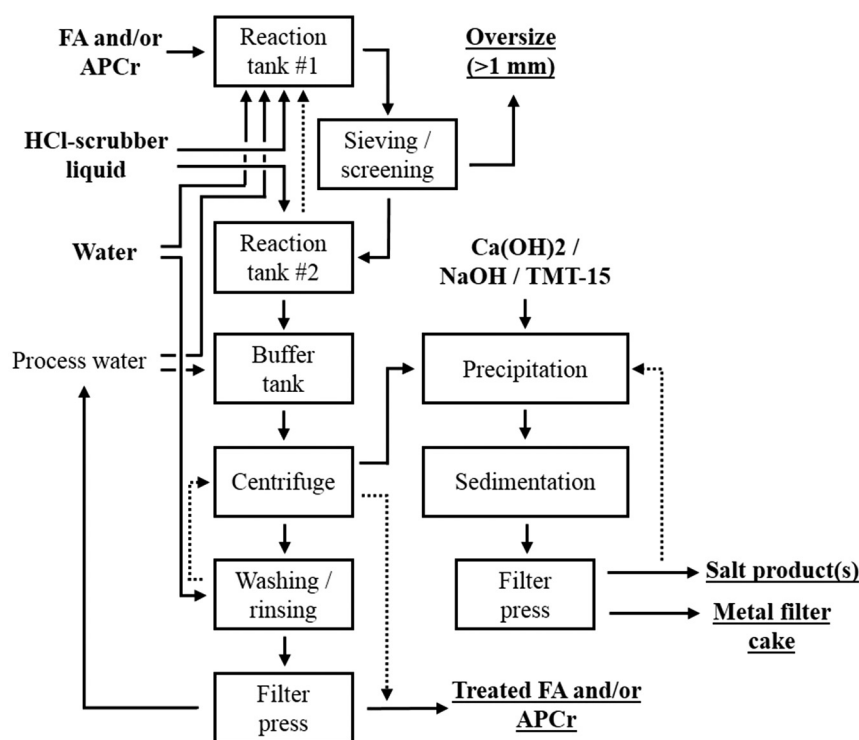

Fig. 8. Outline of the HALOSEP® (Stena Recycling A/S) showing main inputs/reactants (indicated bold) and outputs (bold; underlined).

As shown in Fig. 8, there are four output streams (excluding water and $\text{CO}_2(\text{g})$): treated APCr/FA; salt products; metal filter cake; and an oversize (>1 mm) fraction. Note that water and $\text{CO}_2(\text{g})$ generated in the neutralization reaction account for 5–12% of the overall mass balance (Table 3).

HALOSEP® treatment reduces the amount of residues which need to be landfilled by $\leq 40\%$ (FA) and by $\leq 60\%$ (APCr). Currently, the leaching of As, Ba, Cd, Cr tot, Cu, Hg, Mo, Ni, Pb, Sb, Se, Zn, chloride, fluoride, sulfate, and dissolved organic carbon (DOC) from treated APCr/FA complies with the European leaching limit values for acceptance at landfills for hazardous waste while Stena Recycling A/S is working on improving the leaching of Sb, which would allow for the treated FA to be accepted at landfills receiving stable, non reactive hazardous waste (EC, 2003).

Salt products generated by treatment of FA and APCr correspond to respectively 25–30% and 42–50% by weight of the incoming solid (Table 3). Higher amounts of salt product generated during the treatment of the latter residue reflect higher chlorine content (Chandler et al., 1997). Different salt products can be generated by HALOSEP® based on available management options: brine (10–15%) currently intended for road de icing (Option A) and salt water (Option B). It is possible to switch between Option A/B without modifying the process based on the actual demand. In winter periods Option A is better, while in summer periods Option B (discharge to a WWTP) may be preferred. Approximately 99% of the dry matter content of the salt product is composed of a mixture of CaCl_2 , NaCl, and KCl. In addition, 0.5–1% of the dry matter content is composed of CaSO_4 and MgSO_4 . The content

Table 3

The weight distribution of different output/process streams in HALOSEP® achieved during treatment of FA and/or APCr, respectively.

	Outputs (FA)	Outputs (APCr)
Treated FA or treated APCr	60–61%	40–48%
Salt product(s)	25–30%	42–50%
Metal filter cake	~3%	~2%
Oversize (>1 mm) fraction	~1%	<1%
H_2O and $\text{CO}_2(\text{g})$	5–8%	8–12%

of toxic metals in the brine for de icing is significantly below the limit values for de icing agents set by CEN TC 337 WG1.

The amount of the metal filter cake generated by HALOSEP® corresponds to approximately 2–3% by dry weight of the incoming APCr/FA. It is possible (both technically and economically) to wash and dry the filter cake obtained from the treatment of FA in order to reach a Zn content of 38–40%, which makes it feasible to send the material for recovery at zinc smelters. On the other hand, the filter cake generated by treatment of APCr shows a much lower Zn content (7–10%) and, consequently, the recycling potential of this fraction is limited from an economic point of view.

The oversize fraction, corresponding to <1% by weight of the incoming APCr/FA, has a total organic carbon (TOC) >5% and is sent back for incineration.

Based on a recent report by Stena Recycling A/S for Danish EPA (Rasmussen, 2015), the most economical solution seems to be a centralized HALOSEP® plant built within (or near) an existing MSWI equipped with a “wet” FGC system that can accept and treat residues from several MSW incinerators, including those equipped with a “semi dry” system. Currently, a demonstration HALOSEP® plant is being built in Copenhagen, Denmark. The plant should be operational from 2019.

3.7. Summary

Besides the six case studies mentioned, a number of other processes to recover secondary raw materials from APCr/FA have been designed and tested, most of them on a laboratory scale. The six case studies presented give an overview of current activities in this direction at the European level. Table 4 summarizes some aspects, properties, requirements, but also challenges towards full implementation of the technologies presented in the case study.

4. Future perspectives of APCr/FA as an anthropogenic resource for secondary raw materials

The development of alternative APCr/FA treatment technologies is a response to the discontentedness of contemporary European societies

Table 4

Overview of the characteristics of six case studies for the recovery of secondary raw material from APCr/FA from MSWI.

Case study	Inputs	Products/raw materials	Process wastes	Requirements/beneficial prop.	Technology readiness	Open questions and challenges (selection)
Lightweight aggregates	APCr	Lightweight aggregates	Off-gas	Low content of pollutants	Lab scale	Air pollution, leaching from product, economic viability
Glass ceramics	APCr/FGD	Silica and Ca(OH) ₂	–	Low content of pollutants	Lab scale	Leaching from product, economic viability
Cement	APCr/FA	Cement	Off-gas	Low content of pollutants	Industrial scale	Air emissions, leaching from product
Recovery of Zn, Cu, Cd, Pb	FA	High quality products: SHG Zinc (99.995%)/metal concentrate (Pb/Cu/Cd)	Leached FA-residue to landfill (non-hazardous waste), purified waste water	Wet flue gas cleaning, high metal content	Industrial scale	Economic viability
Recovery of REE	FA	Metal concentrate	Residues to landfill, waste water	Wet flue gas cleaning, high REE content	Lab scale	Economic viability
Salt recovery	APCr/FA	Salt/metal filter cake	Residues to land-filling	Wet flue gas cleaning, high metal content	Industrial scale*	Energy demand, economic viability

* A demonstration plant is under construction in Denmark.

with the current practice of landfilling. Thus, the technologies presented in Section 3 not only aim to reduce the hazardousness of APCr/FA, but also to extract different types of secondary raw materials from this anthropogenic resource. This shift in objectives of APCr/FA management from solely safe disposal towards resource recovery also calls for a revision of approaches to evaluate APCr/FA management technologies. One option for evaluating and classifying anthropogenic resources like APCr/FA and the corresponding technologies for secondary raw material production is to follow the procedures as applied in mining primary raw material deposits from natural resources, which generally follows a step wise approach of prospecting, exploration, evaluation and classification of anthropogenic resources (Lederer et al., 2014). For the evaluation and classification of anthropogenic flow resources like APCr/FA, first attempts were made by Fellner et al. (2015) by applying the so called McKelvey box of the USGS. A more promising approach in this direction, however, is the United Nations Framework Classification for Fossil Energy and Mineral Reserves and Resources 2009 (UNFC 2009)

by the UNECE (2010), shown in Fig. 9. Winterstetter et al. (2016), for instance, applied this approach to anthropogenic resources such as old landfills, obsolete computers and wind turbines. In an upcoming article, Huber and Fellner (2018) use UNFC 2009 to evaluate and classify the recovery of metals by means of FLUREC and the utilization in cement clinker production, both also combined with salt recovery, of a typical FA from a grate incinerator in Vienna. UNFC 2009 basically consists of three evaluation and classification criteria, namely geological knowledge (x axis), project feasibility (y axis), and socio-economic viability (z axis).

4.1. Geological knowledge (x axis)

Applied to the anthropogenic resource APCr/FA, geological knowledge (x axis) refers to its physical properties for secondary raw material production, typically substance contents and mineralogy. The corresponding database, however, has not yet been completely established

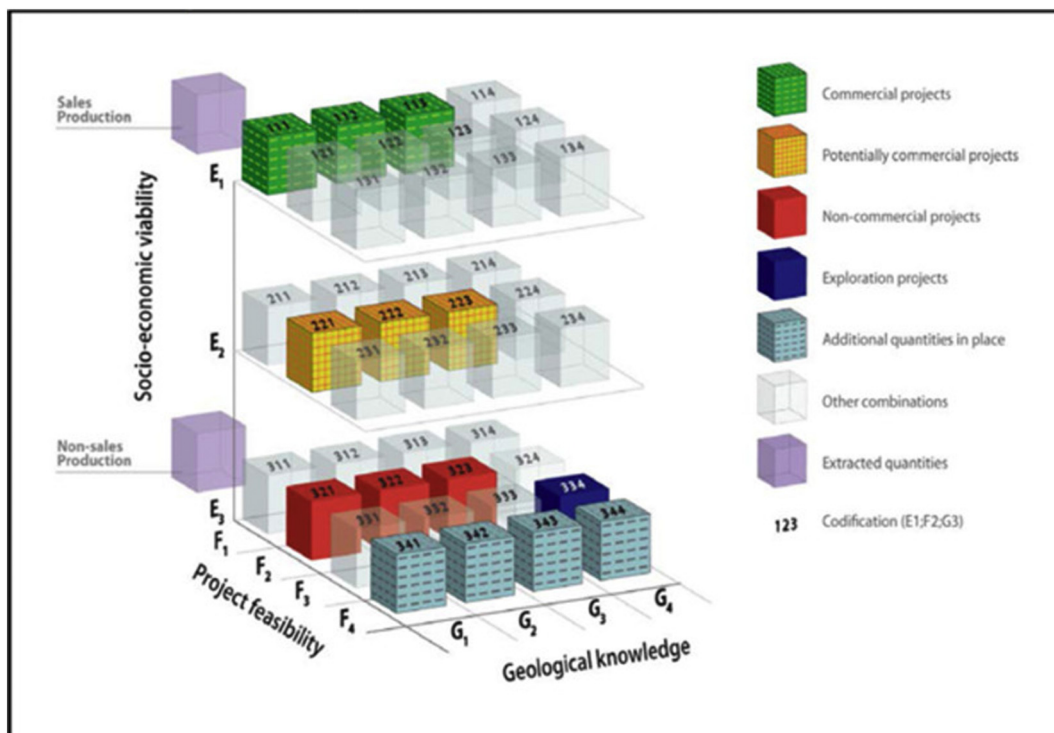

Fig. 9. Resource classification according to UNFC-2009 (UNECE, 2010).

(Fellner et al., 2015). One reason for this is that substance related data on APCr/FA tends to be collected for the purpose of landfilling (e.g. leaching contents) rather than for resource recovery (e.g. total contents), thus a lot of data already collected is of little use for the latter (Lederer et al., 2017c). Another reason is that substance concentrations and the mineralogy of APCr/FA are not only determined by the composition of the input material (MSW), but also by the incineration and APC technology (Fellner et al., 2015).

4.2. Project feasibility (y axis)

Project feasibility (y axis) encompasses a number of factors. An important factor for APCr/FA is the legal situation. According to present regulations, raw APCr/FA in cement clinker production would, for instance, be possible in Austria (where it is not practiced), but to a lesser extent in Switzerland, where environmental requirements are stricter (Lederer et al., 2017c). Another important factor is the stage of mining, which would be the equivalent of the technological readiness level (TRL) for APCr/FA secondary raw material recovery technologies. Of the technologies presented, only the utilization of APCr/FA in cement production (Section 3.3) and the FLUWA/FLUREC processes (Section 3.4) are practiced on a large scale, the former only in China and Taiwan, the latter in plants in Switzerland (FLUWA/FLUREC), Germany and the Czech Republic (FLUWA). All other technologies presented apart from the HALOSEP® plant being built in Denmark only exist on a pilot or even a laboratory scale.

4.3. Socio economic viability (z axis)

Socio economic viability also consists of many factors, and the most important are the economic and ecological costs of secondary raw material production as both influence the decision making and acceptance by societies. Not many studies exist for the first one. Fellner et al. (2015) investigated the economic viability of the FLUREC process in Europe and showed that depending on the incineration and APC technology, on the one hand, and the metal contents in waste, on the other, its application can be economically viable. The avoidance of landfill tax is another large driver, which means that policy makers can have great influence on the economic viability of recovery of secondary raw materials from APCr/FA. Huang et al. (2017) showed for the case of Taiwan that APCr/FA in cement production is associated with the lowest economic costs if compared to other APCr/FA disposal and recovery techniques, including landfilling, use in bricks and Zn recovery in the Waelz process. Despite these relatively clear results, Huber and Fellner (2018) point out that an economic evaluation must always be seen from at least two view points, namely the private companies' as well as the societies' perspectives. Initial estimations for the HALOSEP process, which will be published soon, suggest that the costs of this process will be 15-20% lower than conventional APCr/FA disposal in Denmark. For the other technologies, no data on the economic viability was found. While the main reason for that is their comparatively low to medium TRL, it can also be seen as a call to carry out more research on pilot and larger scale in this direction. Environmental impacts have been determined

for the utilization of APCr/FA in cement (Huang et al., 2017; Huber et al., 2017), the metal recovery by FLUREC and FLUWA (Boesch et al., 2014; Huber et al., 2018) and salt recycling (Johansson, 2017). Except for the utilization in cement in the case of Taiwan (Huang et al., 2017), all of these studies find the recovery technologies investigated to be of lower environmental impact than the disposal options currently practiced (Boesch et al., 2014; Huber et al., 2018; Johansson, 2017). It is now difficult to use the results of these studies for a comparison between the different APCr/FA technologies presented in Section 3 of this paper. However, another study by Huber et al. (2017) found that the FLUREC process performs much better in terms of environmental impact than its utilization in cement clinkers, mainly due to the emissions of Hg during clinker production. In addition to economic and environmental considerations, the role of APCr/FA as an anthropogenic resource can be included as an evaluation criterion in UNFC 2009 as not all secondary raw materials produced have the same strategic relevance for Europe (European Commission, 2017). One example that can be used to determine the strategic relevance is the contribution of a given secondary raw material produced from APCr/FA to the overall demand of this same raw material; another involves examining to what extent the secondary raw material production reduces the import dependency on the primary raw material substituted. Since in the EU 28, for instance, this import dependency is currently 55% for metals (Cd, Cu, Pb, Zn) and 3% for minerals (salts; calcites, silicates and clays), a recovery of metals seems to be of higher relevance than a recovery of minerals to meet a hypothetical objective of import independency (EUROSTAT, 2017).

4.4. Information requirements for the evaluation of APCr/FA as anthropogenic resource

The discussion of applying UNFC 2009 as an alternative to conventional evaluation and classification approaches in connection with the production of secondary raw materials from APCr/FA also highlights one of the weaknesses of this approach, namely the large amount of information required to perform such evaluation. However, this complexity better reflects the real world situation beyond solely considering environmental impacts or the economic cost benefits of a technology to produce a secondary raw material from APCr/FA. Table 5 gives some examples of what information might be required to thoroughly apply UNFC 2009 to the six case studies presented in Section 3.

From Table 5 it not only becomes clear that the information requirements for UNFC 2009 are high, but also that some of the information very much depends on national or even local contexts. One example is the utilization of APCr/FA in cement clinker production. Even though Huber and Fellner (2018) classify this resource use as highly viable and feasible, their evaluation results would be much different if carried out in a country specific evaluation for the case of Austria and neighboring Switzerland. There are several reasons for this assumption. The most important one is probably the fact that the legal requirements for the use of APCr/FA in cement are higher in Switzerland than in Austria, resulting in lower project feasibility (y axis) for cement use in Switzerland than in Austria. This underlines that the application of

Table 5
Examples of information required for a UNFC-2009 evaluation and classification of APCr/FA and their relevance for the different evaluation axis ("X" means directly relevant, "O" means indirectly relevant, and "-" means not relevant).

Information	Relevant for	x-axis	y-axis	z-axis
Waste incinerated	Grade/species of raw material, pollutants content	X	O	O
Incinerator technology	Grade/species of raw material, pollutants content	X	O	O
APC system	Grade/species of raw material, pollutants content, leaching agent available (FLUWA/FLUREC, Halosep)	X	O	O
Environmental laws	Use of secondary raw materials prohibited or not; legal requirements for production and use of secondary raw materials; landfilling/export ban of untreated APCr/FA	-	X	O
Raw material markets	Market for secondary raw material present or not (e.g. deicing salts only in colder climates; FLUWA/Halosep metal concentrate need metal smelters available; presence of a cement clinker plant)	-	O	X
Energy availability/costs	Processing of APCr/FA (e.g. evaporation of water from salt extraction)	-	O	X

UNFC 2009 requires not only adequate economic, legal and technological knowledge, but context specific local knowledge as well. For this reason, Lederer et al. (2017b) suggested that the whole process of evaluation and classification of anthropogenic resources such as APCr/FA related to the production of secondary raw materials should preferably be carried out by country experts rather than by external researchers or consultants.

5. Conclusions

European societies desire better management of APCr/FA, care that not only provides safe final disposal of this hazardous waste, but also recovers secondary raw materials from this anthropogenic resource. The article at hand presented six case studies to meet this additional objective of resource conservation. The first three of them are associated with the manufacturing of products, while the other three are related to the recovery of metals and salts. For contemporary European societies and their decision makers, the important question is now how to decide which management and recovery/recycling technology should be selected for its further development and application. The UNFC 2009 might be a useful evaluation and classification approach that can support this decision as it provides a multidimensional analysis of wastes as resources. However, to apply this approach, a lot of information, some of it highly context specific, must be collected and processed. As in the case of the McKelvey Box of the USGS or UNFC 2009, both of which were "borrowed" from natural resource extraction, the mining industry once again provides a good example of how to overcome this challenge. For the Minerals Yearbook and Minerals Commodity Summaries, the USGS Mineral Resources Program compiles information on natural resource deposits of metals and minerals all over the world (USGS, 2017). The information is provided by competent persons who are country experts that not only have good economic and technical expertise, but also context specific knowledge of the legal, socio economic and socio cultural situation in the countries they report from. Building up such a network of competent persons or institutes for the recovery of secondary raw materials from APCr/FA would be beneficial to make much better use of these anthropogenic resources and thereby achieving a more circular economy.

Acknowledgments

This article is based upon work from COST Action "Mining the European Anthroposphere" (CA15115), supported by COST (European Cooperation in Science and Technology), and the research project "Christian Doppler Laboratory for Anthropogenic Resources".

References

Alhadj-Mallah, M.M., Huang, Q., Cai, X., Chi, Y., Yan, J., 2015. Vitrification of municipal solid waste incineration fly ash using biomass ash as additives. *Environ. Technol.* 36, 654–660.

Amutha Rani, D., Boccacchini, A.R., Deegan, D., Cheeseman, C.R., 2008. Air pollution control residues from waste incineration: current UK situation and assessment of alternative technologies. *Waste Manag.* 28, 2279–2292.

Astrup, T., 2008. Management of APC residues from W-t-E Plants: an overview of management options and treatment methods. Working Group on Thermal Treatment of Waste, Second edition The International Solid Waste Association (ISWA), Copenhagen.

Astrup, T., Rosenblad, C., Trapp, S., Christensen, T.H., 2005. Chromium release from waste incineration air-pollution-control residues. *Environ. Sci. Technol.* 39, 3321–3329.

AWEL, Office for Waste Management, Environmental Protection Agency of Canton Zürich (AWEL Zürich), 2013. Stand der Technik für die Aufbereitung von Rauchgasreinigungsrückständen (RGR) aus Kehrlichtverbrennungsanlagen.

Bacocchi, R., Carnevale, E., Costa, G., Gavasci, R., Lombardi, L., Olivieri, T., Zanchi, L., Zingaretti, D., 2013. Performance of a biogas upgrading process based on alkali adsorption with regeneration using air pollution control residues. *Waste Manag.* 33, 2694–2705.

Belevi, H., Stämpfli, D.M., Baccini, P., 1992. Chemical behaviour of municipal solid waste incinerator bottom ash in monofills. *Waste Manag. Res.* 10, 153–167.

Belmonte, L.J., Ottosen, L.M., Kirkelund, G.M., Jensen, P.E., Vestbo, A.P., 2016. Screening of heavy metal containing waste types for use as raw material in Arctic clay-based

bricks. *Environ. Sci. Pollut. Res. Int.* (in press). <https://doi.org/10.1007/s11356-016-8040-z>.

Benassi, L., Franchi, F., Catina, D., Cioffi, F., Rodella, N., Borgese, L., Pasquali, M., Depero, L., Bontempi, E., 2015. Rice husk ash to stabilize heavy metals contained in municipal solid waste incineration fly ash: first results by applying new pre-treatment technology. *Materials* 8, 6868–6879.

Benassi, L., Pasquali, M., Zanoletti, A., Dalipi, R., Borgese, L., Depero, L.E., Vassura, I., Quina, M.J., Bontempi, E., 2016. Chemical stabilization of municipal solid waste incineration fly ash without any commercial chemicals: first pilot-plant scaling up. *ACS Sustain. Chem. Eng.* 4, 5561–5569.

Benassi, L., Dalipi, R., Consigli, V., Pasquali, M., Borgese, L., Depero, L.E., Clegg, F., Bingham, P.A., Bontempi, E., 2017. Integrated management of ash from industrial and domestic combustion: a new sustainable approach for reducing greenhouse gas emissions from energy conversion. *Environ. Sci. Pollut. Res.* 24, 14834–14846.

Besco, S., Brisotto, M., Gianoncelli, A., Depero, L.E., Bontempi, E., Lorenzetti, A., Modesti, M., 2013. Processing and properties of polypropylene-based composites containing inertized fly ash from municipal solid waste incineration. *J. Appl. Polym. Sci.* 130. <https://doi.org/10.1002/app.39692>.

Bilo, F., Moscoso, S., Borgese, L., DelBarba, M.V., Zacco, A., Bosio, A., Federici, S., Guarienti, M., Presta, M., Bontempi, E., Depero, L.E., 2015. Total reflection X-ray fluorescence spectroscopy to study Pb and Zn accumulation in zebrafish embryos. *X-Ray Spectrom.* 44, 124–128.

Binnemans, K., Jones, P.T., Blanpain, B., Van Gerven, T., Yang, Y., Walton, A., Buchert, M., 2013. Recycling of rare earths: a critical review. *J. Clean. Prod.* 51, 1–22.

BIO by Deloitte, 2015. Study to Assess the Impacts of Different Classification Approaches for Hazard Property "HP 14" on Selected Waste Streams – Final Report. Prepared for the European Commission (DG ENV) (in collaboration with INERIS).

Boesch, M.E., Vadenbo, C., Saner, D., Huter, C., Hellweg, S., 2014. An LCA model for waste incineration enhanced with new technologies for metal recovery and application to the case of Switzerland. *Waste Manag.* 34, 378–389.

Bogush, A.A., Stegemann, J.A., Wood, I., Roy, A., 2015. Element composition and mineralogical characterisation of air pollution control residue from UK energy-from-waste facilities. *Waste Manag.* 36, 119–129.

Bogush, A.A., Stegemann, J.A., Zhou, Q., Wang, Z., Zhang, W., Zhang, B., Zhang, T., Wei, W., 2017. Co-processing of energy-from-waste air pollution control residue in the cement kiln as a potential recycling option. 37th Cement and Concrete Science Conference, 11–12 September. University College London, UK.

Bontempi, E., 2017a. A new approach for evaluating the sustainability of raw materials substitution based on embodied energy and the CO2 footprint. *J. Clean. Prod.* 162, 162–169.

Bontempi, E., 2017b. Raw Materials Substitution Sustainability. Springer Briefs in Applied Sciences and Technology Springer ISBN 978-3-319-60830-3.

Bontempi, E., Zacco, A., Borgese, L., Gianoncelli, A., Ardesi, R., Depero, L.E., 2010. A new method for municipal solid waste incinerator (MSWI) fly ash inertization, based on colloidal silica. *J. Environ. Monit.* 12, 2093–2099.

Bosio, A., Rodella, N., Gianoncelli, A., Zacco, A., Borgese, L., Depero, L.E., Bingham, P.A., Bontempi, E., 2013. A new method to inertize incinerator toxic fly ash with silica from rice husk ash. *Environ. Chem. Lett.* 11, 329–333.

Bosio, A., Zacco, A., Borgese, L., Rodella, N., Colombi, P., Benassi, L., Depero, L.E., Bontempi, E., 2014. A sustainable technology for Pb and Zn stabilization based on the use of only waste materials: a green chemistry approach to avoid chemicals and promote CO2 sequestration. *Chem. Eng. J.* 253, 377–384.

Brannvall, E., Kumpiene, J., 2016. Fly ash in landfill top covers - a review. *Environ. Sci.-Proc. Imp.* 18, 11–21.

Bühler, A., Schlumberger, S., 2010. Schwermetalle aus der Flugasche zurückgewinnen «Saure Flugaschewäsche – FLUWA-Verfahren» ein zukunftsweisendes Verfahren in der Abfallverbrennung. KVA-Rückstände in der Schweiz - Der Rohstoff mit Mehrwert. Federal Office for the Environment (FOEN). pp. 185–192.

Cappai, G., Cara, S., Muntoni, A., Piredda, M., 2012. Application of accelerated carbonation on MSW combustion APC residues for metal immobilization and CO2 sequestration. *J. Hazard. Mater.* 207–208, 159–164.

CEMBUREAU, 2009. Sustainable Cement Production: Co-Processing of Alternative Fuels and Raw Materials in the European Cement Industry.

CEN, 2000. European Standard EN 197-1. Cement – Part 1: Composition, Specifications and Conformity Criteria for Common Cements. European Committee for Standardization (CEN), Brussels.

Chandler, A.J., Eighmy, T.T., Hartlen, J., Hjelmar, O., Kosson, D.S., Sawell, S.E., Van der Sloot, H.A., Vehlow, J. (Eds.), 1997. Municipal Solid Waste Incinerator Residues: Studies in Environmental Science. Vol. 67. Elsevier Science B.V., Amsterdam.

Chen, W., Chang, F., Shen, Y., Tsai, M., Ko, C., 2012. Removal of chloride from MSWI fly ash. *J. Hazard. Mater.* 237–238, 116–120.

Chen, Ch.-G., Sun, Ch.-J., Gau, S.-H., Wu, Ch.-W., Chen, Y.-L., 2013. The effect of the mechanical-chemical stabilization process for municipal solid waste incinerator fly ash on the chemical reactions in cement paste. *Waste Manag.* 33, 858–865.

Chen, Z., Lu, S., Mao, Q., Buekens, A., Chang, W., Wang, X., Yan, J., 2016. Suppressing heavy metal leaching through ball milling of fly ash. *Energies* 9 (524).

Colangelo, F., Messina, F., Cioffi, R., 2015. Recycling of MSWI fly ash by means of cementitious double step cold bonding pelletization: technological assessment for the production of lightweight artificial aggregates. *J. Hazard. Mater.* 299, 181–191.

Cyr, M., Idir, R., Escadeillas, G., 2012. Use of metakaolin to stabilize sewage sludge ash and municipal solid waste incineration fly ash in cement-based materials. *J. Hazard. Mater.* 243, 193–203.

De Boom, A., Degrez, M., 2015. Combining sieving and washing, a way to treat MSWI boiler fly ash. *Waste Manag.* 39, 179–188.

De Boom, A., Aubert, J.-E., Degrez, M., 2014. Carbonation of municipal solid waste incineration electrostatic precipitator fly ashes in solution. *Waste Manag. Res.* 32, 406–413.

- Deng, L., Xu, Q., Wu, H., 2016. Synthesis of zeolite-like material by hydrothermal and fusion methods using municipal solid waste fly ash. *Procedia Environ Sci* 31, 662–667.
- DEPA - Danish Environmental Protection Agency, 2016. *Electrodialytic Upgrading of MSWI APC Residue From Hazardous Waste to Secondary Resource*. Environmental project No.1884. Ministry of Environment and Food of Denmark, Environmental Protection Agency, Denmark.
- DIN, 2012. Flugasche für Beton – Teil 1: Definition, Anforderungen und Konformitätskriterien; Deutsche Fassung EN 450-1:2012 (Fly Ash for Concrete – Part 1: Definition, Specifications and Conformity Criteria; German Version EN 450-1:2012). Deutsches Institut für Normung (DIN), Berlin.
- EC, 2003. EU Council Decision 2003/33/EC of 19 December 2002 Establishing Criteria and Procedures for the Acceptance of Waste at Landfills Pursuant to Article 16 of and Annex II to Directive 1999/31/EC.
- Ecke, H., Menad, N., Lagerkvist, A., 2003. Carbonation of municipal solid waste incineration fly ash and the impact on metal mobility. *J. Environ. Eng.* 129, 435–440.
- Edwards, P., 2015. The rise and potential peak of cement demand in the urbanized world. *Global Cement Magazine*. <http://cornerstonemag.net/the-rise-and-potential-peak-of-cement-demand-in-the-urbanized-world/>.
- EIPPCB - European Integrated Pollution Prevention and Control Bureau, 2010. Reference Document on Best Available Techniques in the Cement, Lime and Magnesium Oxide Manufacturing Industries. European Commission, Joint Research Centre, Institute for Prospective Technological Studies Available at eippcb.jrc.ec.europa.eu/refer-ence/BREF/clm_bref_0510.pdf.
- European Commission, 2015. Study to develop a guidance document on the definition and classification of hazardous waste, report Reference:07.0201/2014/SI2.697025/EU/ENV.A.2. <http://ec.europa.eu/environment/waste/studies/pdf/definition%20classification.pdf>.
- European Commission, 2017. Communication from the Commission to the European Parliament, the Council, the European Economic and Social Committee and the Committee of the Regions on the 2017 List of Critical Raw Materials for the EU. COM(2017) 490 final. European Commission, Brussels (13.09.2017).
- EUROSTAT, 2017. Material Flow Accounts. Eurostat, Luxembourg.
- Fedje, K.K., Ekberg, C., Skarnemark, G., Steenari, B.-M., 2010. Removal of hazardous metals from MSW fly ash—an evaluation of ash leaching methods. *J. Hazard. Mater.* 173, 310–317.
- Fellner, J., Lederer, J., Purgar, A., Winterstetter, A., Rechberger, H., Winter, F., Laner, D., 2015. Evaluation of resource recovery from waste incineration residues - the case of zinc. *Waste Manag.* 37, 95–103.
- Fruergaard, T., Hyks, J., Astrup, T., 2010. Life-cycle assessment of selected management options for air pollution control residues from waste incineration. *Sci. Total Environ.* 408, 4672–4680.
- Funari, V., Braga, R., Bokhari, S.N., Dinelli, E., Meisel, T., 2015. Solid residues from Italian municipal solid waste incinerators: a source for "critical" raw materials. *Waste Manag.* 45, 206–216.
- Funari, V., Bokhari, S.N.H., Vigliotti, L., Meisel, T., Braga, R., 2016. The rare earth elements in municipal solid waste incinerators ash and promising tools for their prospecting. *J. Hazard. Mater.* 301, 471–479.
- Funari, V., Mäkinen, J., Salminen, J., Braga, R., Dinelli, E., Revitzer, H., 2017. Metal removal from municipal solid waste incineration fly ash: a comparison between chemical leaching and bioleaching. *Waste Manag.* 60, 397–406.
- Gao, X., Wang, W., Ye, T., Wang, F., Lan, Y., 2008. Utilization of washed MSWI fly ash as partial cement substitute with the addition of dithiocarbamic chelate. *J. Environ. Manag.* 88, 293–299.
- García-Lodeiro, I., Carcelen-Taboada, V., Fernandez-Jimenez, A., Palomo, A., 2016. Manufacture of hybrid cements with fly ash and bottom ash from a municipal solid waste incinerator. *Constr. Build. Mater.* 105, 218–226.
- Goh, Ch.-Ch., Show, K.-Y., Cheong, H.-K., 2003. Municipal solid waste fly ash as a blended cement material. *J. Mater. Civil Eng.* 15, 513–523.
- Goh, C.K., Valavan, S.E., Low, T.K., Tang, L.H., 2016. Effects of different surface modification and contents on municipal solid waste incineration fly ash/epoxy composites. *Waste Manag.* 58, 309–315.
- González, I., Vázquez, M.A., Romero-Baena, A.J., Barba-Brioso, C., 2017. Stabilization of fly ash using cementing bacteria. Assessment of cementation and trace element mobilization. *J. Hazard. Mater.* 321, 316–325.
- Guarienti, M., Gianoncelli, A., Bontempi, E., Moscoso, C.S., Borgese, L., Zizioli, D., Mitola, S., Depero, L.E., Presta, M., 2014. Biosafe inertization of municipal solid waste incinerator residues by COSMOS technology. *J. Hazard. Mater.* 279, 311–321.
- Gunning, P., Hills, C., Carey, P., 2012. Commercial production of accelerated carbonated aggregate from MSWI APCR. Proceedings of WASCON 2012, Proceedings of the 8th International conference on Sustainable management of waste and recycled materials in construction, Gothenburg, Sweden, 30 May–1 June.
- Guo, X., Shi, H., Wu, K., Ju, Z., Dick, W.A., 2016. Performance and risk assessment of alinite cement-based materials from municipal solid waste incineration fly ash (MSWIFA). *Mater. Struct.* 49, 2383–2391.
- Hartmann, S., Koval, L., Škrobánková, H., Matýšek, D., Winter, F., Purgar, A., 2015. Possibilities of municipal solid waste incinerator fly ash utilisation. *Waste Manag. Res.* 33, 740–747.
- Hasegawa, H., Rahman, I.M., Egawa, Y., Sawai, H., Begum, Z.A., Maki, T., Mizutani, S., 2014. Recovery of the rare metals from various waste ashes with the aid of temperature and ultrasound irradiation using chelants. *Water Air Soil Pollut.* 225 (2112) (13 pg). Hatch, G.P., 2012. Dynamics in the global market for rare earths. *Elements* 8, 341–346.
- Hennebert, P., van der Sloot, H.A., Rebischung, F., Weltens, R., Geerts, L., Hjelmar, O., 2014. Hazard property classification of waste according to the recent propositions of the EC using different methods. *Waste Manag.* 34, 1739–1751.
- Hjelmar, O., 2013. Washing of residues from municipal solid waste incinerators. In: Cossu, R., van der Sloot, H. (Eds.), *Sustainable Landfilling*. CISA Publishing, Italy, pp.402–415.
- Hjelmar, O., Birch, H., Hansen, J.B., 2001. The VKI process for treatment of APC residues from MSW incineration: Process development and optimisation in pilot scale. Pro-ceedings of the Second ISWA Seminar on Waste-To-Energy – State of the Art and Lat-est News, Malmö, Sweden, October 25–26.
- Hjelmar, O., Hansen, J.B., Birch, H., 2006. A one-stage treatment process for improving the leaching characteristics of APC residues from MSW incinerators. Proceedings of WASCON 2006, Sixth International Conference on the Environmental and Technical Implications of Construction with Alternative Materials – Science and Engineering of Recycling for Environmental Protection, Belgrade, Serbia & Montenegro, May 30–June 2.
- Hu, Y., Zhang, P., Li, J., Chen, D., 2015. Stabilization and separation of heavy metals in incineration fly ash during the hydrothermal treatment process. *J. Hazard. Mater.* 299, 149–157.
- Hu, H.-Y., Liu, H., Zhang, Q., Zhang, P.-A., Li, A.-J., Yao, H., Naruse, I., 2016. Sintering characteristics of CaO-rich municipal solid waste incineration fly ash through the addition of Si/Al-rich ash residues. *J. Mater. Cycles Waste Manag.* 18, 340–347.
- Huang, T.Y., Chiueh, P.T., 2015. Life cycle assessment of reusing fly ash from municipal solid waste incineration. *Procedia Eng.* 118, 984–991.
- Huang, T.Y., Chiueh, P.T., Lo, S.L., 2017. Life-cycle environmental and cost impacts of reusing fly ash. *Resour. Conserv. Recycl.* 123, 255–260.
- Huber, F., Fellner, J., 2018. Integration of LCA with monetary valuation into a resource classification framework: the case of MSWI fly ash. *Resour. Conserv. Recycl.* (Submitted). Huber, F., Blasenbauer, D., Mallow, O., Lederer, J., Winter, F., Fellner, J., 2016. Thermal co-treatment of combustible hazardous waste and waste incineration fly ash in a rotary kiln. *Waste Manag.* 58, 181–190.
- Huber, F., Lederer, J., Laner, D., Fellner, J., 2017. Comparative life cycle assessment of the utilisation of MSWI fly ash in cement production and metal recovery. Proceedings of the 16th International Waste Management and Landfill Symposium, 2nd-6th October 2017 Forte Village/Santa Margherita die Pula.
- Huber, F., Laner, D., Fellner, J., 2018. Comparative life cycle assessment of MSWI fly ash treatment and disposal. *Waste Manag.* 73, 392–403.
- Jiang, J.-G., Du, X.-J., Chen, M.-Z., Zhang, C., 2009. Continuous CO₂ capture and MSWI fly ash stabilization utilizing novel dynamic equipment. *Environ. Pollut.* 157 (11), 2933–2938.
- Jin, M., Zheng, Z., Sun, Y., Chen, L., Jin, Z., 2016. Resistance of metakaolin-MSWI fly ash based geopolymer to acid and alkaline environments. *J. Non-Cryst. Solids* 450, 116–122.
- Johansson, K., 2017. Livscykelanalys Av Behandlingsprocesser för Flygaska från avfallsförbränning [Life Cycle Assessment of Treatment Processes for Fly Ash from Municipal Solid Waste Incineration - A Comparison of the Ash2S Alt Process and Existing Treatment Methods]. Swedish University of Agricultural Sciences.
- Jordan, M.M., Montero, M.A., Rincon-Mora, B., Rincon, J.M., Sanfeliu, T., 2015. Rustic ceramic covering tiles obtained by recycling of marble residues and msw fly ash. *Fresenius Environ. Bull.* 24, 533–538.
- Kalmykova, Y., Karlfeldt Fedje, K., 2013. Phosphorus recovery from municipal solid waste incineration fly ash. *Waste Manag.* 33, 1403–1410.
- Kalmykova, Y., Palme, U., Yu, S., Fedje, K.K., 2015. Life cycle assessment of phosphorus sources from phosphate ore and urban sinks: sewage sludge and MSW incineration fly ash. *Int. J. Environ. Res.* 9, 133–140.
- Karlfeldt Fedje, K., Ekberg, C., Skarnemark, G., Pires, E., Steenari, B.-M., 2012. Initial studies of the recovery of Cu from MSWI fly ash leachates using solvent extraction. *Waste Manag. Res.* 30, 1072–1080.
- Keppert, M., Polozhiy, K., 2014. Residual strength of thermally loaded mortars with municipal solid waste incineration fly ash used as supplementary cementitious material. *Adv. Mater. Res.* 982, 114–118.
- Keppert, M., Pavlík, Z., Tydlitát, V., Volfová, P., Švarcová, S., Šyc, M., Černý, R., 2012. Properties of municipal solid waste incineration ashes with respect to their separation temperature. *Waste Manag. Res.* 30, 1041–1048.
- Kim, J., An, J., Nam, B.H., Tasneem, K.M., 2016. Investigation on the side effects of municipal solid waste incineration ashes when used as mineral addition in cement-based material. *Road Mater. Pavement Des.* 17, 1–20.
- Kirkelund, G.M., Magro, C., Guedes, P., Jensen, P.E., Ribeiro, A.B., Ottosen, L.M., 2015. Electrolytic removal of heavy metals and chloride from municipal solid waste incineration fly ash and air pollution control residue in suspension - test of a new two compartment experimental cell. *Electrochim. Acta* 181, 73–81.
- Kubonova, L., Langova, S., Nowak, B., Winter, F., 2013. Thermal and hydrometallurgical recovery methods of heavy metals from municipal solid waste fly ash. *Waste Manag.* 33, 2322–2327.
- Kynicky, J., Smith, M.P., Xu, C., 2012. Diversity of rare earth deposits: the key example of China. *Elements* 8, 361–367.
- Lam, C.H., Ip, A.W., Barford, J.P., McKay, G., 2010a. Use of incineration MSW ash: a review. *Sustainability* 2, 1943–1968.
- Lam, C.H., Barford, J.P., McKay, G., 2010b. Utilization of incineration waste ash residues in Portland cement clinker. *Chem. Eng. Trans.* 21, 757–762.
- Lassesson, H., Fedje, K.K., Steenari, B.-M., 2014. Leaching for recovery of copper from municipal solid waste incineration fly ash: influence of ash properties and metal speciation. *Waste Manag. Res.* 32, 755–762.
- Lederer, J., Laner, D., Fellner, J., 2014. A framework for the evaluation of anthropogenic resources: the case study of phosphorus stocks in Austria. *J. Clean. Prod.* 84, 368–381.
- Lederer, J., Bogush, A., Fellner, J., 2017a. The utilization of solid residues from municipal solid waste incineration in the cement industry: a review. 16th International Waste Management and Landfill Symposium, 2-6th October, Sardinia, Italy.
- Lederer, J., Syc, M., Bogush, A., Fellner, J., 2017b. A network approach towards a secondary raw material inventory for Europe applied to waste incineration residues. Proceedings of the 16th International Waste Management and Landfill Symposium, 2nd-6th October 2017, Forte Village/Santa Margherita die Pula.

- Lederer, J., Trinkel, V., Fellner, J., 2017c. Wide-scale utilization of MSWI fly ashes in cement production and its impact on average heavy metal contents in cements: the case of Austria. *Waste Manag.* 60, 247–258.
- Lee, J.C., Pandey, B.D., 2012. Bio-processing of solid wastes and secondary resources for metal extraction - a review. *Waste Manag.* 32, 3–18.
- Li, M.G., Sun, C.J., Gau, S.H., Chuang, C.J., 2010. Effects of wet ball milling on lead stabilization and particle size variation in municipal solid waste incinerator fly ash. *J. Hazard. Mater.* 174, 586–591.
- Li, X., Chen, Q., Zhou, Y., Tyrer, M., Yu, Y., 2014. Stabilization of heavy metals in MSWI fly ash using silica fume. *Waste Manag.* 34, 2494–2504.
- Li, X., Wang, L., Zhang, H., Li, J., 2016. Stabilization of MSWI fly ash using alkali-activated strontium carbonate waste residues. *Fresenius Environ. Bull.* 25, 3775–3780.
- Liao, W.-P., Yang, R., Kuo, W.-T., et al., 2014. The application of electrocoagulation for the conversion of MSWI fly ash into nonhazardous materials. *J. Environ. Manag.* 137, 157–162.
- Lin, K.-L., Lo, K.-W., Shie, J.-L., Tuan, B.L., Hwang, C.-L., Chang, Y.-M., 2016. Properties and microstructure of eco-cement produced from co-sintered washed fly ash and waste sludge. *Environ. Prog. Sustain. Energy* 35, 764–771.
- Lindberg, D., Molin, C., Hupa, M., 2015. Thermal treatment of solid residues from WtE units: a review. *Waste Manag.* 37, 82–94.
- Liu, J., Chen, J., Huang, L., 2015. Heavy metal removal from MSS fly ash by thermal and chlorination treatments. *Sci. Rep.* 5 (17270).
- Liu, S.-J., Guo, Y.-P., Yang, H.-Y., Wang, S., Ding, H., Qi, Y., 2016. Synthesis of a water-soluble thiourea-formaldehyde (WTF) resin and its application to immobilize the heavy metal in MSWI fly ash. *J. Environ. Manag.* 182, 328–334.
- Lorber, K.-E., Wruss, K., Sarc, R., Pomberger, R., 2015. Durch den Aufgabeort bedingte Immissionen beim Einsatz alternativer Roh- und Brennstoffe im Zementwerk. In: Thomé-Kozmiensky, K., Löschau, M. (Eds.), *Immissionschutz (Immissions Protection)*. TK Verlag, Neuruppin, pp. 241–262.
- Luan, J., Chai, M., Li, R., Yao, P., Khan, A.S., 2016. The mineral phase evolution behaviour in the production of glass-ceramics from municipal solid waste incineration fly ash by melting technology. *Environ. Technol.* 37, 1036–1044.
- Lundtorp, K., Jensen, D.L., Sørensen, M.A., Mosbæk, H., Christensen, T.H., 2003. On-site treatment and landfilling of MSWI air pollution control residues. *J. Hazard. Mater.* 97, 59–70.
- Madloul, N.A., Saidur, R., Hossain, M.S., Rahim, N.A., 2011. A critical review on energy use and savings in the cement industries. *Renew. Sust. Energ. Rev.* 15, 2042–2060.
- Margallo, M., Taddei, M. B., Hernandez-Pellon, A., Aldaco, R., Irabien, A., 2015. Environmental sustainability assessment of the management of municipal solid waste incineration residues: a review of the current situation. *Clean Techn. Environ. Policy* 17, 1333–1353.
- Meffre, A., Py, X., Olives, R., Bessada, C., Veron, E., Echegut, P., 2015. High-temperature sensible heat-based thermal energy storage materials made of vitrified MSWI fly ashes. *Waste Biomass Valoriz.* 6, 1003–1014.
- Meylan, G., Spoerri, A., 2014. Eco-efficiency assessment of options for metal recovery from incineration residues: a conceptual framework. *Waste Manag.* 34, 93–100.
- Morf, L.S., Gloor, R., Haag, O., Haupt, M., Skutan, S., Di Lorenzo, F., Boni, D., 2013. Precious metals and rare earth elements in municipal solid waste-sources and fate in a Swiss incineration plant. *Waste Manag.* 33, 634–644.
- Moriwaki, H., Yamamoto, H., 2013. Interactions of microorganisms with rare earth ions and their utilization for separation and environmental technology. *Appl. Microbiol. Biotechnol.* 97, 1–8.
- Müller, C., 2012. Use of cement in concrete according to European standard EN 206-1. *HBRC J.* 8, 1–7.
- Nomura, Y., Nakai, S., Hosomi, M., 2005. Elucidation of degradation mechanism of dioxins during mechanochemical treatment. *Environ. Sci. Technol.* 39, 3799–3804.
- Nomura, Y., Fujiwara, K., Takada, M., Nakai, S., Hosomi, M., 2008. Lead immobilization in mechanochemical fly ash recycling. *J. Mater. Cycles Waste Manag.* 10, 14–18.
- Okada, T., Tomikawa, H., 2016. Efficiencies of metal separation and recovery in ash-melting of municipal solid waste under non-oxidative atmospheres with different reducing abilities. *J. Environ. Manag.* 166, 147–155.
- Pan, J.R., Huang, C., Kuo, J.-J., Lin, S.-H., 2008. Recycling MSWI bottom and fly ash as raw materials for Portland cement. *Waste Manag.* 28, 1113–1118.
- Pandey, B.D., Natarajan, K.A., 2015. *Microbiology for Minerals, Metals, Materials and the Environment*. CRC Press.
- Pares Viader, R., Jensen, P.E., Ottosen, L.M., 2016. Electrodialytic remediation of municipal solid waste incineration residues using different membranes. *Chemosphere* 169, 62–68.
- Parlikar, U., Bundela, P.S., Baidya, C., Ghosh, S.K., Ghosh, S.K., 2016. Effect of variation in the chemical constituents of wastes on the co-processing performance of the cement kilns. *Procedia Environ Sci* 35, 506–512.
- Ponsot, I., Bernardo, E., Bontempi, E., Depero, L., Detsch, R., Chinnam, R.K., Boccaccini, A.R., 2015. Recycling of pre-stabilized municipal waste incinerator fly ash and soda-lime glass into sintered glass-ceramics. *J. Clean. Prod.* 89, 224–230.
- Purgar, A., Winter, F., Blasenbauer, D., Hartmann, S., Fellner, J., Rechberger, H., 2016. Main drivers for integrating zinc recovery from fly ashes into the Viennese waste incineration cluster. *Fuel Process. Technol.* 141, 243–248.
- Qian, G., Cao, Y., Chui, P., Tay, J., 2006. Utilization of MSWI fly ash for stabilization/solidification of industrial waste sludge. *J. Hazard. Mater.* (B129), 274–281.
- Qiu, Q., Jiang, X., Lv, G., Lu, S., Ni, M., 2016. Stabilization of heavy metals in municipal solid waste incineration fly ash in circulating fluidized bed by microwave-assisted hydro-thermal treatment with additives. *Energy Fuels* 30, 7588–7595.
- Quina, M.J., Santos, R.C., Bordado, J.C.M., Quinta-Ferreira, R.M., 2008a. Characterization of air pollution control residues produced in a municipal solid waste incinerator in Portugal. *J. Hazard. Mater.* 152, 853–869.
- Quina, M.J., Bordado, J.C.M., Quinta-Ferreira, R.M., 2008b. Treatment and use of air pollution control residues from msw incineration: an overview. *Waste Manag.* 28, 2097–2121.
- Quina, M.J., Bordado, J.C.M., Quinta-Ferreira, R.M., 2010. Chemical stabilization of air pollution control residues from municipal solid waste incineration. *J. Hazard. Mater.* 179, 382–392.
- Quina, M.J., Bordado, J.C., Quinta-Ferreira, R.M., 2014a. Stabilization/solidification of APC residues from MSW incineration with hydraulic binders and chemical additives. *J. Hazard. Mater.* 264, 107–116.
- Quina, M.J., Bordado, J.C.M., Quinta-Ferreira, R.M., 2014b. Recycling of air pollution control residues from municipal solid waste incineration into lightweight aggregates. *Waste Manag.* 34, 430–438.
- Quina, M.J., Almeida, M., Santos, R., Bordado, J.C.M., Quinta-Ferreira, R.M., 2014c. Compatibility analysis of municipal solid waste incineration residues and clay for producing lightweight aggregates. *Appl. Clay Sci.* 102, 71–80.
- Ramanathan, T., Ting, Y.-P., 2016. Alkaline bioleaching of municipal solid waste incineration fly ash by autochthonous extremophiles. *Chemosphere* 160, 54–61.
- Rasmussen, E., 2015. Co-Treatment of APC Residues and Scrubber Liquid from MSWI Plants by HALOSEP (in Danish with English Summary), Environmental Project Nr. 1648. Danish EPA (Miljøstyrelsen), Copenhagen.
- Rawlings, D.E., 2002. Heavy metal mining using microbes. *Annu. Rev. Microbiol.* 56, 65–91.
- Rémond, S., Pimienta, P., Bentz, D.P., 2002. Effects of the incorporation of municipal solid waste incineration fly ash in cement pastes and mortars: I. Experimental study. *Cem. Concr. Res.* 32, 303–311.
- Rodella, N., Bosio, A., Dalipi, R., Zacco, A., Borgese, L., Depero, L.E., Bontempi, E., 2017. Waste silica sources as heavy metal stabilizers for municipal solid waste incineration fly ash. *Arab. J. Chem.* 10, S3676–S3681.
- Saikia, N., Kato, Sh., Kojima, T., 2007. Production of cement clinkers from municipal solid waste incineration (MSWI) fly ash. *Waste Manag.* 27, 1178–1189.
- Schlumberger, S., Schuster, M., Ringmann, S., Koralewska, R., 2007. Recovery of high purity zinc from filter ash produced during the thermal treatment of waste and inerting of residual materials. *Waste Manag. Res.* 25, 547–555.
- Shi, H.-S., Kan, L.-L., 2009. Leaching behavior of heavy metals from municipal solid waste incineration (MSWI) fly ash used in concrete. *J. Hazard. Mater.* 164, 750–754.
- Shih, P.-H., Chang, J.-E., Chiang, L.-Ch., 2003. Replacement of raw mix in cement production by municipal solid waste incineration ash. *Cem. Concr. Res.* 33, 1831–1836.
- Srivastava, V.C., Mall, I.D., Mishra, I.M., 2006. Characterization of mesoporous rice husk ash (RHA) and adsorption kinetics of metal ions from aqueous solution onto RHA. *J. Hazard. Mater.* 134, 257–267.
- Stafford, F.N., Viquez, M.D., Labrincha, J., Hotza, D., 2015. Advances and challenges for the co-processing in Latin American cement industry. *Procedia. Mater. Sci.* 9, 571–577.
- Swiss Confederation, 2016. Verordnung über die Vermeidung und die Entsorgung von Abfällen (VVEA). pp. 1–46.
- Tang, J., Steenari, B.-M., 2015. Solvent extraction separation of copper and zinc from MSWI fly ash leachates. *Waste Manag.* 44, 147–154.
- Tang, J., Steenari, B.-M., 2016. Leaching optimization of municipal solid waste incineration ash for resource recovery: a case study of Cu, Zn, Pb and Cd. *Waste Manag.* 48, 315–322.
- Travar, I., Kihl, A., Kumpiene, J., 2015a. The release of As, Cr and Cu from contaminated soil stabilized with APC residues under landfill conditions. *J. Environ. Manag.* 151, 1–10.
- Travar, I., Kihl, A., Kumpiene, J., 2015b. Utilization of air pollution control residues for the stabilization/solidification of trace element contaminated soil. *Environ. Sci. Pollut. Res.* 22, 19101–19111.
- Tu, X., Yu, L., Yan, J., Cen, K., Chéron, B.G., 2010. Plasma vitrification of air pollution control residues from municipal solid-waste incineration. *IEEE Trans. Plasma Sci.* 38, 3319–3325.
- UNECE, 2010. United Nations Framework Classification for Fossil Energy and Mineral Resources 2009 (UNFC-2009). United Nations Economic Commission for Europe (UNECE), United Nations, New York, Geneva.
- USGS, 2017. Mineral Commodity Summaries 2017: U.S. Geological Survey. <https://doi.org/10.3133/70180197> (202 p).
- Valle-Zermeño, R., Formosa, J., Chimenos, J.M., Martínez, M., Fernández, A.I., 2013. Aggregate material formulated with MSWI bottom ash and APC fly ash for use as secondary building material. *Waste Manag.* 33, 621–627.
- Valle-Zermeño, R., Formosa, J., Prieto, M., Nadal, R., Niubó, M., Chimenos, J.M., 2014. Pilot-scale road subbase made with granular material formulated with MSWI bottom ash and stabilized APC fly ash: environmental impact assessment. *J. Hazard. Mater.* 266, 132–140.
- Van Oss, H.G., 2015. Mineral commodity summaries 2015. USGS, & U.S. Department of the Interior (USDI). minerals.usgs.gov/minerals/pubs/mcs/2015/mcs2015.pdf.
- Vehlow, J., Braun, H., Horch, K., Merz, A., Schneider, J., Stieglitz, L., Vogg, H., 1990. Semi-technical demonstration of the 3-R process. *Waste Manag. Res.* 8, 461–472.
- Wachter, A., Ionel, I., Wachter, R., Vargaa, L.A., Negrea, A., Minzatu, V., Muntean, C., Ciopec, M., 2016. Encapsulation of municipal solid waste incineration residues into coal fly ash rock matrix. *J. Environ. Protect. Ecol.* 17, 1037–1047.
- Wang, F.-H., Zhang, F., Chen, Y.-J., Gao, J., Zhao, B., 2015a. A comparative study on the heavy metal solidification/stabilization performance of four chemical solidifying agents in municipal solid waste incineration fly ash. *J. Hazard. Mater.* 300, 451–458.
- Wang, Y., Pan, Y., Zhang, L., Yue, Y., Zhou, J., Xu, Y., Qian, G., 2015b. Can washing-pretreatment eliminate the health risk of municipal solid waste incineration fly ash reuse? *Ecotoxicol. Environ. Saf.* 111, 177–184.
- Wang, L.L., Jamro, I.A., Chen, Q., Li, S., Luan, J., Yang, T., 2016. Immobilization of trace elements in municipal solid waste incinerator (MSWI) fly ash by producing calcium

- sulphoaluminate cement after carbonation and washing. *Waste Manag. Res.* 34, 184–194.
- WBCSD, 2005. The Cement Sustainability Initiative. World Business Council for Sustainable Development Progress Report, Switzerland.
- WBCSD, 2014. Guidelines for Co-processing Fuels and Raw Materials in Cement Manufacturing. World Business Council for Sustainable Development Progress Report, Cement Sustainability Initiative (CSI), Version 2.0, Switzerland.
- Weibel, G., 2017. Optimized Metal Recovery from Fly Ash from Municipal Solid Waste Incineration, PhD Thesis. Institute for Geological Sciences, University of Bern, Switzerland.
- Wilewska-Bien, M., Lundberg, M., Steenari, B.-M., Theliander, H., 2007. Treatment process for MSW combustion fly ash laboratory and pilot plant experiments. *Waste Manag.* 27, 1213–1224.
- Winterstetter, A., Laner, D., Rechberger, H., Fellner, J., 2016. Evaluation and classification of different types of anthropogenic resources: the cases of old landfills, obsolete computers and in-use wind turbines. *J. Clean. Prod.* 133, 599–615.
- Wu, K., Shi, H., Guo, X., 2011. Utilization of municipal solid waste incineration fly ash for sulfoaluminate cement clinker production. *Waste Manag.* 31, 2001–2008.
- Xie, F., Zhang, T.A., Dreisinger, D., Doyle, F., 2014. A critical review on solvent extraction of rare earths from aqueous solutions. *Miner. Eng.* 56, 10–28.
- Xue, Q., Li, J.-S., Wang, P., Liu, L., Li, Z.-Z., 2014. Removal of heavy metals from landfill leachate using municipal solid waste incineration fly ash as adsorbent. *Clean: Soil, Air, Water* 42, 1626–1631.
- Yang, R., Liao, W.-P., Lin, C.-Y., 2013. Feasibility of lead and copper recovery from MSWI fly ash by combining acid leaching and electrodeposition treatment. *Environ. Prog. Sustain. Energy* 32, 1074–1081.
- Ye, N., Chen, Y., Yang, J., Liang, S., Hu, Y., Xiao, B., Huang, Q., Shi, J., Hu, J., Wu, X., 2016. Co-disposal of MSWI fly ash and Bayer red mud using a one-part geopolymeric system. *J. Hazard. Mater.* 318, 70–78.
- Yu, J., Qiao, Y., Jin, L., Ma, C., Paterson, N., Sun, L., 2015. Removal of toxic and alkali/alkaline earth metals during co-thermal treatment of two types of MSWI fly ashes in China. *Waste Manag.* 46, 287–297.
- Zacco, A., Borgese, L., Gianoncelli, A., Struis, R.P., Depero, L.E., Bontempi, E., 2014. Review of fly ash inertisation treatments and recycling. *Environ. Chem. Lett.* 12, 153–175.
- Zhang, Y., Soleimanbeigi, A., Likos, W.J., Edil, T., 2016a. Geotechnical and leaching properties of municipal solid waste incineration fly ash for use as embankment fill material. *Transp. Res. Rec.* 2579, 70–78.
- Zhang, Z., Li, A., Wang, X., Zhang, L., 2016b. Stabilization/solidification of municipal solid waste incineration fly ash via co-sintering with waste-derived vitrified amorphous slag. *Waste Manag.* 56, 238–245.