



ALMA MATER STUDIORUM
UNIVERSITÀ DI BOLOGNA

ARCHIVIO ISTITUZIONALE
DELLA RICERCA

Alma Mater Studiorum Università di Bologna Archivio istituzionale della ricerca

Salt-Induced Deterioration on FRP-Brick Masonry Bond

This is the final peer-reviewed author's accepted manuscript (postprint) of the following publication:

Published Version:

Salt-Induced Deterioration on FRP-Brick Masonry Bond / Cristina Gentilini; Elisa Franzoni; Mattia Santandrea; Christian Carloni. - STAMPA. - 18:(2019), pp. 1914-1921. (Intervento presentato al convegno 11th International Conference on Structural Analysis of Historical Constructions (SAHC 2018) tenutosi a Cusco (Perù) nel 11-13 September 2018) [10.1007/978-3-319-99441-3_205].

Availability:

This version is available at: <https://hdl.handle.net/11585/648242> since: 2019-02-19

Published:

DOI: http://doi.org/10.1007/978-3-319-99441-3_205

Terms of use:

Some rights reserved. The terms and conditions for the reuse of this version of the manuscript are specified in the publishing policy. For all terms of use and more information see the publisher's website.

This item was downloaded from IRIS Università di Bologna (<https://cris.unibo.it/>).
When citing, please refer to the published version.

(Article begins on next page)

“This is a post-peer-review, pre-copyedit version of an article published in Structural Analysis of Historical Constructions. The final authenticated version is available online at: http://dx.doi.org/10.1007/978-3-319-99441-3_205”.

Link at the published version:

<https://www.springer.com/gp/book/9783319994406>

© 2019. This manuscript version is made available under the Creative Commons Attribution-NonCommercial-NoDerivs (CC BY-NC-ND) 4.0 International License

([Creative Commons Attribution Non-Commercial 4.0 International \(CC BY-NC\)](https://creativecommons.org/licenses/by-nc/4.0/))

Salt-induced deterioration on FRP-brick masonry bond

Cristina Gentilini¹, Elisa Franzoni², Mattia Santandrea³ and Christian Carloni⁴

Abstract. In the past decades, several studies have shown how fiber reinforced polymer (FRP) composites are an effective technique to strengthen unreinforced brick masonry structures. However, very little is known about their durability against environmental aggression such as salt attack and freeze-thaw cycles, or elevated moisture content. This paper presents an investigation on influence of salt attack on the stress transfer between the FRP composite and the masonry substrate. In fact, it is well known that, in certain conditions, soluble salts crystallize within the pores of materials, leading to crystallization pressures that may overcome their tensile strength. To investigate this effect, FRP-masonry joints were subjected to salt crystallization cycles according to a conditioning procedure designed by the authors. After conditioning, direct shear tests were conducted on the masonry joints to investigate the interfacial bond between the substrate and the composite. Materials characterization was carried out in order to correlate the results of the direct shear tests with the salt distribution within the specimens. For comparison, direct shear tests were conducted on FRP-masonry joints that were not subjected to any cycle and therefore used as control.

Keywords: Durability, salt attack, moisture, FRP, bond behavior, masonry.

1 Introduction

Masonry buildings, usually made of materials with poor mechanical properties, are susceptible to partial or total collapse when subjected to earthquake actions [1-6]. Consequently, strengthening interventions have been developed to retrofit unreinforced masonry structures. In recent years, composite materials have been a popular research subject in the civil engineering field, as they offer high structural performance with low impact on the original structural configuration, which makes them extremely attractive as a strengthening system for existing masonry buildings. Among the composites, FRPs, which consist of fibers of different kind embedded in and applied to the substrate by an organic matrix (typically epoxy resin), are the most well-known and used ones [7]. The use of epoxy resins is associated with some drawbacks such as low fire resistance, low compatibility with the substrate as well as low reversibility. Several studies have been conducted to investigate the structural behavior of masonry elements strengthened with FRP composites [8-10]. In particular, a state-of-the-art review on strengthening of concrete and masonry structures as well as timber and glass elements with steel reinforced polymers is given in [11]. However, the durability and long-term performance of these systems are not sufficiently investigated yet.

¹ Assistant Professor, Department of Architecture - DA, Bologna, Italy, cristina.gentilini@unibo.it

² Assistant Professor, Department of Civil, Chemical, Environmental and Materials Engineering - DICAM, Bologna, Italy, elisa.franzoni@unibo.it

³ PhD student, Department of Civil, Chemical, Environmental and Materials Engineering - DICAM, Bologna, Italy, mattia.santandrea3@unibo.it

⁴ Associate Professor, Department of Civil, Chemical, Environmental and Materials Engineering - DICAM, Bologna, Italy, christian.carloni@unibo.it

The present study discusses the results of an experimental campaign conducted on steel FRP-masonry joints. Specimens have been subjected to an accelerated weathering protocol designed by the authors [12,13], in which the specimens underwent cycles in saline solution or water, in order to assess whether salts and water could affect the steel FRP-masonry bond behavior. Single-lap shear tests have been employed to determine the bond behavior, while ion chromatography has been used to investigate the distribution of the salts within the specimens and interpret the results of the mechanical tests.

2 Materials and methods

2.1 Materials and masonry specimens

Solid fired-clay bricks and a natural hydraulic lime-based mortar (class M5 according to EN 998-2 [14]) were employed to manufacture the masonry blocks. Brick compressive strength (determined according to EN 772-1 [15]), elastic modulus, and tensile strength (determined according to EN 12390-6 [16]) resulted equal to 18.7 MPa (CoV = 2%), 6.2 GPa (CoV = 11.5%) and 1.6 MPa (CoV = 14.9%), respectively. Thirteen blocks of nominal dimensions equal to 125 mm (width) × 120 mm (depth) × 380 mm (length) were manufactured. After the blocks were cured for 28 days, the FRP strip was applied to one face of the blocks. The FRP strip consisted of a unidirectional fiber sheet made of ultra-high strength galvanized steel micro-cords and a bi-component epoxy resin with glass transition temperature $T_g > 40$ °C as per the manufacturer's data sheet [17]. No primer was employed to smooth the surface of the blocks prior to applying the resin. It should be noted that the steel fiber sheet employed for the FRP reinforced blocks had a mass density equal to 2000 g/m². In the remainder of the paper, this type of composite will be called SRP (steel-reinforced polymer). In addition, for the sake of brevity, the SRP-masonry joints will be referred to as SRP specimens. SRP specimens were left to cure at room conditions for one week.

A sketch of a SRP specimen is represented in Fig. 1.

2.2 Weathering protocol

Ten SRP specimens (5+5) were subjected to conditioning cycles in water or in saline solution. Their bond behavior after the cycles, was compared to that of three SRP specimens that were not subjected to any conditioning cycle by means of a direct shear test (labels SRP_REF). The artificial weathering protocol was designed by the authors [12] to simulate the conditions of masonry structures subjected to rising damp and salts, when microclimatic changes lead to salt crystallization.

In brief, each cycle consisted of two phases: a *wet* phase in which the specimens were partially immersed in the solution for 48 hours (solution head 20 mm, the face immersed was the one opposite to the face with the composite strip) and they became saturated by capillary rise; a *dry* phase in which the specimens were kept in a ventilated oven at 40 °C for 48 hours. All conditioned specimens were subjected to 6 cycles. It should be noted that before the artificial weathering was started, the lateral surface of the specimens was covered with

duct tape to limit evaporation from those sides and to promote a vertical flow of the solution and a concentrated accumulation of the salts on the top face of the specimens, where the composite was located.

It should be noted that the weathering protocol employed in the present experimental campaign differs from several points of view from the available standard tests on the resistance of porous materials to salt crystallization (see for example [18-20]). The standards suggest to use saline solutions with much higher concentrations and more aggressive cycles (for example, temperatures of about 100 °C are indicated in the drying phase). However, their purpose is to reach the failure of the materials under testing. In the present accelerated weathering procedure, the aim is not to reach a rupture of the SRP composite via highly aggressive salt crystallization cycles, but rather to achieve, in a relatively short period of time, concentrations of salts in the specimens that can be found in real historical buildings [21,22]. Additionally, it should be noted that it is not possible, according to the available standards, to provide a relationship between the number of cycles employed in any weathering protocols and the number of years of real exposure, due to the complex nature of the salt crystallization phenomenon.

The saline solution was obtained with sodium chloride, NaCl (4 wt%) and sodium sulfate decahydrate, $\text{Na}_2\text{SO}_4 \cdot 10\text{H}_2\text{O}$ (10 wt%). Specimens that underwent this wet phase are labeled SRP_(CHL+SUL).

Specimens that underwent the wet phase in distilled water are labeled SRP_H₂O.

Table 1 summarizes all labels and artificial weathering procedures.

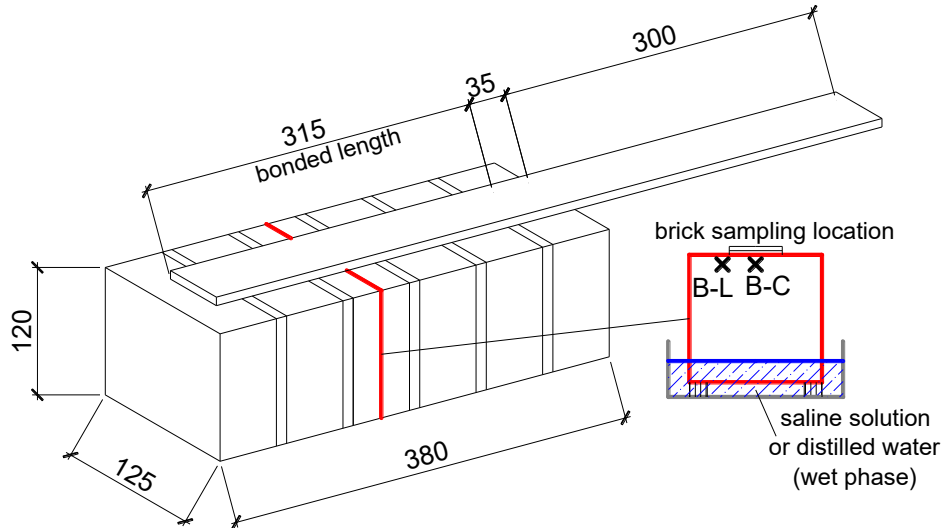

Figure 1. Final configuration and main dimensions (in mm) of the SRP specimens. Sampling locations in the brick (B-L and B-C) for materials characterization.

Table 1. Specimen labels and weathering protocol.

Label		Number of specimens	Composite type	Weathering protocol		
				Wet phase	Dry phase	Duration
SRP	SRP_REF	3	Steel fabric (mass density 2000 g/m ²) + bi-component epoxy resin	/	/	/
	SRP_(CHL+SUL)	5		48 h in an aqueous solution of NaCl and Na ₂ SO ₄ ·10H ₂ O	48 h at 40°C	6 cycles
	SRP_H ₂ O	5		48 h in distilled water	48 h at 40 °C	6 cycles

2.3 Direct shear test and materials characterization

At the end of the accelerated weathering protocol, direct shear tests were performed on all specimens. In Fig. 2a, a photo of an SRP_REF specimen at the beginning of the test is shown.

A complete description of the test setup is available in [12]. In brief, the main features of the experimental set-up are:

- A tensile force, P , was applied to the composite by the head of a 100 kN servo-hydraulic universal testing machine;
- The masonry block was restrained against movement between two steel plates connected by four bolted rods. The bottom plate was connected to the base of the testing machine.
- Two vertical LVDTs (linear variable displacement transformers) were employed to measure the relative displacement between the composite strip and the masonry surface at the beginning of the bonded area. The global slip g is the average of these two measurements;
- Two horizontal LVDTs were mounted on the base of the testing machine and reacted against the back face of the block, opposite to the face where the composite was applied, to monitor possible out-of-plane displacements of the masonry block during the test due to the eccentricity of the applied load [23];
- All the tests were performed under stroke-control at a constant loading rate equal to 3 $\mu\text{m/s}$ until failure.

After the direct shear tests were completed, brick and matrix fragments were collected from the specimens at the locations illustrated in Fig. 1, in order to determine their salt amounts. To obtain a representative result, two samples were extracted from two different SRP specimens for each group and sampling location. Ion chromatography (IC, Dionex ICS-1000, equipped with Ion Pac AG14A guard column and Ion Pac AS14A inorganic anion-exchange column kept at 30 °C; measuring cell temperature 35 °C) allowed to determine the soluble salts in terms of anions, after grinding to powder, extraction with deionized boiling water, and filtration by blue ribbon filter.



Figure 2. (a) Direct shear test set-up and (b) debonding with cohesive fracture of the support of SRP specimens.

3 Results and discussion

3.1 Direct shear test

Results of the direct shear tests in terms of average peak load P_{avg}^* , calculated as the mean value of the results for all specimens in each group, are collected in Table 2. Parameter Δ^* represents the percentage ratio in terms of P_{avg}^* for specimens that were subjected to the cycles with respect to REF ones.

SRP_REF specimens exhibited an average peak load of 10.36 kN and all the specimens showed debonding with cohesive fracture of the support, Fig. 2b.

After the cycles in water and in the saline solution, SRP_(CHL+SUL) and SRP_H2O specimens did not show significant differences compared with the SRP_REF specimens as reported in Table 2. This result can be attributed to the fact that salts crystallized mainly near the surface of the brick on the two sides of the composite rather than beneath it, since the epoxy resin stopped the capillary flow and evaporation of the solution. This aspect is confirmed by means of the IC (see Section 3.2).

Table 2. Direct shear test results. Coefficient of variation (CoV) within parentheses.

Specimen	P_{avg}^* [kN]	Δ^* [%]
SRP_REF	10.36 (13.1)	
SRP_(CHL+SUL)	8.97 (5.7)	-13.5
SRP_H2O	9.49 (7.0)	-8.5

3.2 Materials characterization

In Table 3, the results obtained from the IC are collected. Small amounts of salts in the bricks were found in SRP_REF and SRP_H2O, due to their presence in the materials used to construct the masonry blocks. As expected, an increase of the salt content (both chloride and sulfate) in the specimens cycled in saline solution was observed. The epoxy resin prevented the transport and evaporation of the solution in the central part of

the specimen (location B-C in Fig. 1). Thus, the increase in the amount of salts was more pronounced on the side of the composite (location B-L in Fig. 1), as the capillary flow was deviated towards the most permeable zones (i.e., the uncovered brick portions). Since the failure mode involved the bricks beneath the composite, and in that position (location B-C in Figure 1) the increase of salts after the cycles was small, this explains the results of the mechanical tests: in fact, SRP_(CHL+SUL) and SRP_H₂O specimens showed similar values of the peak load on average when compared with reference specimens (SRP_REF).

Table 3. Salt content of samples extracted from SRP specimens.

Samples	Sampling locations (as in Fig. 1)	Chloride (Cl ⁻ , wt%)	Sulfate (SO ₄ ²⁻ , wt%)
SRP_REF	B-L	0.050%	0.175%
	B-C	0.030%	0.030%
SRP_(CHL+SUL)	B-L	1.001%	0.993%
	B-C	0.680%	0.490%
SRP_H ₂ O	B-L	0.050%	0.092%
	B-C	0.033%	0.033%

4 Conclusions

This work investigated the effects of weathering cycles in water or saline solutions on the bond behavior between FRP composite and a brick masonry block.

The main results of the present study are summarized below:

- All SRP specimens showed a failure mode characterized by debonding with cohesive fracture of the support;
- After cycles in distilled water SRP specimens exhibited a negligible decrease in bond capacity;
- After cycles, salts tend to accumulate on the sides of the composite, hence they did not significantly affect the bond capacity;
- As shown by IC, the number of cycles considered in the present study leads to a realistic accumulation of salts in the material pores, i.e. similar to the quantities that can be found in real historical buildings. Reinforced specimens subjected to greater number of cycles are currently under investigation.

5 Acknowledgments

The experimental work discussed in this paper was conducted at the University of Bologna. Technicians of the laboratory LISG, CIRI, and LASTM are gratefully acknowledged for their help during the preparation of the specimens and the execution of the tests. The authors would like to express their appreciation to Kerakoll S.p.A. (Sassuolo, Italy) for providing the composite materials. Francesca Berardi is gratefully acknowledged for her support during the experimental campaign. Financial support by the Italian Ministry of Education, Universities and Research MIUR is gratefully acknowledged (PRIN2015: "Advanced mechanical modeling of new materials and structures for the solution of 2020 Horizon challenges", prot. 2015JW9NJT 018).

6 References

- [1] Mordanova, A., De Santis, S., De Felice, G. State-of-the-art review of out-of-plane strengthening of masonry walls with mortar-based composites (2016) *Structural Analysis of Historical Constructions: Anamnesis, diagnosis, therapy, controls - Proceedings of the 10th International Conference on Structural Analysis of Historical Constructions, SAHC 2016*, 337-343.
- [2] Valluzzi MR, Modena C, de Felice G. (2014) Current practice and open issues in strengthening historical buildings with composites. *Mater Struct* 47:1971-1985.
- [3] Gentilini C, D'Altri AM, Amato M, Zanotti P, Favaro F, de Miranda S. (2017) Salt attack effects on the shear behavior of masonry: Preliminary results of an experimental campaign. *Key Eng Mater* 747:512-517.
- [4] D'Altri AM, Castellazzi G, de Miranda S, Tralli A. (2017) Seismic-induced damage in historical masonry vaults: A case-study in the 2012 Emilia earthquake-stricken area. *J Build Eng* 13:224-243.
- [5] Franzoni E, Gentilini C, Graziani G, Bandini S. (2015) Compressive behaviour of brick masonry triplets in wet and dry conditions. *Constr Build Mater* 82:45-52.
- [6] Xu H, Wu H, Gentilini C, Su Q, Zhao S. (2017) Experimental study on seismic failure modes of confined masonry structures with different enhancements. *Key Eng Mater* 747:594-603.
- [7] Carloni C, Casacci S, de Miranda S, Di Tommaso A, Gentilini C, Ubertini F. (2015) Debonding between FRP and underlying masonry: First results of a 3D finite element model. *Key Eng Mater* 624:437-443.
- [8] Casacci S, Di Tommaso A, Gentilini C. (2015) Crack propagation in compression and mounted arrestors. *Key Eng Mater* 624:595-602.
- [9] Faella C, Camorani G, Martinelli E, Paciello SO, Perri F. (2012) Bond behaviour of FRP strips glued on masonry: Experimental investigation and empirical formulation. *Constr Build Mater* 31:353-363.
- [10] Papanicolaou CG, Triantafillou TC, Papathanasiou M, Karlos K. (2008) Textile reinforced mortar (TRM) versus FRP as strengthening material of URM walls: Out-of-plane cyclic loading. *Mater Struct* 41:143-157.
- [11] De Santis, S., de Felice, G., Napoli, A., Realfonzo, R. (2016) Strengthening of structures with Steel Reinforced Polymers: A state-of-the-art review. *Compos Part B: Eng* 104:87-110.
- [12] Franzoni E, Gentilini C, Santandrea M, Zanotto S, Carloni C. (2017) Durability of steel FRCM-masonry joints: effect of water and salt crystallization. *Mater Struct* 50, art. no. 201.
- [13] Franzoni E, Gentilini C, Graziani G, Bandini S (2014) Towards the assessment of the shear behaviour of masonry in on-site conditions: A study on dry and salt/water conditioned brick masonry triplets. *Constr Build Mater* 65:405-416.
- [14] EN 998-2 Specification for mortar for masonry - Part 2: Masonry mortar, 2016
- [15] EN 772-1 Methods of test for masonry units - Part 1: Determination of compressive strength, 2015.
- [16] EN 12390-6: Testing hardened concrete. Tensile splitting strength of test specimens, 2009.
- [17] Kerakoll 2013. Technical data sheet GeoLite Gel.<http://products.kerakoll.com/gestione/immagini/prodotti/00750geolite%20gel2013.pdf>
- [18] EN 12370 (1999) Natural stone test methods - Determination of resistance to salt crystallization.
- [19] RILEM TC 127-MS MS-A.1 (1998) Determination of the resistance of wallettes against sulphates and chlorides. *Mater Struct* 31:2-9.
- [20] RILEM TC 127-MS MS-A.2 (1998) Unidirectional salt crystallization test for masonry units. *Mater Struct* 31:10-11.
- [21] Sandrolini F, Franzoni E, Cuppini G, Caggiati L. (2007) Materials decay and environmental attack in the Pio Palace at Carpi: a holistic approach for historical architectural surfaces conservation. *Build Environ* 42:1966-1974.
- [22] Sandrolini F, Franzoni E. (2010) Characterization procedure for ancient mortars' restoration: the plasters of the Cavallerizza courtyard in the Ducal Palace in Mantua (Italy). *Mater Characterization* 61:97-104.
- [23] D'Antino T, Sneed LH, Carloni C, Pellegrino C. (2016) Effect of the inherent eccentricity in single-lap direct-shear tests of PBO FRCM-concrete joints. *Compos Struct* 142:117-129.