



ALMA MATER STUDIORUM
UNIVERSITÀ DI BOLOGNA

ARCHIVIO ISTITUZIONALE
DELLA RICERCA

Alma Mater Studiorum Università di Bologna Archivio istituzionale della ricerca

Efficiency improvement on a cruise ship: Load allocation optimization

This is the final peer-reviewed author's accepted manuscript (postprint) of the following publication:

Published Version:

Ancona, M., Baldi, F., Bianchi, M., Branchini, L., Melino, F., Peretto, A., et al. (2018). Efficiency improvement on a cruise ship: Load allocation optimization. *ENERGY CONVERSION AND MANAGEMENT*, 164(5), 42-58 [10.1016/j.enconman.2018.02.080].

Availability:

This version is available at: <https://hdl.handle.net/11585/664663> since: 2020-02-27

Published:

DOI: <http://doi.org/10.1016/j.enconman.2018.02.080>

Terms of use:

Some rights reserved. The terms and conditions for the reuse of this version of the manuscript are specified in the publishing policy. For all terms of use and more information see the publisher's website.

This item was downloaded from IRIS Università di Bologna (<https://cris.unibo.it/>).
When citing, please refer to the published version.

(Article begins on next page)

This is the final peer-reviewed accepted manuscript of:

Maria Alessandra Ancona, Francesco Baldi, Michele Bianchi, Lisa Branchini,
Francesco Melino, Antonio Peretto, Jessica Rosati

Efficiency Improvement On a Cruise Ship: Load Allocation Optimization,

Energy Conversion and Management, Volume 164, 2018, p. 42-58

The final published version is available online at:

<https://doi.org/10.1016/j.enconman.2018.02.080>

© 2018. This manuscript version is made available under the Creative Commons Attribution-NonCommercial-NoDerivs (CC BY-NC-ND) 4.0 International License (<http://creativecommons.org/licenses/by-nc-nd/4.0/>)

Efficiency Improvement On a Cruise Ship: Load Allocation Optimization

M. A. Ancona^a, F. Baldi^b, M. Bianchi^c, L. Branchini^a, F. Melino^c, A. Peretto^c, J. Rosati^{c,*}

^a CIRI-EA - Alma Mater Studiorum, via Angherà, 22, 47900 Rimini

^b Department of Shipping and Marine Technology – Chalmers University of Technology, 41276 Gothenburg, Sweden

^c Department of Industrial Engineering – DIN – Alma Mater Studiorum, viale del Risorgimento 2, 40136, Bologna

*corresponding author: e-mail: jessica.rosati3@unibo.it, phone: +39-051-2093320

ABSTRACT

Last years have been characterized by a worldwide increasing attention towards the reduction of fuel consumption and carbon dioxide emissions. Several industrial fields, as well as the civil and residential sector, have introduced innovative approaches for the design and the operation of energy systems. These actions are aimed to reach higher values of energy conversion efficiency, also including an increase in the use of renewable resources. In this context, especially in the sector of cruise ships, further efforts are required to improve the energy efficiency of the employed energy systems. The aim of this paper is to propose an optimization framework based on genetic algorithms in order to maximize the energy efficiency and minimize both the fuel consumption and the thermal energy dissipation, by optimizing the load allocation of the ship energy systems. To this purpose, different strategies for the energy systems on board of an existing cruise ship are proposed and analyzed. In particular, two main engines configurations have been defined: standard (current logic of operation maintained) and hybrid configuration. For each proposed strategy – being the ship a particular and interesting application of isolated energy grid (*i.e.* a grid without connections with electric and fuel national grids) – an in-house-developed software has been adapted and applied to optimize the load allocation of the various energy systems. Furthermore, an economic and environmental analysis has been carried out, in order to point out the benefits – or the eventual limits – related to the proposed solutions. The considered approach is based on the concept of introducing economically and structurally suitable modifications to the current cruise energy systems configuration, in order to reach the goal of increasing the energy efficiency. The carried out analysis shows that the hybrid strategies allow to reach the best results in terms of energy (fuel consumption and heat dissipation reduction), economic and environmental points of view.

Keywords: Energy Efficiency Increase; Energy Systems Load Optimization; Genetic Algorithm; Optimization Method; Shipping Energy Efficiency; Thermal Storage.

NOMENCLATURE

Symbols

C	cost [€]
CF_i	cash flow [€]
COP	coefficient of performance [-]
E	energy [kWh or MWh]
EER	energy efficiency ratio [-]
h	hours [h]
I_0	initial investment cost [€]
L	load [-]
n	number of units [-]
N	number of years [year]
P	power [kW]
r	discount rate [-]
T	temperature [°C or K]

Greek Symbols

η	efficiency [-]
μ	cost of maintenance [€/kW]
ξ	cost of electricity [€/kW or €/kWh]

Subscripts and Superscripts

DES	design
$disp$	dispersed

55	<i>E</i>	electricity
56	<i>EL</i>	electrical
57	<i>eq</i>	equivalent
58	<i>F</i>	fictitious
59	<i>FR</i>	cooling
60	<i>fuel</i>	fuel
61	<i>m</i>	mechanical
62	<i>M</i>	maintenance
63	<i>ST</i>	storage
64	<i>TH</i>	thermal
65	<i>tot</i>	total
66	λ	fuel
67		
68	<i>Acronyms</i>	
69	<i>AB</i>	auxiliary boilers
70	<i>AC</i>	absorption boilers
71	<i>BC</i>	base case
72	<i>CC</i>	compression chiller
73	<i>CHP</i>	combined heat and power
74	<i>CO</i>	carbon oxide
75	<i>CO₂</i>	carbon dioxide
76	<i>EGO</i>	energy grid optimizer
77	<i>ES</i>	electrical storage
78	<i>FF</i>	fitness function
79	<i>FT</i>	fuel tank
80	<i>HP</i>	heat pumps
81	<i>HY</i>	hybrid
82	<i>HY-S</i>	hybrid with storage
83	<i>HY-S-AC</i>	hybrid with storage and absorption chiller
84	<i>IMO</i>	international maritime organization
85	<i>NM VOC</i>	non-methane volatile organic compound
86	<i>NO_x</i>	nitrogen oxides
87	<i>NPV</i>	net present value
88	<i>OL</i>	optimized load
89	<i>OL-S</i>	optimized load with storage
90	<i>ORC</i>	organic Rankine cycle
91	<i>PM</i>	prime mover
92	<i>PMs</i>	particulate matters
93	<i>RG_e</i>	renewable electrical generator
94	<i>RG_t</i>	renewable thermal generator
95	<i>SO_x</i>	sulphur oxides
96	<i>TS</i>	thermal storage
97		

98 1. INTRODUCTION

99 1.1 Background

100 The development of new strategies to improve energy efficiency is one of the major challenges that world has to face today.
 101 Indeed, energy efficiency increase is playing a key role relating to the sustainable future planning [1-3].

102 One of the main reasons why research increasingly focuses on this topic lies into the global warming problem, primarily
 103 generated by greenhouse gas emissions, especially CO₂, as output of fossil fuels combustion [4-5]. This issue has been
 104 increasingly considered as fundamental in different fields, i.e. industrial, civil and domestic sectors. However, only in the last
 105 years the legislation in the transport sector and particularly in the maritime transport, where the contribution to greenhouse
 106 gases emission cannot be neglected, has been rearranged.

107 Shipping industry seems to play a minor role in regard to global anthropogenic CO₂ emissions, since it represents only the 3 %
 108 of the whole emissions, as of 2012 [1]. In fact, as it can be noted from **Figure 1** [6], that shows the CO₂ emissions from fuel
 109 combustion by different sector, the shipping sector contribution is equal to 3.3 % (including the international shipping and the
 110 domestic shipping and fishing).

111 However, relating to the shipping industry, it has to be considered that more than 40 % of the total shipping costs is attributed
 112 to fuel consumption [7]. Moreover, despite of its current low contribution, many predictions indicate for the next future an

113 increase in shipping volumes (which means, obviously, emissions increase) [8]. As a consequence, energy efficiency
114 management and control are fundamental aspects to account for fuel costs savings and CO₂ emissions reduction.
115 In this scenario both national and international energy policies increasingly focus on new solutions for energy systems
116 optimization and efficiency maximization. Recently, the *International Maritime Organization* introduced relevant regulations
117 and is continuously improving the standards of ship energy saving and emissions reduction [9-10]. With regard to this goal,
118 even the European Union is starting actions to achieve a reduction on transport's carbon emissions of 60 % by 2050. In
119 particular, focusing on the European scenario, the goal is a reduction of CO₂ emissions ranging from 40 % up to 50 % [11].

120 1.2 Energy efficiency in shipping

121 In order to achieve the previous goals, the shipping sector has developed new approaches to reduce the fuel consumption.
122 Some actions [12-17] relate to the ship operation, such as: (i) adapting routes in order to avoid conditions of bad weather, so
123 reducing the negative impact of high waves and strong wind on ship fuel consumption, (ii) maximizing the transported cargo
124 while reducing the length of ballast legs and (iii) improving trim and draft settings, together with the optimization of the
125 schedules and the practices for hull and propeller polishing, leading to reduced ship resistance for a given speed, etc.

126 Other actions [18-24] are related to new technical solutions with the purpose of improving the performance of on board
127 specific systems, such as the engines, the propeller, the hull, etc. In the last years, some other strategies for the emissions
128 control have been developed. Some alternatives, for example, act on the energy efficiency improvement by decreasing the time
129 of port stay. Another strategy, instead, consists in navigation speed regulation: studies show that the fuel consumption can be
130 reduced by determining the optimal engine speed, with an achievable reduction of about the 19 % with respect to the typical
131 fuel consumption per distance unit [18-24].

132 Some researchers focus on waste heat recovery. A valid technique consists in the application of energy storage devices for
133 engines heat recovering [27-28]. In particular, thermal storage can be seen as a promising solution for the energy efficiency
134 increase in marine transport field. The implementation in the shipping field of this simple solution (and/or other more complex
135 thermal storage solutions), therefore, enables the achievement of benefits, in terms of primary energy saving (through an
136 optimal use of resources), costs reduction (fuel consumption reduction) and environmental impact (through a reduction of
137 greenhouse gases). Moreover, the adoption of a fuel cell in addition to an energy storage device has been studied in [29].
138 Another approach is the adoption of an absorption refrigerator [30] to recover the thermal dissipation from the engines; finally,
139 the heat recovery can be realized considering the integration of marine diesel engines with an organic Rankine cycle (ORC)
140 system [31-33].

141 Different studies have been conducted as it regards the vessels' power management. To this purpose, some researchers [35]
142 have proposed a dynamic load management method which takes into account the equality and inequality constraints of a
143 certain system. Another study [36], instead, pointed out a three stages method, based on the operational cost minimization, to
144 find out an optimal power management solution and to limit the greenhouse gas emissions without changing the technical and
145 operational constraints. In [37-40] further methods have been proposed to model the power plant of an isolated system and to
146 find out an optimal load allocation of the vessel's components.

147 1.3 Aim

148 In this context, this paper proposes the use of an optimization framework based on genetic algorithms in order to optimize the
149 operations of ship energy systems, maximizing the energy efficiency and minimizing the fuel consumption. Compared to
150 previous efforts in the literature, the proposed approach has two main advantages: compared to a Mixed Integer Linear
151 Approach (MILP) (e.g. [41-43]), it retains the influences of nonlinear phenomena, and particularly of energy systems
152 efficiencies. Compared to traditional Mixed Integer Nonlinear approaches (MINLP) (e.g. [37]), it is more robust against the
153 risk of falling into local optima and less computational intensive. The combination of these two advantages allows to treat
154 problems of high complexity, as the optimization of ship energy systems, particularly when energy storage is included,
155 creating a strong coupling among the optimization parameters.

156 The use of genetic algorithms for the optimal load allocation of ship energy systems, with particular reference to electric and
157 thermal energy storage, has not been proposed before in the existing scientific literature (as for the best Authors knowledge)
158 and it constitutes the main element of novelty of this work.

159 The paper is structured as follows: in Section 2 the current configuration and the energy needs of the considered ship is
160 described; in Section 3 the calculation model used for the simulations is presented; in Section 4 the hypothesis and assumptions
161 are listed and, finally, in Section 5 the results of the simulations are presented and discussed.

162

163 2. CASE STUDY

164 The case study analyzed in the paper is a cruise ship operating in the Baltic Sea between Stockholm (in Swedish mainland) and
165 Mariehamn (in the Åland islands). The vessel is 177 meters long and about 28 meters wide with a design speed equal to 21
166 knots. Because of its capacity – up to 1'800 passengers – the vessel can be considered a medium size cruise ship. The ship is
167 equipped with restaurants, clubs and bars, as well as saunas and pools.

168 The ship makes the same daily route during the whole year (365 days/year) as shown in **Figure 2**. On the basis of its route and
169 according to the available information, the ship operational early profile can be divided among (i) sea going, (ii) port stay or
170 sea stay and (iii) maneuvering, as presented in **Figure 3**. From the figure, it can be noted that the port and sea stay operation
171 represents around one third of the total operational profile.
172

173 2.1 Energy Demand

174 The energy demand of the considered ship consists of (i) mechanical energy (for propulsion), (ii) electrical energy (for
175 lighting, cold appliance, hot appliance, auxiliary systems, etc.), (iii) thermal energy (mainly for space heating and hot water
176 production) and (iv) cooling energy (only during the summer period).

177 The vessel typical operational profile is always the same: the departure from Stockholm is scheduled around 6:00 PM; the ship
178 reaches the open sea where it stops for few hours during the night before reaching Mariehamn port early in the morning. Then
179 the ship leaves Mariehamn around 9:00 AM to go back to Stockholm where the arrivals are scheduled around 4:00 PM.

180 Thus, the mechanical energy demand is almost the same every day, while – since the travel's conditions (i.e. weather
181 condition) change – the thermal and cooling energy requests are different depending on the considered season.

182 The characterization of the energy needs of the ship could be done according to the operational modes taking into account the
183 following considerations:

- 184 • when the cruise ship is at the harbor (*port stay*) or laying in open sea (*sea stay*) the demand consists of electrical and
185 thermal energy (and cooling energy during the summer period) in order to guarantee the services of the ship for the
186 boarding and alighting of passengers (*port stay*) and for their comfort on board (*sea stay*);
- 187 • during the sailing (*sea going*) the demand reaches its maximum values in terms of mechanical demand;
- 188 • when the ship enters or leaves the port (*maneuvering*) the mechanical demand is intermediate between the one of sea
189 going and the one corresponding to *port stay* or *sea stay*.
- 190 • the electrical and thermal (for space heating and/or hot water production) demands are not influenced by the operational
191 profiles of the cruise.

192 The aforementioned considerations, together with an experimental data collection made on board [37], allow to estimate the
193 hourly load profile curves of mechanical, thermal, electrical and cooling power for typical days during winter, summer and
194 spring/fall, as presented in **Figure 4**. More details about the elaboration of these curves can be found in [37].

195 Relating to the duration of each season, according to the average monthly temperatures in Sweden [44], the following
196 assumptions can be made:

- 197 - winter: 182 days (since January the 1st to April the 15th and since October the 16th to December the 31st);
- 198 - summer: 62 days (since July the 1st to August the 31st)
- 199 - spring/fall: 121 days (since April the 16th to June the 30st and since September the 1st to October the 15th).

200 From **Figure 4** it can be observed that the mechanical power demand for propulsion is the same for each season as the
201 electrical demand. In particular, for the mechanical power, it is possible to note that it is equal to zero during the port stay and
202 when the ship is drifting offshore. This behavior is consistent with the fact that the movement of the propellers, generated by
203 the mechanical power, is stopped when it is not necessary to the movement of the ship.

204 For what regards the thermal power demand, the maximum request occurs, as expected, during the winter period while it is
205 minimum during the summer, when only the hot water needs are accounted. The maximum request of thermal power is equal
206 to slightly more than 7 MW: the shape of the load curve shows two peaks respectively during the first hours of the day and
207 between 7:00 PM and 9:00 PM.

208 Furthermore, it can be observed that electrical and thermal power are never equal to zero. This evidence can be explained
209 considering that the continued operation of safety systems (smoke detectors, gas detectors, fixed fire-fighting equipment,
210 alarms, emergency lights, etc.) and minimum comfort on-board (lighting, entertainment, space heating, hot water, etc.) are
211 ensured. Moreover, being a vessel used for passengers' transport, it must always be guaranteed electrical power (in addition to
212 lighting, also for equipment for the preservation and preparation of food, refrigerators, etc.) and thermal power (for example
213 for the heating of the cabins) also during the port stay phase. On the other hand, during the summer a cooling power is required
214 and, as can be noted from the figure, its trend is almost constant with an average value around 1'000 kW.

215 2.2 Energy Systems

216 The ship is currently equipped with eight marine diesel engines (PM) according to the scheme presented in **Figure 5**. Four
217 *main engines* (4× Wärtsilä 6L46 – from PM#01 to PM#04 in **Figure 5**) for mechanical power production and four *auxiliaries'*
218 *engines* (4× Wärtsilä 6L32 – from PM#05 to PM#08 in **Figure 5**) for electrical power production are installed. The PM design
219 performance are listed in **Table 1**.

220 All the PM on board are medium speed [47-48], being characterized by 500 RPM and 750 RPM respectively for main and
221 auxiliary engines.
222

223 As it can be observed from **Figure 5**, the *main engines* are divided in two groups (gearboxes), each one providing energy to
 224 only one propeller. It follows that the mechanical demand is divided into two equal parts which means that at least two main
 225 engines are always operated if mechanical power is requested.

226 The ship thermal demand can be satisfied by recovering waste heat from all the eight engines and by the use of two auxiliary
 227 boilers. The two auxiliary boilers are characterized by a maximum thermal power output equal to 4'500 kW (each) and by a
 228 thermal efficiency in design condition equal to 80 %. Furthermore, a compression chiller system is included for cooling power
 229 production. This chiller shows a maximum cooling power output equal to 2'000 kW with an EER assumed equal to 3.5, in
 230 design condition.
 231

232 3. CALCULATION MODEL

233 In order to minimize the ship fuel consumption, an in-house-developed software has been applied [49]. In details, this software
 234 – developed by University of Bologna and named EGO (**E**nergy **G**rids **O**ptimizer) – is able to define the load distribution of a
 235 number of energy systems operating into a grid, with the aim of minimizing the total cost of energy production.

236 In particular, the realized software can simulate an energy grid consisting in (i) an arbitrary number of prime movers (PM)
 237 even in CHP (Combined Heat and Power) application, (ii) generators from renewable source (solar thermal panels – RGt –
 238 wind turbines and photovoltaic panels – RGe), (iii) energy storage devices (ES) for both electrical and thermal energy, (iv)
 239 thermal generators (auxiliary boilers – AB – and heat pumps – HP) and (v) cooling machines (compressor – CC – and
 240 absorption chillers – AC). The aforementioned generators are used to cover the electrical, thermal and cooling energy load
 241 requested by a utility (or a group of utilities); the simulated grid can also be connected (if present) with the electric grid and
 242 with the gas distribution network. The adopted software and its regulation strategies and mathematical models have been
 243 validated in [49]. It should be highlighted that the developed software has been adapted for this study: this scenario, indeed,
 244 can be seen as a particular application of energy grid operating without connection to the electric distribution network.

245 The calculation core of the realized in-house-developed software consists of a *genetic algorithm* based on the minimization of
 246 an objective function which expresses the total cost of energy production.

247 The input section requires:

- 248 • electrical, thermal and cooling power required by the utilities; further is also possible to define the gas demand (for direct
 249 use) for the utilities;
- 250 • the number, typology, and main characteristics of:
 - 251 ○ prime movers (electrical and thermal design power output, efficiency, off-design behaviour, etc.);
 - 252 ○ renewable source generators (peak power, performance, etc.);
 - 253 ○ heating and cooling systems (size, performance, off-design behaviour, etc.);
 - 254 ○ electric and thermal energy storage devices (maximum storable energy);
- 255 • the tariff scenario (purchased and sold electric energy value, cost of the fuel, etc.);
- 256 • a series of parameters characteristic of the genetic algorithm (as better explained in the following of this paragraph).

257 The optimal load of each considered energy systems in order to minimize the total cost of the energy supplied to the users and
 258 the costs of energy production represents the main output of the software.
 259

260 3.1 Mathematical Model

261 With the aim to reach the goals of energy efficiency increase and fuel consumption reduction, the configurations analyzed in
 262 this study are based on the specific mathematical model presented in this section. The developed genetic algorithm, indeed, is
 263 based on the minimization of the following fitness function (*FF*):

$$264 FF = C_\lambda + C_M + C_E + C_F \quad E6.1$$

265 where:

- 266 • C_λ is the total cost of fuel and it can be calculated as:

$$267 C_\lambda = \left[\sum_{i=1}^{n_{PM}} f_{\lambda,i}^{PM}(L_{PM,i}) + \sum_{i=1}^{n_{AB}} f_{\lambda,i}^{AB}(L_{AB,i}) \right] \cdot \lambda_{fuel} \quad E6.2$$

268 where the functions $f_{\lambda,i}^{PM}$, $f_{\lambda,i}^{AB}$ express the power introduced with fuel in the i^{th} prime mover or auxiliary boiler as
 269 function of the systems loads ($L_{PM,i}$ and $L_{AB,i}$). Furthermore, λ_{fuel} is the cost of the fuel (expressed as €/kW)
 270 introduced in prime movers and/or auxiliary boilers.
 271

- 272 • C_M is the total maintenance cost of the energy systems. This parameter is estimated as function of the produced power –
 273 electrical (EL), thermal (TH) or cooling (FR) – of each system and is calculated by using maintenance cost specific values
 274 (μ_i expressed in €/kW):

$$275 C_M = \sum_{i=1}^{n_{PM}+n_{RGe}} P_{EL,i} \cdot \mu_{EL,i} + \sum_{i=1}^{n_{RGt}+n_{AB}+n_{BB}+n_{HP}} P_{TH,i} \cdot \mu_{TH,i} + \sum_{i=1}^{n_{CC}+n_{AC}} P_{FR,i} \cdot \mu_{FR,i} \quad E6.3$$

276 where P_i is function of the load of each system $P_i = f(L_i)$.

- 278 • C_E is the total cost of the electricity purchased from the national grid and can be estimated as:

$$C_E = P_{EL,P} \cdot \xi_{EL,P} \quad E6.4$$

being $\xi_{EL,P}$ the specific cost of purchased electricity (€/kW) and $P_{EL,P}$ the total electric power from the distribution network to the users. It can be seen that $P_{EL,P}$, if greater than zero, can be expressed as:

$$P_{EL,P} = \sum_{i=1}^{n_U} P_{EL,i}^U + \sum_{i=1}^{n_{CC}} \frac{P_{FR,i}^{CC}}{f_{EER,i}^{CC}(L_{CC,i})} + \sum_{i=1}^{n_{HP}} \frac{P_{TH,i}^{HP}}{f_{COP,i}^{HP}(L_{HP,i})} - \sum_{i=1}^{n_{RGe}} f_{EL,i}^{RGe}(L_{RGe,i}) - \sum_{i=1}^{n_{PM}} f_{EL,i}^{PM}(L_{PM,i}) - \sum_{i=1}^{n_{ES}} P_{EL,i}^{ES} \quad E6.5$$

The previous expression represents the sum of the electrical power required from the users (U), from the compressor chillers (CC) and from the heat pumps (HP) minus the production of the eventual renewable source generators (RG), of the prime movers and the power recovered from electrical storage devices (ES). Moreover, $f_{COP,i}^{HP}$ and $f_{EER,i}^{CC}$ represent two functions which estimate respectively the energy efficiency ratio (EER) of the cooling machines and the coefficient of performance (COP) of the heat pumps as function of the systems loads ($L_{CC,i}$ and $L_{HP,i}$). Finally, in Eq. E6.5, the function $f_{EL,i}^{PM}$ calculates the produced power of the i^{th} prime mover for a given load ($L_{PM,i}$).

- C_F are the so-called fictitious costs. In details, C_F allows to force the regulation strategy of the whole energy grid according to the rules of the *thermal priority* or of the *electrical priority*. In case of regulation with *thermal priority*, in order to minimize the environmental impact of the prime movers, a fictitious cost has been introduced to take into account the dissipation of thermal power discharged by the prime movers and not used for the utilities. With this regulation strategy, if more electricity is generated compared to utilities' needs and storage availability, surplus can be sold to the network (if connected to the calculated energy grid). Conversely, the regulation strategy with *electrical priority* discourages the sale of electricity to the grid by considering, opposite to the previous case, this option as a cost. This strategy can be adopted in case of a smart grid not connected to the network (such as the case under investigation) or if the national grid is not suitable to accommodate energy.

In case of *thermal priority*, it results:

$$C_F = \sum_{i=1}^{n_{PM}} \frac{Q_{disp,i}}{\eta_{AB,av}} \cdot \lambda_{fuel} \cdot p_T - P_{EL,S} \cdot \xi_{EL,S} \quad E6.6$$

In the previous relationship, it can be observed that the thermal energy dispersed to the stack ($Q_{disp,i}$) is accounted as a cost by considering it as a multiple (p_T) of the corresponding fuel cost used in a conventional boiler to produce the same amount of dispersed heat. In this case, the sale of electricity to the network is accounted as a reduction of the costs of electricity production considering a specific value $\xi_{EL,S}$ (€/kW).

Otherwise, if *electrical priority* is adopted, the fictitious costs become:

$$C_F = P_{EL,S} \cdot \xi_{EL,S} \cdot p_E \quad E6.7$$

where, the sale of electricity to the grid ($P_{EL,S}$) is discouraged considering, as already said, this option as a cost. As well as for *thermal priority*, a multiplication factor (p_E) has been assumed, while the dispersion of heat from the prime movers to the environment is not considered as a cost.

Beyond that, the software allows a *combined priority* which is defined as a mix of the previous strategies. On the basis of the previous equations, it can be written:

$$C_F = \sum_{i=1}^{n_{PM}} \frac{Q_{disp,i}}{\eta_{AB,av}} \cdot \lambda_{fuel} \cdot p_T + P_{EL,S} \cdot \xi_{EL,S} \cdot p_E \quad E6.8$$

Eq. E6.8 clearly shows that with this regulation strategy, both the dissipation of thermal energy to the stack and the sale of electrical energy to the network are simultaneously discouraged. This is the approach adopted for the case studies.

3.2 Genetic Algorithm

In order to minimize the fitness function (FF) the genetic algorithm creates and/or evolves a population of candidate solutions, in which the loads (L_i) of the systems installed within the grid represent the chromosomes of each individual. The values of L_i allow the estimation of the FF on the basis of the previous equations. The evolution of the population starts from a first generation which is randomly generated. This approach, as known, is usually adopted for the genetic algorithm.

It can be noted that the size (p_S) of the population (*i.e.* the number of individuals) is defined as function of the total number the systems (n_{tot}) included in the smart grid. It results:

$$p_S = P_{FM} \cdot (L_{UP} - L_{LO}) \cdot n_{tot} \quad E6.9$$

where L_{UP} and L_{LO} are the upper and lower limits of the variation range of the terms L_i , while P_{FM} is a multiplicative parameter (an integer number greater than 1). P_{FM} represents a tuning parameter which influences the convergence velocity of the algorithm. Low values of P_{FM} mean few individuals for each generation, thus the convergence of the algorithm can require a large number of iterations. On the other hand, high number of individuals reduces the number of required iterations but increases the time required for each iteration.

Once the first generation is created, for each of its individuals the FF is estimated and then a FF rank is created. Solutions with lower values of energy production cost are represented by individuals with lower values of FF and then are recognized as high rank solutions; on the contrary, solutions with higher values of FF become low rank solutions. A defined percentage of lower rank solutions (usually between 50% and 75% of the total population) is automatically eliminated from the generation. The remaining individuals are instead involved into the creation of the next generation. The generation of new individuals follows the crossover method (also known as recombination method) without mutation. This means that two new

334 individuals are generated by two parent individuals. To guarantee that individuals with higher rank have higher probability
335 (under the statistical point of view) of generating a new individual, the selection of the parent individuals is realized with a
336 *roulette method*. The highest rank solution $FFR\#1(i)$ of each generation (with the exception of the first one) is compared
337 with the corresponding of the previous generation, $FFR\#1(i - 1)$. When the difference between these two quantities is lower
338 than a given tolerance value TOL , the procedure ends:

340 $|FFR\#1(i) - FFR\#1(i - 1)| < TOL$ E6.10
341

342 4. HYPOTHESIS AND ASSUMPTIONS

343 In this section, the main hypothesis and assumptions of the study will be presented and discussed. In particular, different on-
344 board energy systems configurations are proposed (section 4.1) and the applied model for the off-design operation of the main
345 engines, the auxiliary engines, the auxiliary boilers, etc. (section 4.2) are discussed.

346 4.1 Energy Systems Configurations and Operational Strategies

347 In order to determinate the optimal configuration and operational strategy for the energy systems of the considered ship, six
348 different configurations have been proposed: the first three strategies are characterized by a standard configuration, that is the
349 current engines regulation, typical for this type of ships.

350 The remaining three strategies, instead, are characterized by a hybrid configuration of the engines, which is broadly used today
351 on the military ships.

352 In details:

353
354 **BC** **Base Case** – the first strategy considers the energy system scheme presented in **Figure 5**, corresponding to
355 the current layout of the vessel. In this case, both the mechanical and electrical powers are satisfied by
356 equally sharing the production among the corresponding engines; this management strategy – not currently
357 adopted in this ship – is based on the *equal incremental cost criterion* which is used in power generation
358 sector [49];

360 **OL** **Optimized Load** – in this second strategy the energy system scheme is still the one shown in **Figure 5**.
361 However, differently from the previous case, the load of each engine is determined by the developed
362 software in order to minimize the fuel consumption and the wasted thermal energy;

364 **OL-S** **Optimized Load with Storage** – in this case, the energy system scheme is the one presented in **Figure 6**,
365 which comes from the one in **Figure 5** with the addition of a thermal storage device; also in this case the
366 load of each engine is determined by the developed software;

368 **HY** **Hybrid** – the fourth strategy is characterized by a different configuration of the engines compared to the
369 previous ones. In this case, in fact, has been considered an hybrid system – as is shown in **Figure 7** – in
370 which all the engines produce electrical power and the propulsion is realized by means of two electrical
371 engines instead of the two gearboxes;

373 **HY-S** **Hybrid with Storage** – the engines configuration is the same of the previous case with the inclusion of a
374 thermal storage tank (see **Figure 8**);

376 **HY-S-AC** **Hybrid with Storage and Absorption Chiller** – in this last strategy, the engines configuration derives
377 from the previous one (HY and HY-S) with a further introduction of an absorption chiller unit, as presented
378 in **Figure 9**.

380 Each of these configurations has been implemented in the EGO software considering the energy demand curves presented in
381 **Figure 4**. The calculation has been developed considering – as already explained – three reference days (winter, summer and
382 spring/fall typical days). The main results of the simulations will be presented for a whole year (365 days) of ship operation.
383 Furthermore, relating to the configurations OL-S, HY-S and HY-S-AC, the thermal storage volume was part of the
384 optimization: the storage volume has been estimated in order to minimize both the auxiliary boilers fuel consumption and the
385 thermal energy from the internal combustion engines wasted through the chimney.

386 4.2 Energy Systems Off-design Operation and Other Assumptions

387 The off-design behavior of the main and of the auxiliary engines was considered according to the curves respectively presented
388 in **Figure 10** and in **Figure 11**. It can be observed that the main engines show the maximum value of mechanical efficiency
389 (44.7 %) for a load equal to the 80 %, while – again with reference to 80 % load – the thermal efficiency reaches its minimum

value (45.3 %). Differently, the auxiliary engines are characterized by a maximum value of electrical efficiency (42.8 %) and a minimum value of thermal efficiency (47.2 %) with reference to full load operation. Further details about the calculation methodology used to derive the curves in **Figure 10** and in **Figure 11** can be found in the Authors' previous paper [37].

As regards the auxiliary boilers, the trend of the thermal efficiency as function of the load is presented in **Figure 12**. This curve, which shows the maximum value (80 %) for a boiler load equal to 30 %, was estimated according to the evidence that generally – for marine applications – boilers are characterized by high performance, even at very low loads [50]. Furthermore, the EER trend as function of compression chiller load is presented in **Figure 13**. The plotted trend is typical of this kind of machines and was estimated according to the literature on this matter [51]. Finally, for what regards the EER of the absorption chiller (see HY-S-AC strategy in **Figure 9**), a constant value equal to 0.67 was considered [51].

A cylindrical insulated tank has been considered as thermal storage device, assuming a global heat exchange coefficient equal to 0.5 W/m²K [52]. As previously mentioned, the choice of the optimal volume of the tank is a result of the developed analysis. Furthermore, for the auxiliary components, such as gearbox, frequency converter, etc. (for simplicity not included in the schemes in **Figure 5** and from **Figure 6** to **Figure 9**, with the exception of electrical engines and of gearboxes between main engines and propellers), a constant value of the efficiency was taken into account. The assumed values are presented in **Table 2** [53–55].

Finally, a constant value of efficiency (equal to 0.97) was assumed for the thermal and cooling energies distribution systems from the production devices to the final users.

5. RESULTS

In this section the results of the yearly simulations for the operational strategies and configurations described in section 4.1 will be presented.

In details, section 5.1 presents the energetic analysis which mainly takes into account the vessel's consumption with a comparison between the different developed strategies; section 5.2 presents a simplified economic analysis with a Net Present Value (NPV) evaluation and introduces a briefly environmental analysis on main pollutant emissions.

5.1 Energetic Analysis

The yearly fuel consumption of the auxiliary boilers and the annual wasted thermal energy trends are presented respectively in **Figure 14** and in **Figure 15**, expressed as function of the thermal storage volume. In these figures, the green line represents the standard configuration, analyzed through the three first strategies (BC, OL and OL-S) while the blue line represents the hybrid configuration (HY, HY-S and HY-S-AC).

From **Figure 14** it can be observed that, compared to the base case strategy (BC), the OL configuration involves a greater auxiliary boilers fuel consumption, as it will be better explained in the following.

By the application of a thermal energy storage to the OL configuration (OL-S strategy) it can be observed that the auxiliary boilers fuel consumption (green line) decreases with the increase in the storage volume. It has to be also observed that for a storage volume equal to 11.5 m³, the consumption increase in OL strategy with respect to the BC strategy can be reduced to zero (see **Figure 14**, red dotted line). With a further increase in the storage volume, it can be noted that the auxiliary boilers fuel consumption reaches the complete boilers shut-down for a storage volume equal to 61 m³ (for this reason, it can be considered as the optimal volume for the standard configuration).

For what regards the hybrid configurations (blue line), from **Figure 14** it can be observed that the fuel consumption of the boilers is greater than the OL strategy (and the Base Case). This occurs without considering the thermal storage. In fact, with the introduction of a storage tank, the boilers fuel consumption decreases and, even in this case, for a value of 22.7 m³ (see red dotted line), it equals the fuel consumption of the BC strategy. Moreover, it can be observed that also for the hybrid strategy, the storage application involves an auxiliary boiler shut-down. In this case this occurs for a tank volume of 69 m³.

Relating to the thermal dissipations, instead, the reverse situation occurs, (see **Figure 15**). In fact, by applying the OL strategy (optimized standard configuration) the heat losses decrease. Moreover, considering the thermal storage, this decrease is greater until a storage volume of 61 m³ beyond which this reduction will be imperceptible.

The same consideration can be done for the hybrid configurations. This strategy, indeed, involve a greater benefit in terms of heat dissipations compared to both the base case and the standard configuration. The storage volume identified as optimal is 69 m³ (HY-S and HY-S-AC strategies).

On the basis of all these considerations, the aforementioned volumes can be fixed as the minimum and the optimal ones. In particular, for the standard configuration they are respectively 11.5 m³ and 61 m³, while for the hybrid configuration they correspond to 22.7 m³ and 69 m³. On the other hand, the optimal thermal storage volumes (that avoid the boilers fuel consumption) evidently correspond to the maximum volumes which allow to recover all the heat discharged from the engines. In other words, the previous assumption means that the maximum values of thermal storage volumes do not necessarily reduce the dispersed thermal energy to zero (see **Figure 15**). In addition, it should be obviously verified the possibility to install these devices on board, according to the available space.

Furthermore, from **Figure 14** it has to be observed that the hybrid configuration is always characterized by a higher auxiliary boilers fuel consumption and a higher optimal storage volume compared to the standard configuration and the base case.

447 However, this is true if only the auxiliary boilers fuel consumption is considered, but – for a better evaluation of the strategies
448 effectiveness – the total fuel consumption (shown in **Figure 16**) should be considered. In **Figure 16** contributions of auxiliary
449 boilers and prime movers to the yearly fuel consumption are presented separately.
450 At the same time, the annual dispersed thermal energy has been reported in **Figure 17**.
451 It must be pointed out that the results presented in these figures are in reference to the optimal volumes of thermal energy
452 storage devices aforementioned, where implemented (OL-S, HY-S and HY-S-AC strategies).
453 From **Figure 16** it can be noted that the maximum fuel consumption is achieved in the base case, with a total amount slightly
454 higher than 104'000 MWh; in this case the total thermal dispersed energy is equal to more than 26'000 MWh (see **Figure 17**).
455 These values decrease with the adoption of an optimal management strategy, as results from the developed calculation code
456 application (OL). The reductions in fuel consumption and dispersed thermal energy, indeed, are respectively close to 8 % and
457 less than 29 %. On this regard, it must be noted that the fuel consumption reduction is due to the fact that, moving from BC to
458 OL strategy, the consumption increase for auxiliary boilers (as aforementioned for **Figure 14**) for an amount around 47 %, is
459 counterbalanced by the consumption decrease for engines (equals about 10 %). This evidence can be explained considering the
460 optimal operation of the engines (which results in a different load allocation with respect to the BC) that increases the
461 conversion efficiency and consequently – being equal for each configuration the produced energy (mechanical, electrical,
462 thermal and cooling) – reduces the available thermal energy from the engines. The adoption of thermal energy storage (OL-S)
463 further reduces the fuel consumption by completely shutting down the auxiliary boilers (as said for **Figure 14**), while the
464 operation of both main and auxiliary engines remains the same of case OL-S.
465 As expected, the optimal volume of thermal storage allows to reduce the dissipated thermal energy up to a value greater than
466 14'000 MWh, which corresponds to about the 57 % reduction with respect to the BC strategy.
467 For what concern the hybrid configurations, instead, the HY strategy allows a reduction of fuel with respect to the base case.
468 Anyway, the total amount of both fuel consumption and dissipated thermal energy is lightly higher than for OL-S
469 configuration. The adoption of a hybrid configuration, indeed, allows a greater flexibility relating to the engines load
470 allocation: it follows that the engines fuel consumption from OL-S to HY reduces from more than 90'000 MWh to 84'400
471 MWh, even if an increase in dispersed thermal energy occurs (about the 4 % greater than OL-S).
472 It should be considered that this slight increase in thermal losses is observed without the use of storage, which means that the
473 engines load allocation of HY appears to be more efficient than OL-S. The absence of thermal storage entails the adoption of
474 auxiliary boilers: in this case about 7'100 MWh of fuel consumption are accounted, representing the highest value among all
475 the analyzed configurations. This evidence confirms the fact that the optimization of load allocation involves a reduction in the
476 engines fuel consumption and a contemporary increase in the auxiliary boilers employment. Thus, considering HY-S, the
477 adoption of the thermal storage allows eliminating all fuel consumption of auxiliary boilers and reducing the dispersed thermal
478 energy to about 10'000 MWh. As already observed for OL and OL-S, also moving from HY to HY-S the thermal storage
479 allows the complete boilers shut-down but does not affect the engines load allocation. Finally, the introduction of absorption
480 chiller, enables the further reduction of the dissipated thermal energy (which decreases of about 72 % and 27 % compared to
481 BC and HY-S respectively). As regards the fuel consumption, HY-S-AC shows a slightly reduction with respect to HY-S,
482 mainly due to the lower electrical demand of the compression chiller.
483 In **Figure 18**, the yearly operational equivalent hours (defined as the ratio between the annual produced energy and the design
484 power) are presented for each system (absorption chiller, compression chiller, auxiliary boilers, main engines – from PM#01 to
485 PM#04 – and auxiliary engines – from PM#05 to PM#08) and for each strategy. It should be highlighted that the reduction of
486 the operational equivalent hours, for a given system, means a reduction of its maintenance costs. Furthermore, from **Figure 18**
487 it can be noted that – moving from BC to OL and OL-S – no variations occur in the operational equivalent hours of the main
488 engines, the auxiliary engines and the compression chiller. The only difference, in these three cases, stands in the equivalent
489 hours of the auxiliary boilers. Likewise, HY and HY-S are characterized by the same values of equivalent hours both in case of
490 main and auxiliary engines. Comparing HY and HY-S with the previous three strategies (BC, OL and OL-S), it is observed an
491 increase in the operational equivalent hours of the main engines and a decrease for auxiliary ones. This is due to the application
492 of the software, which favors the engines with a greater conversion efficiency (see **Table 1**). Furthermore, HY strategy shows
493 an increase in auxiliary boilers' operating hours with respect to the base case (BC), while in HY-S – as already explained – this
494 value is equal to zero. Equivalent hours of compression chiller do not show any changes, as expected, referring to strategies
495 from BC to HY-S. Finally, for HY-S-AC, due to the use of absorption chiller, a reduction of electrical load occurs. This fact
496 clearly results in a reduction of the operational equivalent hours for compression chiller, with a consequent decrease in the use
497 of auxiliary engines. Furthermore, a slightly increase in the operational equivalent hours of main engines is observed.

498 **5.2 Economic and Environmental Analysis**

499 In **Figure 19** the yearly operating costs, accounting for fuel consumption and maintenance costs, are presented.
500 The calculation has been made considering the assumption [56–57] listed in **Table 3**.
501 From **Figure 19** it can be noted that the main contribution to the total variable costs is attributed to the fuel costs. The total
502 maintenance cost value varies between 550'000 € and 580'000 €, representing a small percentage (around 7 %) of the total
503 variable costs. Based on this consideration, it can be said that the maintenance costs can be considered quite constant with the
504 considered strategy. Furthermore, with reference to the figure, it can be noted that OL-S involves a performance improvement
505 in terms of yearly variable costs (around 13 % reduction) with a moderate investment for its application. Compared to the

506 current layout of the ship, the engines configuration remains the same, while the main change is represented by the installation
 507 of a tank for the thermal energy storage.
 508 Relating to HY-S and HY-S-AC, instead, a further reduction on the annual variable costs can be reached (around 18 % and
 509 20 % for HY-S and HY-S-AC respectively, with reference to the fuel cost reduction). In this case, however, it has to be
 510 considered not only the storage tank installation, but also a reconfiguration of the engines from the traditional to the hybrid
 511 operation. Furthermore, HY-S-AC strategy needs an absorption chiller unit installation.
 512 With reference to **Figure 19**, it can be determined the annual money saving for each developed strategy compared to the base
 513 case, considering the differential cash flow.

514 A simplified economic analysis has been carried out based on the Net Present Value (NPV), defined as:
 515

$$NPV = -I_0 + \sum_{i=1}^N \frac{CF_i}{(1+r)^i}$$

516 where I_0 represents the total initial investment cost, r is the discount rate, assumed equal to 7 %, N is the time horizon, and
 517 CF_i is the net cash inflow during the period t .

518 Setting $NPV = 0$, the maximum investment cost sustainable to pay back the expenditure in N years can be determined:
 519

$$I_0 = \sum_{i=1}^N \frac{CF_i}{(1+r)^i}$$

520 The maximum investment cost, calculated for each developed strategy and evaluated considering periods of 2 years (red
 521 columns) and 5 years (blue columns), is shown in **Figure 20**.

522 From the figure, it can be noted that for the OL strategy the investment costs are relatively low, ranging from around
 523 1'000'000 € to around 3'000'000 €. Increasing the complexity of the adopted strategy, the sustainable maximum investment
 524 increases up to 7'000'000 € (HY-S-AC).

525 In the following **Table 4**, the emissions factors of the main pollutant – such as Carbon Oxide (CO), Carbon Dioxide (CO₂),
 526 Nitrogen Oxides (NO_x), Sulphur Oxides (SO_x), Particulate Matters (PMs) and Non-Methane Volatile Organic Compounds
 527 (NMVOC) – have been reported according to the Third IMO GHG study [8]. These values – representing the average
 528 emissions related to the specific naval sector – refers to marine diesel oil (MDO) considered as input fuel used for all the
 529 energy systems: main engines, auxiliary engines and boilers. It has to be noted that these values depend on the engines speed;
 530 in this case, as aforementioned, the engines can be classified as medium-speed engines (see Section 2.2).

531 It has to be specified that the following analysis is a simplified evaluation carried out considering the average values of the
 532 emissions factors and neither pollutant control system or strategies nor the corresponding legislation have been taken into
 533 account.

534 Starting from these emissions factors values, the corresponding emissions quantities – for each developed strategy – have been
 535 calculated and reported in **Figure 21**.

536 From **Figure 21a** it can be noted that, for what regards the CO₂ emissions, they vary from a maximum of about 30'000
 537 ton_{CO2}/year to a minimum of about 24'000 ton_{CO2}/year, corresponding to the Base Case and the HY-S-AC strategies,
 538 respectively. Because of these high values, the dioxide carbon can be considered the main pollutant emission.

539 Another significant emission is represented by the Nitrogen Oxides (NO_x), shown in **Figure 21b**. These pollutant emissions,
 540 indeed, range from about 650 kg_{NOx} in HY-S-AC strategy to quite more than 800 ton_{NOx}/year in the base case (BC).

541 Other minor but significant pollutant emissions, such as the PMs, CO, NMVOC and SO_x, have been presented in **Figure 21c**.

542 In this figure it can be observed that moving from BC strategy to the HY-S-AC, the Particulate Matter varies from around 8 to
 543 10 tons/year; the SO_x, instead, ranges from about 20 to 25 tons/year; the CO from 21 to 26 tons/year and, finally, the NMVOC
 544 varies from 23 to 29 tons/year. On the whole, it can be observed that the standard configurations (from BC to OL-S) can reach
 545 a maximum decrease of the pollutant emissions equal to 14 %; with the hybrid configurations, these emissions further decrease
 546 up to 20 % (from BC to HY-S-AC).
 547

548 6. CONCLUDING REMARKS

549 One of the major challenges that world has to face today consists of new strategies development in order to improve energy
 550 efficiency and to reduce pollutant emissions. In particular, the contribution of the maritime transport to greenhouse gases
 551 emission cannot be neglected and more than 40 % of the total shipping costs is attributed to fuel consumption.

552 In this paper five different strategies to improve the energy efficiency of a medium size cruise ship have been developed and
 553 compared to actual cruise operation. In more detail, two general main configurations have been considered: the standard
 554 configuration, which is the current engine system of the vessel without any substantial change except for the storage tank
 555 application – *i.e.* base case (BC), optimized load (OL) and optimized load with storage (OL-S) strategies – and the hybrid
 556 configuration, which considers a different engines equipment and, in some case, the storage tank introduction – *i.e.* hybrid
 557 (HY), hybrid with storage (HY-S) and hybrid with storage and absorption chiller (HY-S.AC) strategies.

558 For each of the developed strategies, energy, economic and environmental analyses have been conducted. For what concerns
559 the energetic evaluation, a parametric analysis on the storage volume has been carried out to minimize the annual amount of
560 both the auxiliary boilers fuel consumption and heat losses. From this analysis, the optimal and the maximum storage volume
561 have been identified. Furthermore, the equivalent hours of operation for each of the considered strategies have been evaluated.
562 The results show that the developed strategies allow to reach both a yearly fuel consumption and dispersed thermal energy
563 decrease compared to current engines operation. These advantages become significant if a thermal storage tank is considered.
564 As regards the standard scenario, the optimal volume has to be considered between 11.5 m³ and 61 m³; for the hybrid scenario,
565 instead, the minimum and maximum values are 22.7 m³ and 69 m³, respectively. On the whole, the total annual operational
566 equivalent hours, to which are associated the maintenance costs, decreases for those strategies that include the thermal energy
567 storage.
568 For what regards the economic analysis, a simplified Net Present Value evaluation, based on the differential cash flow has
569 been made, in order to investigate the maximum investment cost to pay back the expenditure of each strategies in 2 and 5
570 years. The annual variable costs of each strategy and in particular the maintenance and fuel costs have been considered,
571 highlighting the strong influence of the fuel cost on the total outlay.
572 Finally, a simplified environmental analysis has been carried out considering the main pollutant emissions, such as CO, CO₂,
573 NO_x, SO_x, PMs and NMVOC. From the results appear that the maximum reduction of the pollutant emission can be reached
574 applying the HY-S-AC strategy (about 20 %). In terms of CO₂, a yearly reduction of about the 20 % can be achieved (HY-S-
575 AC).
576
577

REFERENCES

- 579 [1] Johnson, H., & Styhre, L. (2015). Increased energy efficiency in short sea shipping through decreased time in
580 port. *Transportation Research Part A: Policy and Practice*, 71, 167-178.
- 581 [2] Rehmatulla, N., & Smith, T. (2015). Barriers to energy efficiency in shipping: A triangulated approach to investigate the
582 principal agent problem. *Energy Policy*, 84, 44-57.
- 583 [3] Wang, K., Yan, X., Yuan, Y., & Li, F. (2016). Real-time optimization of ship energy efficiency based on the prediction
584 technology of working condition. *Transportation Research Part D: Transport and Environment*, 46, 81-93.
- 585 [4] Rahim, M. M., Islam, M. T., & Kuruppu, S. (2016). Regulating global shipping corporations' accountability for reducing
586 greenhouse gas emissions in the seas. *Marine Policy*, 69, 159-170.
- 587 [5] Liljestrand, K. (2016). Improvement actions for reducing transport's impact on climate: A shipper's
588 perspective. *Transportation Research Part D: Transport and Environment*, 48, 393-407.
- 589 [6] Quadrelli, R., & Peterson, S. (2007). The energy-climate challenge: recent trends in CO₂ emissions from fuel
590 combustion. *Energy policy*, 35(11), 5938-5952.
- 591 [7] Jang, S. H., & Choi, J. H. (2016). Comparison of fuel consumption and emission characteristics of various marine heavy
592 fuel additives. *Applied Energy*, 179, 36-44.
- 593 [8] Smith, T.W.P., Jalkanen, J.P., Anderson, B.A., Corbett, J.J., Faber, J., Hanayama, S., et al. Third IMO GHG Study.
594 London, UK; 2014.
- 595 [9] Anderson, K., Bows, A. Executing a Scharnow turn: reconciling shipping emissions with international commitments on
596 climate change. *Carbon Manage* 2012;3:615-28.
- 597 [10] Lindstad, H. E., & Eskeland, G. S. (2016). Environmental regulations in shipping: Policies leaning towards globalization
598 of scrubbers deserve scrutiny. *Transportation Research Part D: Transport and Environment*, 47, 67-76.
- 599 [11] EC. Roadmap to a single european transport area – towards a competitive and resource efficient transport system.
600 Brussels, Belgium; 2011.
- 601 [12] Norstad, I., Fagerholt, K., Laporte, G. Tramp ship routing and scheduling with speed optimization. *Transp Res Part C*
602 *Emerg Technol* 2011;19:853-65.
- 603 [13] Nishida, T., Katori, M., Uzawa, K., Ohuchi, K., Waseda, T. Optimization of integrated weather routing systems for sailing
604 cargo ships. In: *Proceeding 21st int offshore polar eng conf*, Maui, USA, vol. 8; 2011. p. 283-9.
- 605 [14] Shao, W., Zhou, P., Thong, S.K. Development of a novel forward dynamic programming method for weather routing. *J*
606 *Mar Sci Technol* 2006;11:239-51.
- 607 [15] Kim, H., Choi, S.S., Hong, C., Yoo, S., Seo, J., Hwangbo, S., et al. Development and application of trim optimization and
608 parametric techniques using an evaluation system (SoLuTion) based on the RANS for improvement of EEOI. *ASME*;
609 2013. p. 784-91. vol. 2 CFD VIV.
- 610 [16] Moustafa, M.M., Yehia, W., Hussein, A.W. Energy efficient operation of bulk carriers by trim optimization. In: *Altosole*
611 *M, Francescutto A, editors. Proc 18th int conf ships shipp res*, Lecco, Italy; 2015.
- 612 [17] Petersen, J.P., Winther, O., Jacobsen, D.J. A machine-learning approach to predict main energy consumption under
613 realistic operational conditions. *Sh Technol Res* 2012;59:64-72.
- 614 [18] Kindt, S. State-of-the-art MAN B & W two-stroke super-long-stroke engines. *Proc Congr Int Counc Combust Engines*
615 2013.
- 616 [19] Imperato, M. Some experimental experience gained with a medium-speed diesel research engine. *Proc Congr Int Counc*
617 *Combust Engines* 2010.
- 618 [20] Risse, S., Gmbh, K.B., Buchmann, K. New turbochargers for modern large engines with low emissions and high
619 performance. *Proc Congr Int Counc Combust Engines* 2013.
- 620 [21] Aesoy, V., Magne Einang, P., Stenersen, D., Hennie, E., Valberg, I. LNG-fuelled engines and fuel systems for medium-
621 speed engines in maritime applications; 2011. <http://dx.doi.org/10.4271/2011-01-1998>.
- 622 [22] Xie, G. Optimal preliminary propeller design based on multi-objective optimization approach. *Procedia Eng*
623 2011;16:278-83.
- 624 [23] Motley, M.R., Nelson, M., Young, Y.L. Integrated probabilistic design of marine propulsors to minimize lifetime fuel
625 consumption. *Ocean Eng* 2012;45:1-8.
- 626 [24] Hochkirch, K., Heimann, J., Bertram, V. Hull optimization for operational profile - the next game level. *V Int Conf*
627 *Comput Methods Mar Eng* 2013.
- 628 [25] Johnson, H., Johansson, M., & Andersson, K. (2014). Barriers to improving energy efficiency in short sea shipping: an
629 action research case study. *Journal of Cleaner Production*, 66, 317-327.
- 630 [26] Johnson, H., & Andersson, K. (2011). The energy efficiency gap in shipping-barriers to improvement. In *International*
631 *Association of Maritime Economists (IAME) Conference*.
- 632 [27] Baldi, F., Gabrielli, C., Melino, F., Bianchi, M. A Preliminary Study on the Application of Thermal Storage to Merchant
633 Ship
- 634 [28] Lashway, C. R., Elsayed, A. T., & Mohammed, O. A. (2016). Hybrid energy storage management in ship power systems
635 with multiple pulsed loads. *Electric Power Systems Research*, 141, 50-62.
- 636 [29] Bassam, A. M., Phillips, A. B., Turnock, S. R., & Wilson, P. A. (2016). An improved energy management strategy for a
637 hybrid fuel cell/battery passenger vessel. *International Journal of Hydrogen Energy*, 41(47), 22453-22464.
- 638 [30] Salmi, W., Vanttola, J., Elg, M., Kuosa, M., & Lahdelma, R. (2017). Using waste heat of ship as energy source for an
639 absorption refrigeration system. *Applied Thermal Engineering*.

- 640 [31] Mondejar, M. E., Ahlgren, F., Thern, M., & Genrup, M. (2017). Quasi-steady state simulation of an organic Rankine cycle
641 for waste heat recovery in a passenger vessel. *Applied Energy*, 185, 1324-1335.
- 642 [32] Michos, C. N., Lion, S., Vlaskos, I., & Taccani, R. (2017). Analysis of the backpressure effect of an Organic Rankine
643 Cycle (ORC) evaporator on the exhaust line of a turbocharged heavy duty diesel power generator for marine
644 applications. *Energy Conversion and Management*, 132, 347-360.
- 645 [33] Zhao, M., Wei, M., Song, P., Liu, Z., & Tian, G. (2016). Performance evaluation of a diesel engine integrated with ORC system. *Applied Thermal*
646 *Engineering*.
- 647 [34] Freeman, J., Hellgardt, K., & Markides, C. N. (2017). Working fluid selection and electrical performance optimisation of
648 a domestic solar-ORC combined heat and power system for year-round operation in the UK. *Applied Energy*, 186, 291-
649 303.
- 650 [35] Feng, X., Zourntos, T., Butler-Purrrv, K. L., & Mashavekh, S. (2010, July). Dynamic load management for NG IPS ships.
651 In *Power and Energy Society General Meeting, 2010 IEEE* (pp. 1-8). IEEE.
- 652 [36] Kanellos, F. D. (2014). Optimal power management with GHG emissions limitation in all-electric ship power systems
653 comprising energy storage systems. *IEEE Transactions on Power Systems*, 29(1), 330-339.
- 654
- 655 [37] Baldi, F., Ahlgren, F., Melino, F., Gabriellii, C., & Andersson, K. (2016). Optimal load allocation of complex ship power
656 plants. *Energy Conversion and Management*, 124, 344-356.
- 657 [38] Radan, D., Johansen, T. A., Sorensen, A. J., & Adnanes, A. K. (2005). Optimization of load dependent start tables in
658 marine power management systems with blackout prevention. *WSEAS Transactions on circuits and systems*, 4(12), 1861-
659 1866.
- 660 [39] Chen, C., Duan, S., Cai, T., Liu, B., & Hu, G. (2011). Optimal allocation and economic analysis of energy storage system
661 in microgrids. *IEEE Transactions on Power Electronics*, 26(10), 2762-2773.
- 662 [40] Türkoğulları, Y. B., Taskın, Z. C., Aras, N., & Altinel, İ. K. (2016). Optimal berth allocation, time-variant quay crane
663 assignment and scheduling with crane setups in container terminals. *European Journal of Operational Research*, 254(3),
664 985-1001.
- 665 [41] Garfinkel, R. S., & Nemhauser, G. L. (1972). *Integer programming* (Vol. 4, pp. 214-216). New York: Wiley.
- 666
- 667 [42] Dai, R., & Mesbahi, M. (2013). Optimal power generation and load management for off-grid hybrid power systems with
668 renewable sources via mixed-integer programming. *Energy Conversion and Management*, 73, 234-244.
- 669 [43] Skjong, E., Johansen, T. A., Molinas, M., & Sørensen, A. J. (2017). Approaches to Economic Energy Management in
670 Diesel-Electric Marine Vessels. *IEEE Transactions on Transportation Electrification*, 3(1), 22-35.
- 671 [44] Climate Change Knowledge Portal – <http://sdwebx.worldbank.org/climateportal/>
- 672 [45] Wärtsilä 46 – Project guide for marine application
- 673 [46] Wärtsilä Engines – Wärtsilä 32
- 674 [47] Ntziachristos, L., Saukko, E., Lehtoranta, K., Rönkkö, T., Timonen, H., Simonen, P., ... & Keskinen, J. (2016). Particle
675 emissions characterization from a medium-speed marine diesel engine with two fuels at different sampling
676 conditions. *Fuel*, 186, 456-465.
- 677 [48] Andersson, K., Brynolf, S., Lindgren, J. F., & Wilewska-Bien, M. (Eds.). (2016). *Shipping and the Environment:
678 Improving Environmental Performance in Marine Transportation*. Springer
- 679 [49] Ancona, M. A., Bianchi, M., Branchini, L., De Pascale, A., Melino, F., Orlandini, V., Peretto, A., “Generation Side
680 Management in Smart Grid”, Proceedings of ASME-ATI-UIT 2015 Conference on Thermal Energy Systems: Production,
681 Storage, Utilization and the Environment, 17 – 20 May, 2015, Napoli, Italy – ISBN 978-88-98273-17-1
- 682 [50] Cohen, L., Fritz, W.A. Efficiency determination of marine boilers: input-output versus heat-loss method. *J Eng Power*
683 1962:39–43.
- 684 [51] Macchi, E., Campanari, S., Silva, P. (2005). La microgenerazione a gas naturale (p. 304). Polipress ISBN: 8873980163
- 685 [52] Ancona, M. A., Bianchi, M., Diolaiti, E., Giannuzzi, A., Marano, B., Melino, F., Peretto, A. (2016). A novel solar
686 concentrator system for combined heat and power application in residential sector. *Applied Energy*. In Press, Corrected
687 Proof, Available online 25 March 2016, doi:10.1016/j.apenergy.2016.03.026
- 688 [53] Shi, W., Stapersma, D., Grimmeliuss, H.T. Analysis of energy conversion in ship propulsion system in off-design
689 operation conditions. *WIT Trans Economy Environ* 2009;121:461–72.
- 690 [54] Dedes, E., Hudson, D.A., Turnock, S.R. Assessing the potential of hybrid energy technology to reduce exhaust emissions
691 from global shipping. *Energy Policy* 2012;40:204–18.
- 692 [55] Adanes, A.K. Maritime electrical installations and diesel electric propulsion. ABB AS Marine 2003.
- 693 [56] Andreoni, V., Miola, A., & Perujo, A. (2008). Cost effectiveness analysis of the emission abatement in the shipping sector
694 emissions. European Commission Joint Research Centre Institute for Environment and Sustainability, Luxembourg.
- 695 [57] Gunnarsson, G., Skúlason, J. B., Sigurbjarnarson, Á., Enge, S., (2016). Regenerative electric/hybrid drive train for ships –
696 RENSEA II, nordic innovation publication 2016:02
697 (http://www.nordicinnovation.org/Global/Publications/Reports/2016/Rensea%20rapport_final.pdf)

Table 1 – Internal combustion engines design performance [44–45]

Model	Wärtsilä 6L46	Model	Wärtsilä 6L32
Mechanical Power [kW]	5850	Electrical Power [kW]	2760
Thermal Power [kW]	6081	Thermal Power [kW]	3049
Mechanical Efficiency [-]	0.44	Electrical Efficiency [-]	0.43
Thermal Efficiency [-]	0.46	Thermal Efficiency [-]	0.47

Table 2 – Auxiliary components efficiencies [53–55]

Component	η_{des}
Gearbox	0.98
Generator	0.97
Electrical Engine	0.96
Frequency converter	0.98
Shaft	0.98

Table 3 – Specific variable costs [56–57]

Costs	€/kWh
Fuel	0.0843
Main Engine maintenance	0.0150
Auxiliary Engine maintenance	0.0150
Auxiliary Boilers maintenance	0.0060
Compression Chiller maintenance	0.0050
Absorption Chiller maintenance	0.0025

Table 4 – Emissions factor for MDO [8]

Emission substance	E.F. [kg/kg fuel]
CO	0.00277
CO ₂	3.20600
NO _x	0.08725
SO _x	0.00264
PMs	0.00102
NM VOC	0.00308

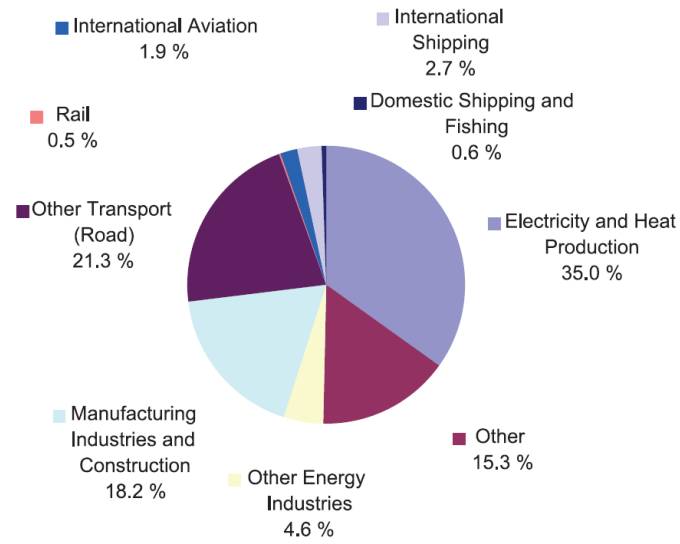

Figure 1: CO₂ emissions from fuel combustion in 2014, for different sectors [6]

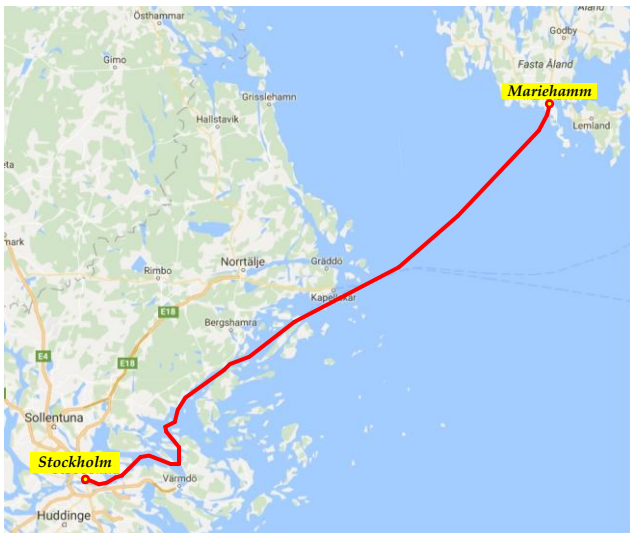

Figure 2 – Schematic of the cruise ship route

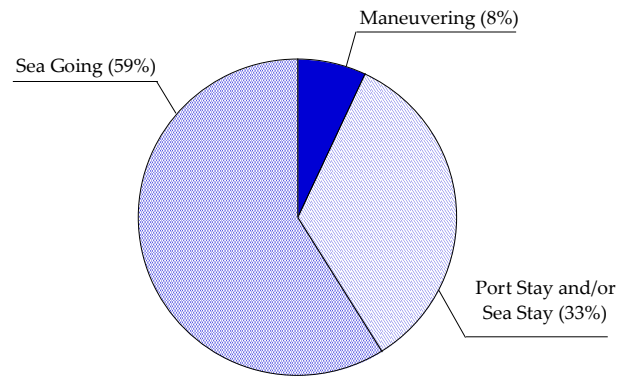

Figure 3 – Operational profile

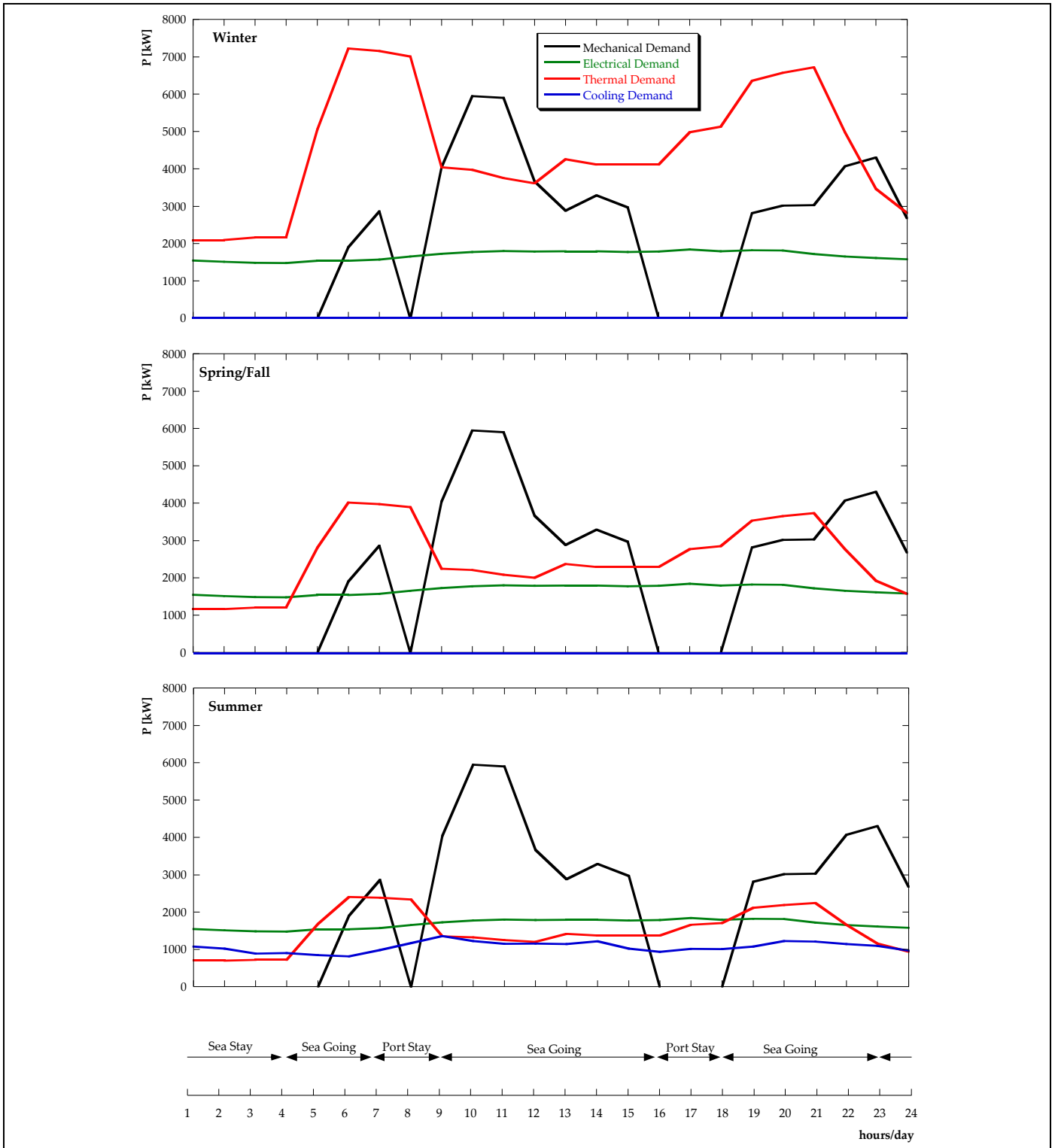

Figure 4 – Hourly load curves for typical days during winter, spring/fall and summer

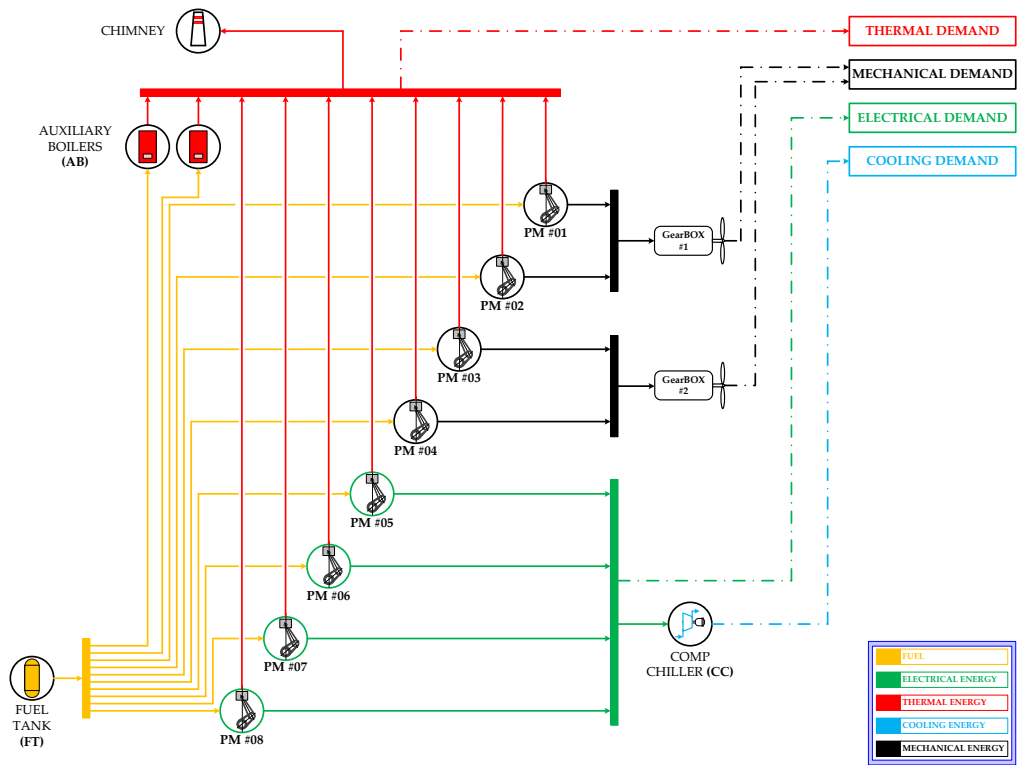

Figure 5 – Base case (BC) layout

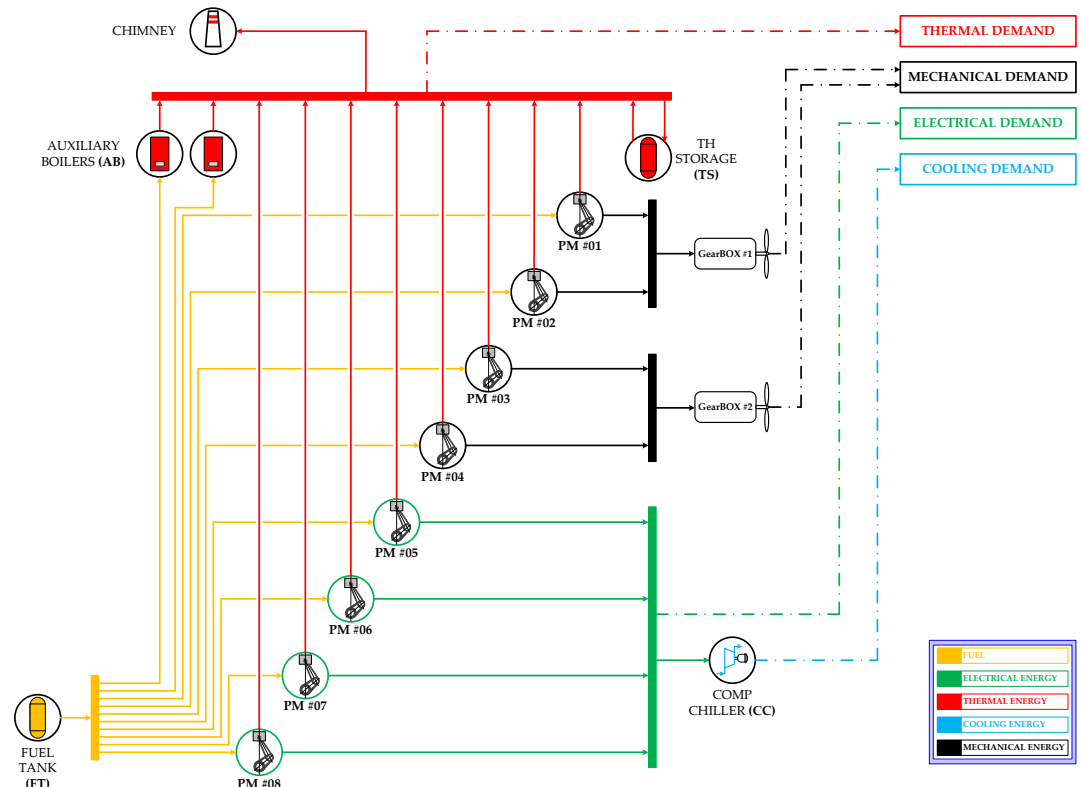

Figure 6 – Optimized load with storage (OL-S) layout

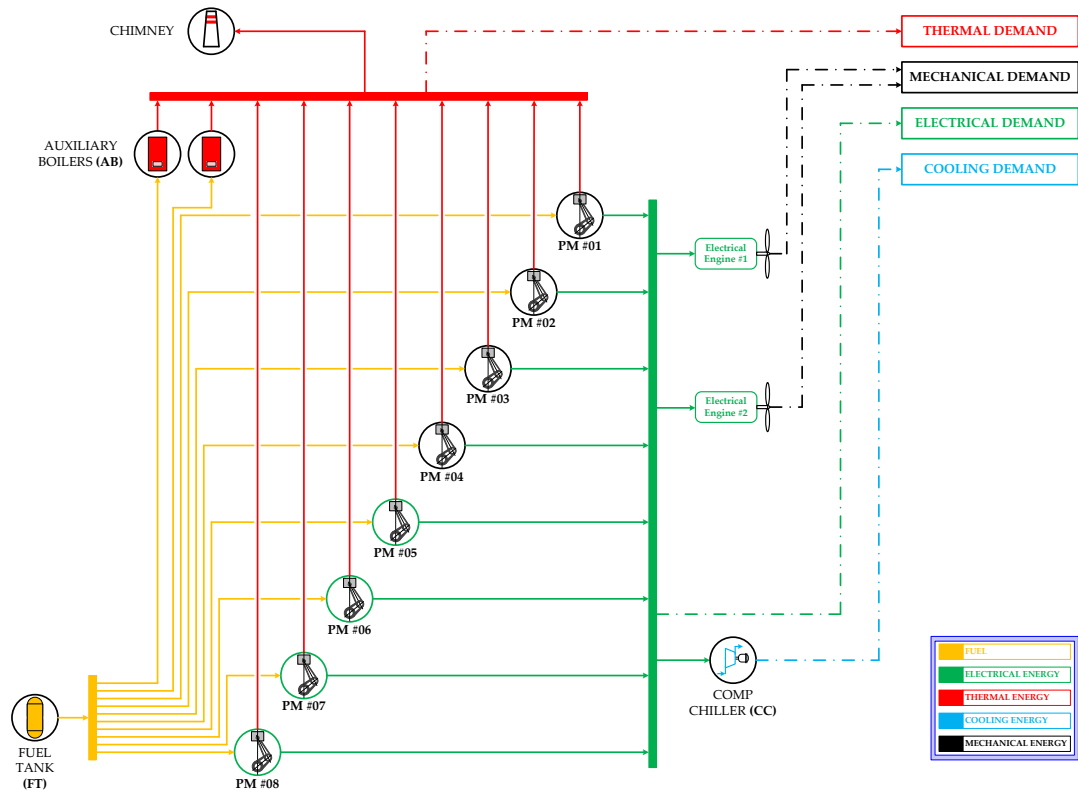

Figure 7 – Hybrid (HY) layout

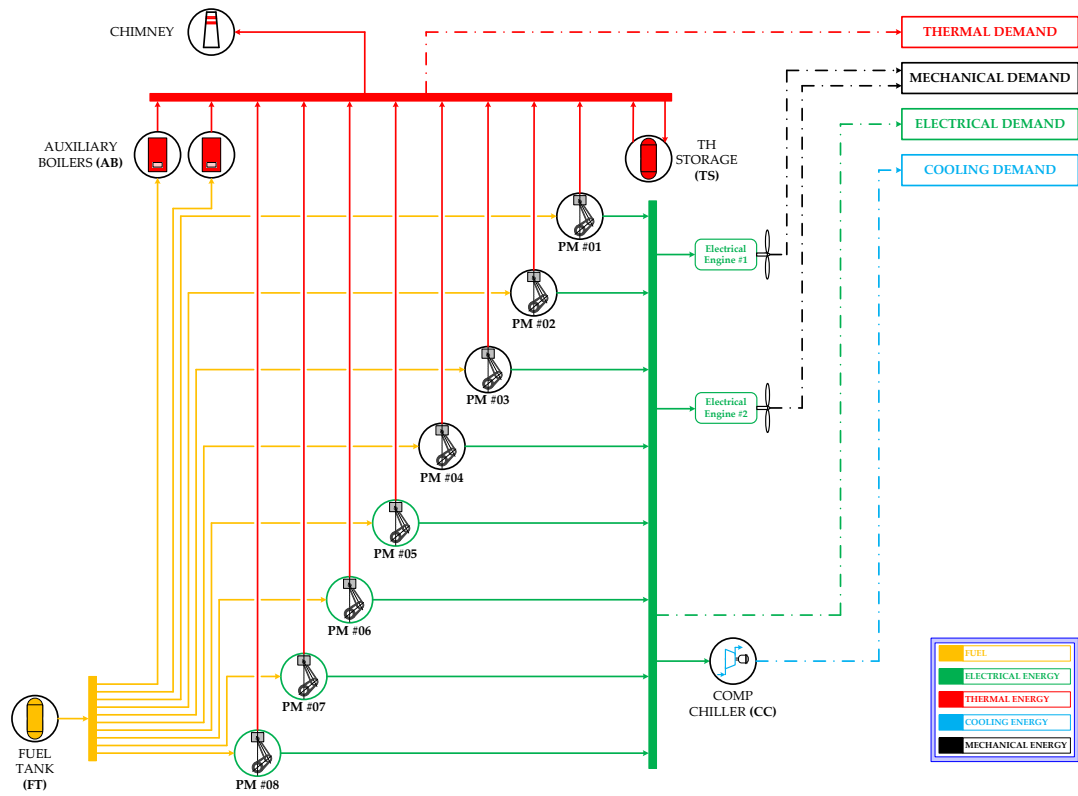

Figure 8 – Hybrid with storage (HY-S) layout

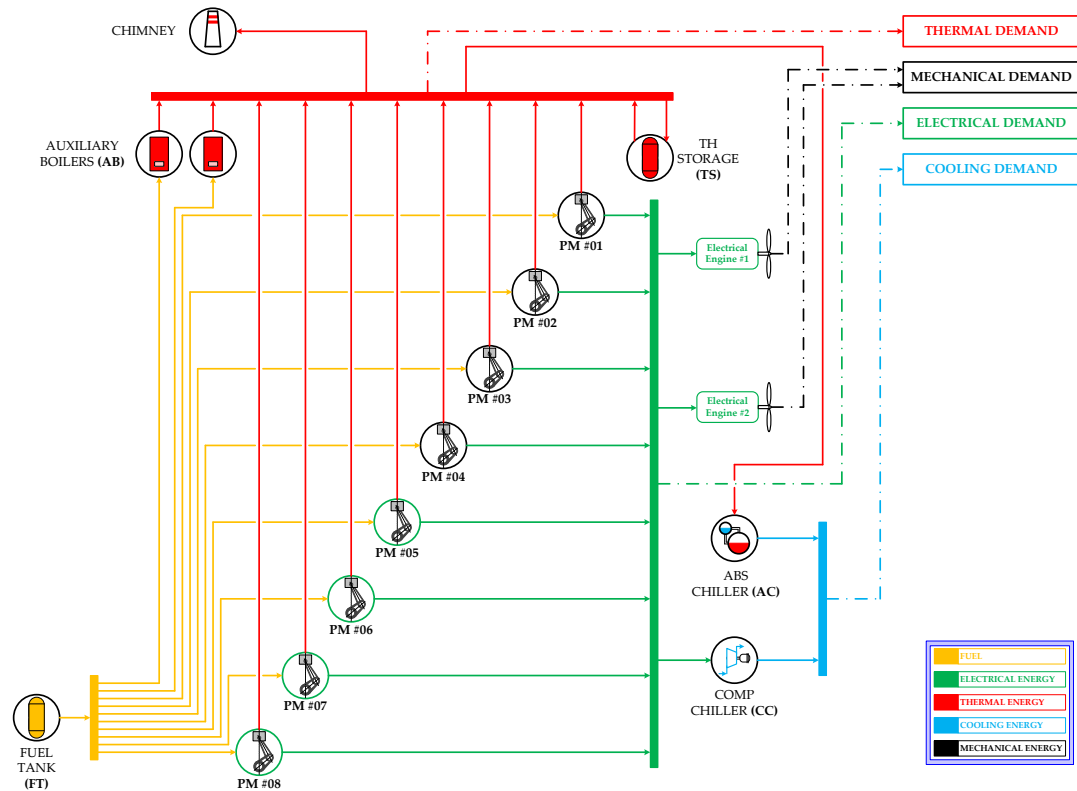

Figure 9 – Hybrid with storage and absorber chiller (HY-S-AC) layout

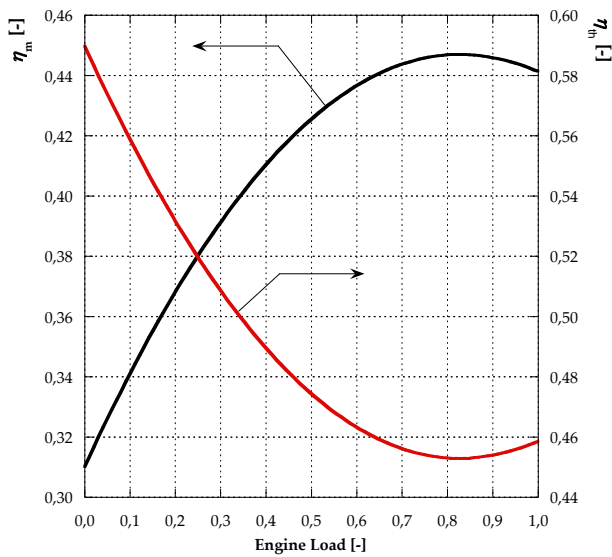

Figure 10 – Mechanical and thermal efficiency as function of load for main engines

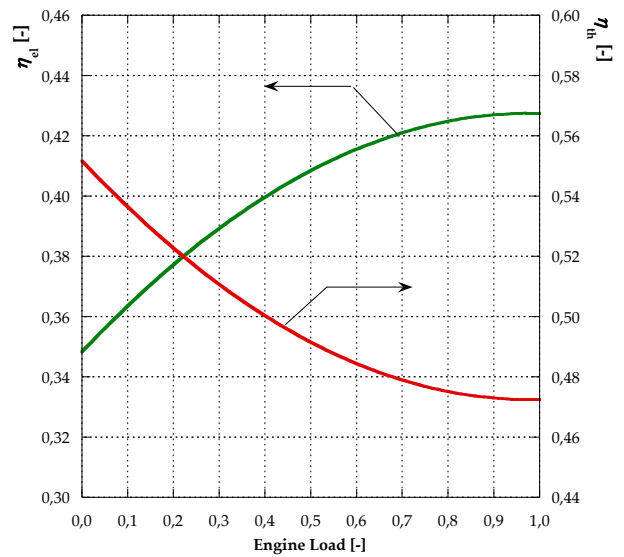

Figure 11 – Electrical and thermal efficiency as function of load for auxiliary engines

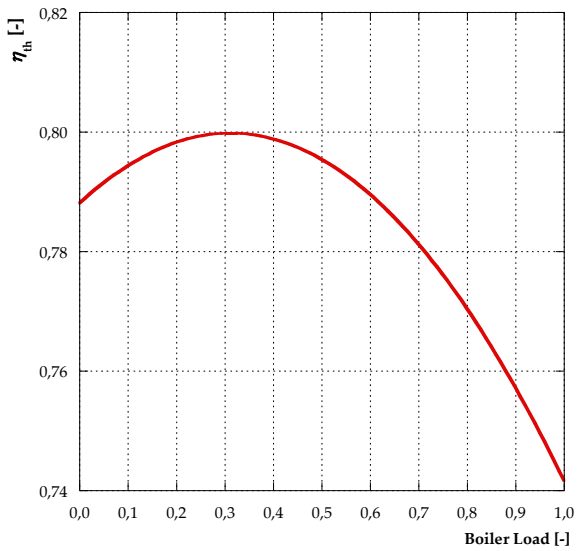

Figure 12 – Thermal efficiency as function of load for auxiliary boilers

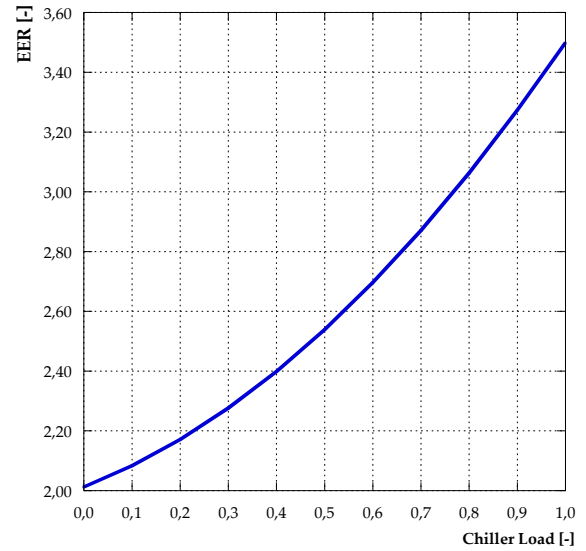

Figure 13 – EER as function of load for compression chiller

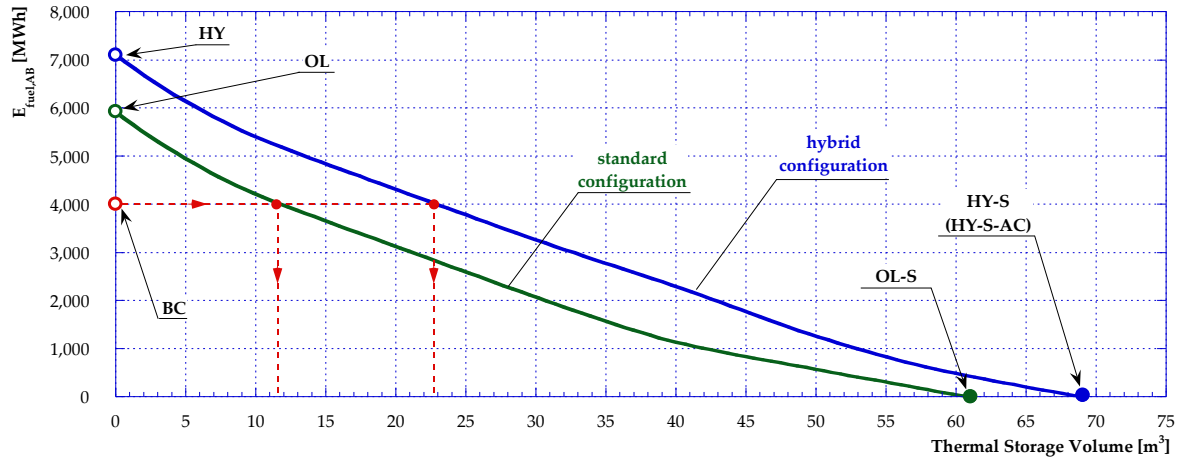

Figure 14 – Annual auxiliary boilers fuel consumption as function of the storage volume

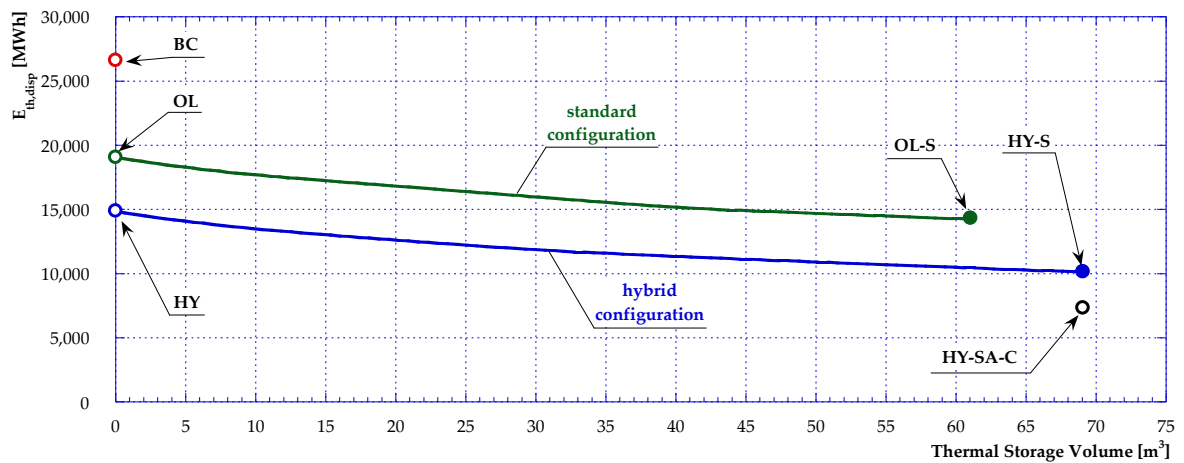

Figure 15 – Annual thermal dissipations as function of the storage volume

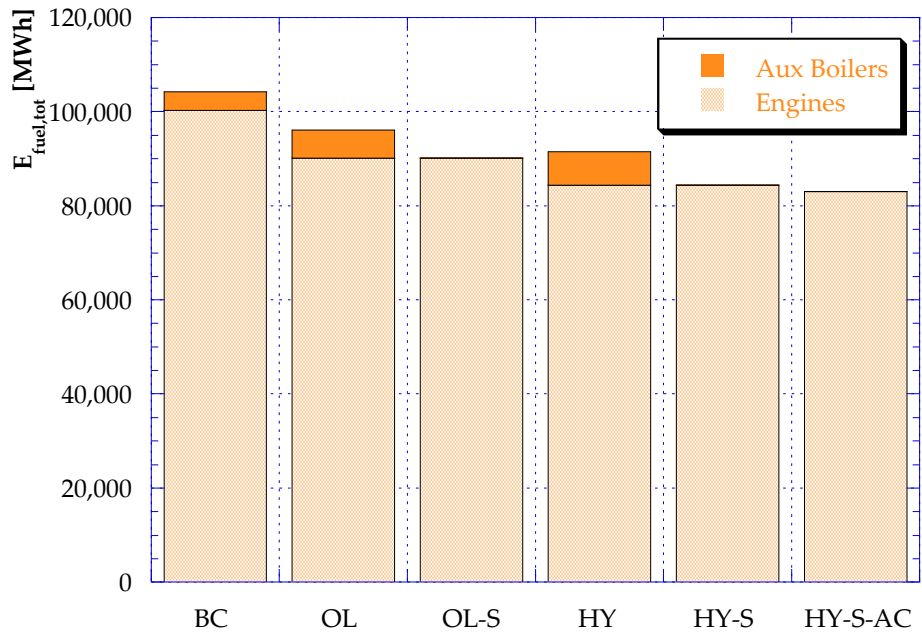

Figure 16 – Annual total fuel consumption

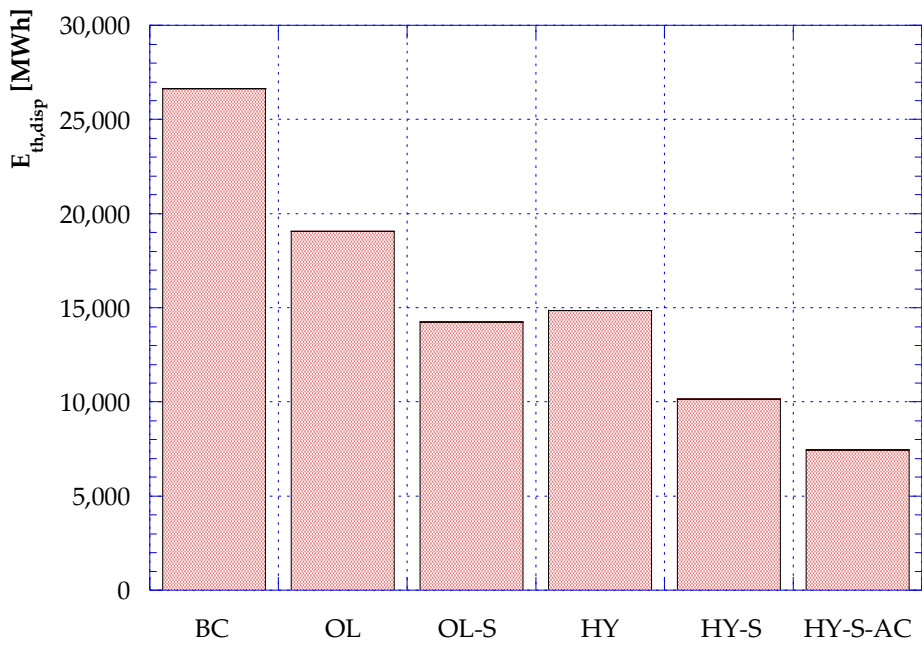

Figure 17 – Annual total dissipations

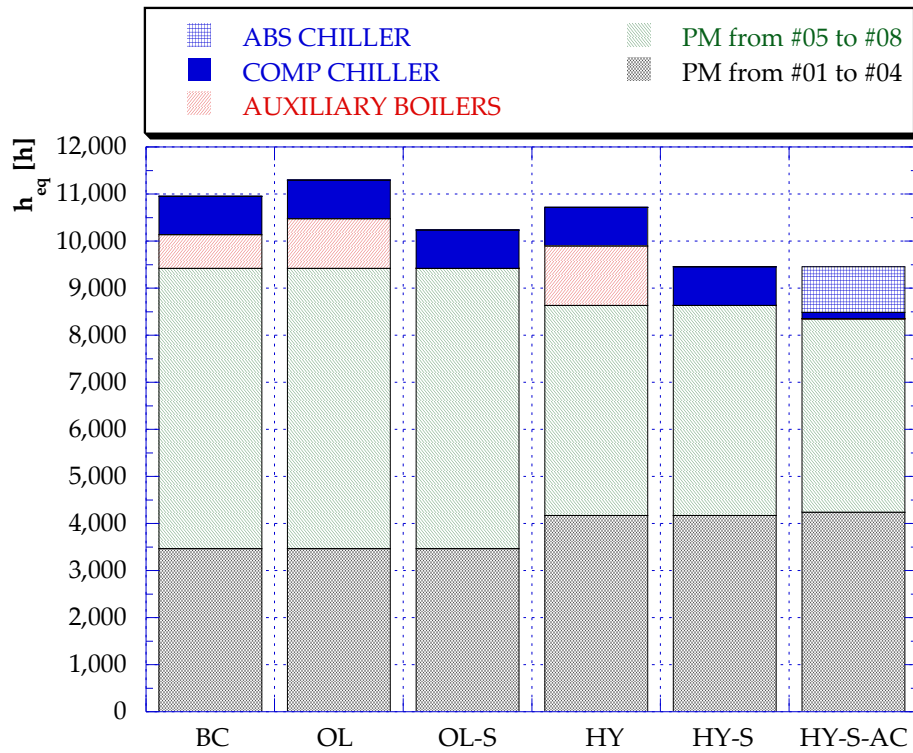

Figure 18 – Annual equivalent hours of operation

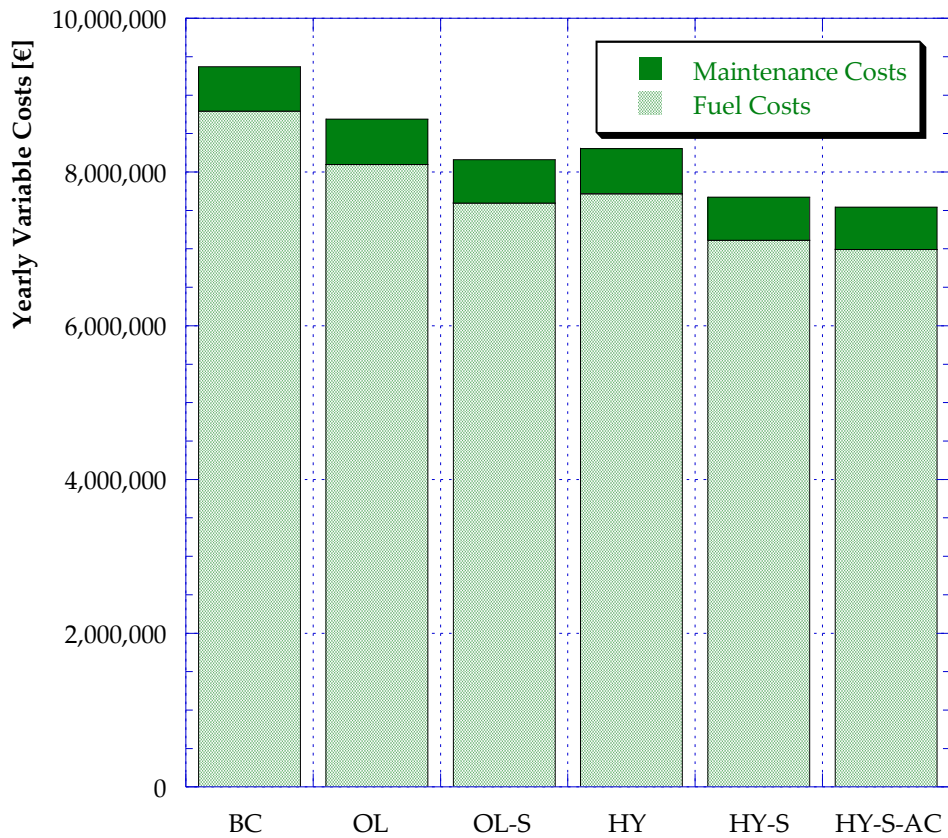

Figure 19 – Annual fuel costs and maintenance costs

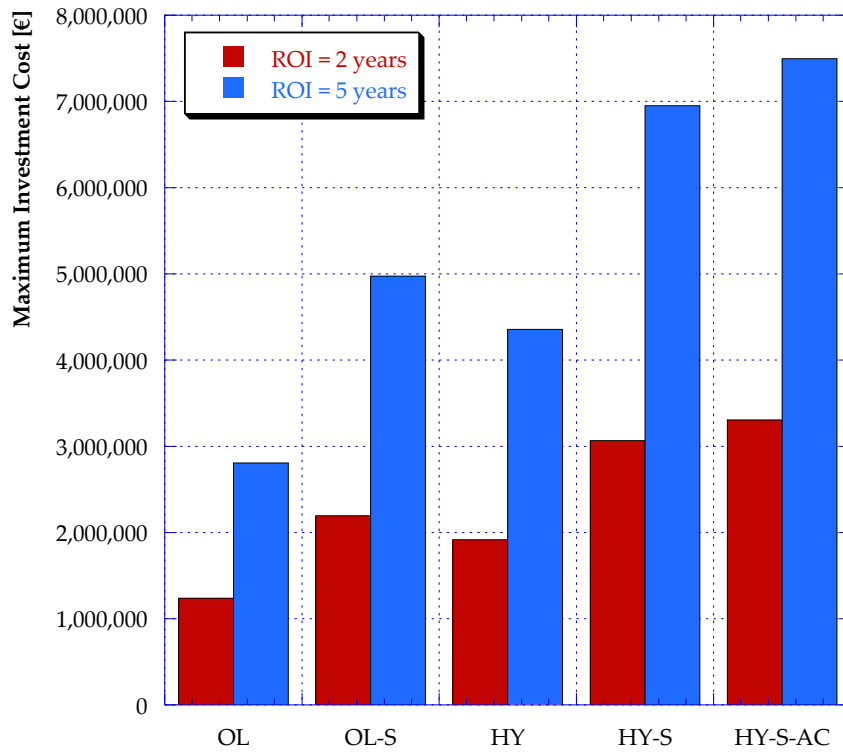
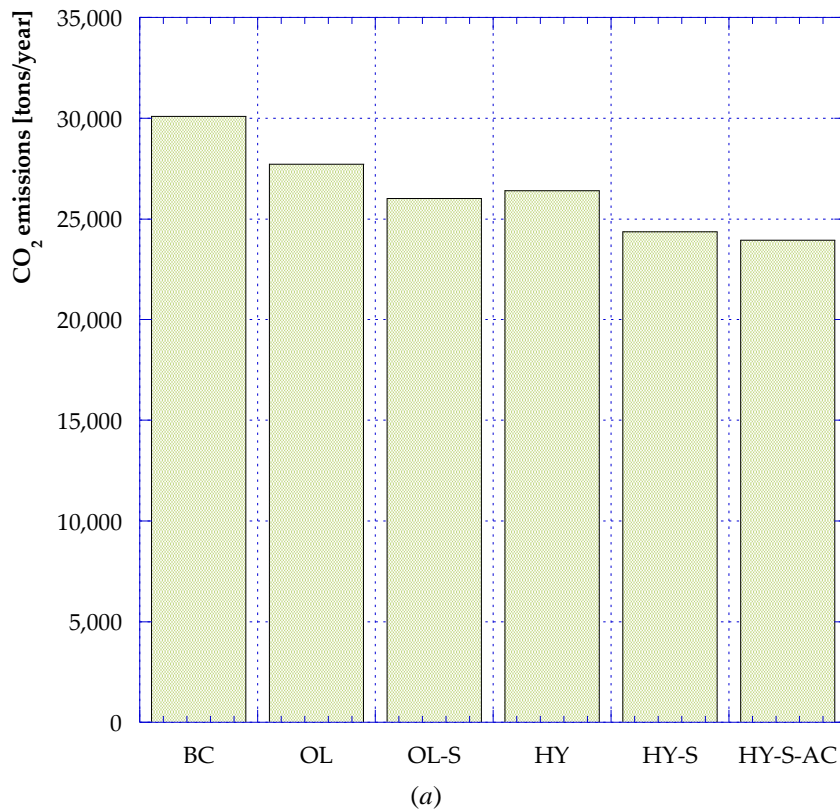

Figure 20 – Maximum investment costs



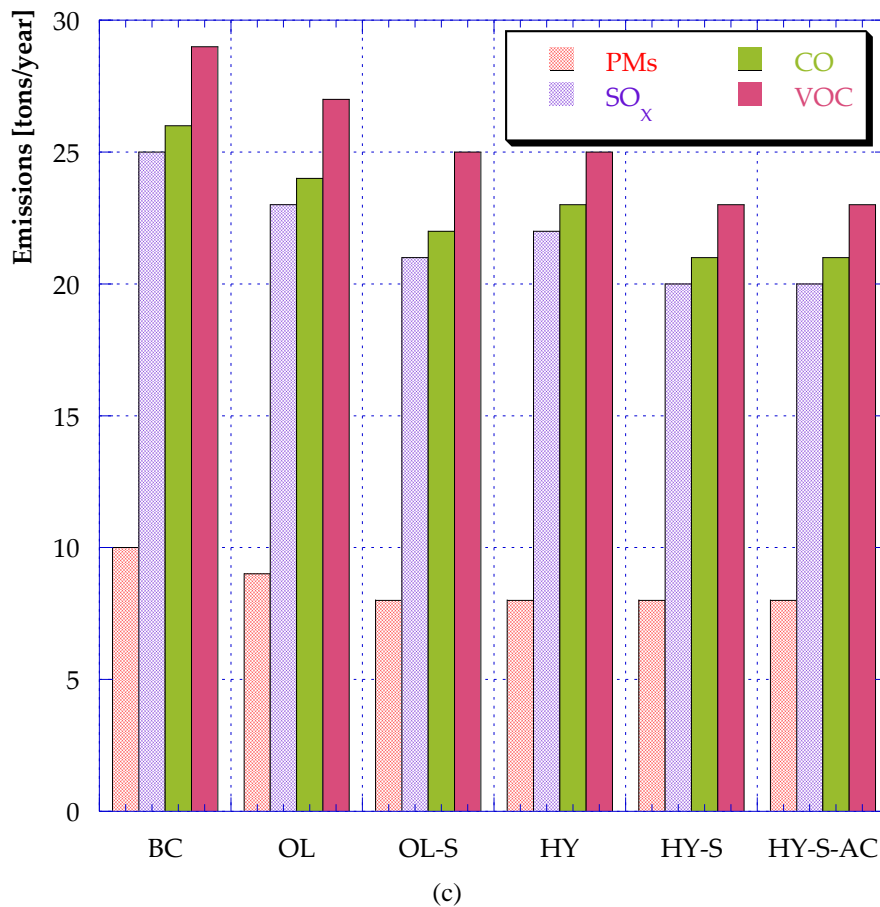
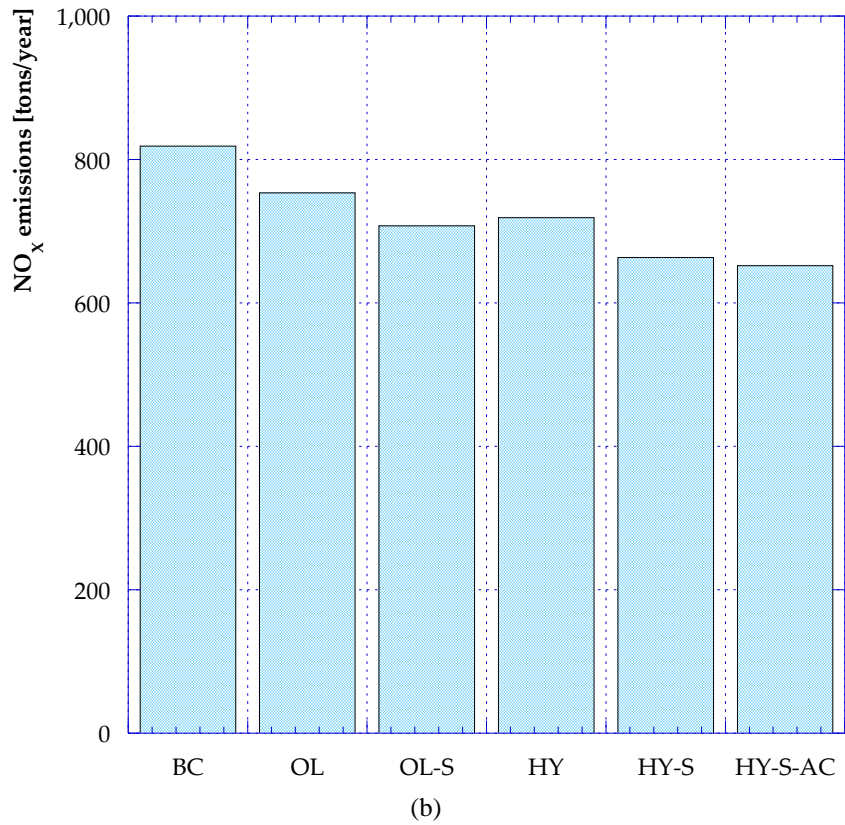

Figure 21 – Main pollutant emissions: (a) CO₂, (b) NO_x and (c) CO, PMs, SO_x, and VOC