

Assessment of the energy performance of a solar/biomass hybrid system for the climatization of small- and medium-scale buildings

Matteo Dongellini^{1*}, Christoph Moser², Szabolcs Varga³, João Soares³, Claudia Naldi¹ and Gian Luca Morini¹

¹Department of Industrial Engineering, Alma Mater Studiorum - University of Bologna, Italy

²Institute of Thermal Engineering, Graz University of Technology, Austria

³Institute of Science and Innovation in Mechanical and Industrial Engineering, University of Porto, Portugal

Abstract. The H2020 EU-funded project Hybrid-BioVGE aims to develop an efficient system entirely based on solar energy and biomass for the climatization of buildings during both the heating and cooling seasons. The most innovative component of the concept is a solar-driven Variable Geometry Ejector (VGE) cooling cycle, which can adjust its internal geometry with two degrees of freedom, according to the effective operating conditions. This paper presents the components of the Hybrid-BioVGE concept and describes a demonstrator of the proposed solution installed in a single-family house in Porto (Portugal). The main characteristics of the building, the size and typology of thermal energy storages included in the system are presented as well. In order to demonstrate the energy-saving potential of the Hybrid-BioVGE concept, the numerical model of the demonstrator was implemented in the TRNSYS 18 environment. Outcomes of simulations include the system's energy performance for both heating and cooling seasons, the achievable solar fraction and the VGE efficiency. Numerical results show that up to 98% of the system energy input derives from renewable sources, with a solar fraction of 61.5%, during the heating season. On the contrary, the seasonal performance factor in cooling operating mode is lower than expected. The VGE cooling cycle efficiency is mainly penalised by the heat rejection loop, which should be optimised to achieve the best performance.

1 Introduction

In the European Union (EU), the residential building sector accounts for more than 27% of the final energy demand and is responsible for about 24% of greenhouse gas [1]. In order to improve the environmental sustainability of this sector, many countries have set challenging targets to boost the decarbonisation of buildings. For example, the EU has recently approved

* Corresponding author: matteo.dongellini@unibo.it

the amendment of the Renewable Energy Directive [2], which sets a minimum annual increase of renewable energy use in heating and cooling applications for HVAC systems.

Unfortunately, the energy demand for space cooling and air conditioning in buildings is expected to grow significantly due to climate change [3]. Since cooling energy is almost totally provided by electric-driven vapour compression devices, a remarkable increase of electric energy off-take from the grid is likely in the following decades. Within this framework, the recent rise in electricity prices and the adoption of severe environmental regulations make heat-driven refrigeration systems a suitable solution [4]. In particular, solar cooling technologies are particularly interesting due to the intrinsic correlation between the availability of the source and the energy demand for cooling.

Among the other technologies, solar-driven ejector cooling systems have a strong potential for several applications because of their simplicity in construction and installation, low cost and flexibility in the design phase compared to more commercially mature absorption chillers [5]. As pointed out by several papers published in the open literature, solar-driven ejector cycles can be used proficiently in air conditioning systems, especially in the Mediterranean climate, because of their capability to produce refrigerated water in the range of 10-15 °C from a low-grade external source such as solar energy. For example, Pollerberg et al. [6] studied experimentally the performance of an ejector cycle driven by parabolic trough collectors, which uses water as the working fluid. The system's annual performance was calculated with a quasi-dynamic numerical model for different European and North African locations. The results showed the system's cost-effectiveness for the Egyptian climate.

Despite the promising potential of this technology, only a few pilot-scale installations are present nowadays. Ejector-based chillers are characterized by a relatively low efficiency: typically, the coefficient of performance (*COP*) of a solar-driven ejector cycle is lower than 0.3 and, furthermore, its failure for high values of the ambient temperature and is frequent [7]. Many studies have been devoted to improving the performance of solar-driven ejector cooling systems to overcome these drawbacks.

Among the others, the ejector geometry was identified as the most influencing parameter in a solar-driven ejector cooling system. For a given working fluid, the optimal geometry of the device depends strongly on the operating conditions; consequently, a fixed-geometry ejector can work with high performance only in a narrow range of working temperatures/pressures. Therefore, a variable-geometry ejector (VGE) would be the best solution to improve the seasonal performance of this kind of systems due to its capability to handle variable operating conditions. In most studies, the nozzle exit position and the ratio between the constant area section and the primary nozzle throat area (i.e., area ratio) were addressed as the most influencing geometric factors [8].

Varga et al. [9] tested a movable spindle at the primary nozzle inlet numerically and experimentally, controlling the area ratio and modifying the nozzle throat area. According to the spindle movement, the primary flow rate could be adjusted. More recently, Ortego Sampedro [10] proposed a range extender based on lateral cylindrical moving slots by means of which the ejector mixing chamber can be varied. The comparison with a reference fixed-geometry ejector, made with a validated CFD model, showed that the system's cooling capacity could be increased up to 120% at low condensing temperatures. Van Nguyen et al. [11] presented the experimental performance of a small-capacity VGE using R600a with active control of the primary nozzle geometry under real operating conditions at a laboratory scale. In the prototype, both the nozzle exit position and the area ratio could be adjusted. The results clearly showed that an optimal configuration of both elements could be identified depending on the working conditions.

Within this framework, the H2020 Hybrid-BioVGE project [12] aims to propose an innovative HVAC system, by means of which the energy needs for space heating/cooling and

DHW production of residential and small-scale commercial buildings can be satisfied with a very high share of renewable energy. The system developed along the project is driven by heat during the year, exploiting two renewable sources: solar energy and biomass. The most innovative element of the system is a thermally-driven VGE chiller. To the best of the authors' knowledge, the cooling cycle described in this work is the first application in which the ejector geometry can be adjusted with two degrees of freedom and with automated logic. Moreover, the main novelty of the present paper is related to the installation of the VGE unit in a real demonstrator: it is believed that the HVAC system described here is the first example of a solar-driven ejector cycle integrated into a residential building for air conditioning.

In this paper, the main features of the demonstrator are described in detail. Then, the HVAC system's annual energy performance is assessed by means of a dynamic simulation model implemented with TRNSYS 18 [13] Figures and tables

Figures and tables, as originals of good quality and well contrasted, are to be in their final form, ready for reproduction, pasted in the appropriate place in the text. Try to ensure that the size of the text in your figures is approximately the same size as the main text (10 point). Try to ensure that lines are no thinner than 0.25 point.

2 The Hybrid-BioVGE concept

The Hybrid-BioVGE concept's design was optimised through numerical simulations. Multiple configurations were tested to achieve the best combination between the different subsystems (e.g., position and typology of thermal energy storage (TES) systems). The final schematic layout of the HVAC system is presented in Figure 1.

Solar energy is the system's primary energy source, obtained from two solar fields installed on the building's pertinence and used directly to meet the energy needs for space heating and DHW production. Solar energy also feeds a heat-driven cooling cycle, which relies on a variable geometry ejector. The VGE chiller has the capability to adjust the ejector geometry according to the effective operating conditions of the system, allowing it to achieve optimal values of its *COP* in a wide range of working conditions (i.e., generation, condensation and evaporation temperatures).

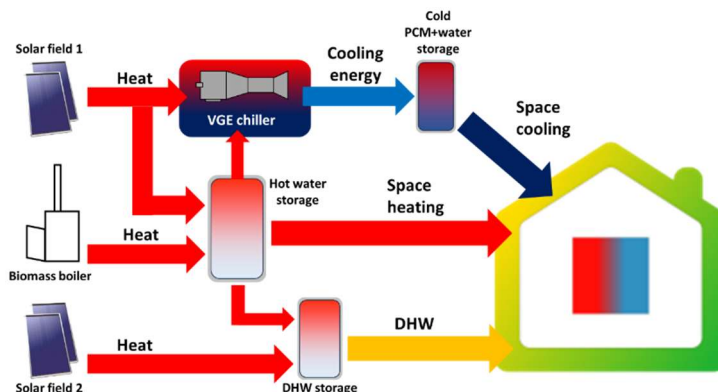

Fig. 1. Schematic of the Hybrid-BioVGE concept for a single-family house.

In order to provide heat when solar energy is absent or scarce, a biomass boiler is used as a backup system. The boiler is based on a novel biomass combustion technology aiming at achieving a strong reduction of NO_x and particle matter emissions with several alternative fuels: wood chips, pellet, woody, agricultural and herbaceous fuels [14]. In this way, the performance of the Hybrid-BioVGE system can be optimised since the backup boiler can be

fed with the cheapest or the most widespread fuel available in the location where the system is installed.

The mismatch between the energy demand from the building and the availability of solar energy is mitigated by a large sensible TES, coupled to solar field 1, by means of which heat can be stored and used to feed the building heating distribution loop during the cold season and the other elements of the HVAC system when needed. A smaller TES, coupled with solar field 2, is adopted to prepare DHW instantaneously. Auxiliary heat is provided by the large hot water TES when the solar source is scarcely available.

During the summer season, cooling energy is provided by the VGE refrigeration unit and is stored within a latent TES tank filled with encapsulated phase change material (PCM) and water. This solution has been substantiated by several simulations and experimental tests [15], showing that storing the cooling energy from the ejector cycle improves the exploitation of solar energy on a seasonal basis.

It is worth mentioning that the Hybrid-BioVGE concept can be adapted and scaled for different types of buildings. For example, the solar field 2 and DHW storage tank can be removed from the layout for tertiary or office applications since the demand for hot water is null or negligible.

3 Design of the Variable Geometry Ejector cooling cycle

The critical component of the Hybrid-BioVGE concept is the ejector-based cooling cycle. The cross-section of a typical ejector for cooling applications is shown in Figure 2. The refrigerant high-pressure primary flow, coming from the generator with a certain degree of superheating, enters the primary nozzle at low velocity. Due to its converging shape, the primary flow is accelerated and choked within the nozzle throat section. Then, the refrigerant is expanded in the divergent section of the primary nozzle and flows in the suction chamber of the ejector with low static pressure and supersonic speed. Since the pressure within the chamber is lower than the evaporator pressure, the secondary flow is drawn from the evaporator into the mixing chamber and gets accelerated.

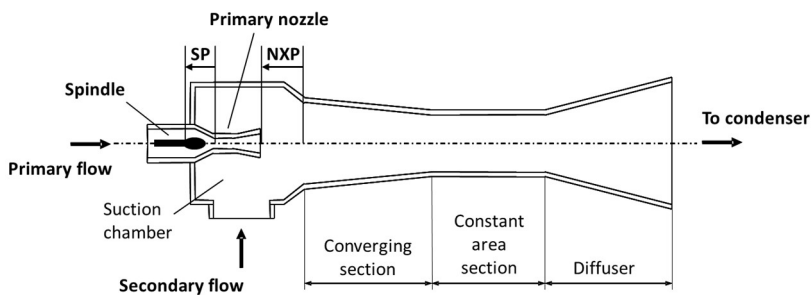

Fig. 2. Schematic layout of the variable geometry ejector developed during the Hybrid-BioVGE project.

Downstream the nozzle exit section, primary and secondary streams start mixing, and pressures of both flows tend to be levelized. Then, the mixing process completes in the constant area section of the ejector, and a final shock wave occurs. Finally, the mixed stream is decelerated in the diffuser section, increasing its static pressure.

In order to widen the ejector operational range and improve the seasonal performance of the chiller, the VGE designed for the Hybrid-BioVGE concept can vary the ejector internal geometry with two degrees of freedom. In particular, the VGE cycle can simultaneously adjust: i. the primary nozzle cross-section area by means of a movable spindle (SP) on the

high-pressure side of the nozzle; ii. the nozzle exit position (NXP) within the ejector converging section. SP and NXP positions can be fine-tuned independently by high-precision linear stepper motors.

A CFD numerical model has been used in this work to optimise the VGE geometry and predict its performance for all operating conditions. First, the ICEM software (ANSYS) was used to generate different numerical meshes, validated using mesh independence tests. Then, the commercial software ANSYS Fluent was adopted to simulate the fluid flow inside the ejector. More than 1500 numerical simulations were performed to determine the distribution of flow properties within the ejector domain (e.g., velocity components, temperature, pressure) and derived quantities, such as the primary and secondary mass flow rates, cooling capacity and maximum critical pressure at the diffuser exit. The ejector geometrical features were designed, including spindle shape, mixing section area and diffuser length, and the full travel length of SP and NXP positions were set. In particular, the spindle position can be adjusted along a path of 20 mm, while the nozzle exit position can be moved along a length of 15 mm.

Once the ejector geometry and flow paths were optimised, the VGE performance was determined by means of CFD simulations in correspondence with all possible working conditions. The most important key performance indicators for an ejector cooling system are the entrainment ratio (ω) and the cooling cycle thermal COP ($COP_{VGE,th}$). ω is calculated as the ratio between the secondary and primary flow mass flow rates. At the same time, $COP_{VGE,th}$ can be obtained as the ratio between the cooling capacity at the evaporator and the heat supplied by the external heat source to the generator.

Table 1 and Table 2 report the values of the VGE entrainment ratio and thermal COP , respectively, as functions of generator, condenser and evaporator temperatures (T_{gen} , T_{cond} and T_{eva} , respectively).

Table 1. VGE entrainment ratio as a function of the operating temperatures.

T_{gen} (°C)	$T_{eva} = 10$ °C		$T_{eva} = 15$ °C	
	$T_{cond} = 30$ °C	$T_{cond} = 40$ °C	$T_{cond} = 30$ °C	$T_{cond} = 40$ °C
76	0.449	0.106	0.646	0.196
85	0.567	0.209	0.786	0.312
94	0.665	0.302	0.899	0.414

Table 2. VGE thermal COP as a function of the operating temperatures.

T_{gen} (°C)	$T_{eva} = 10$ °C		$T_{eva} = 15$ °C	
	$T_{cond} = 30$ °C	$T_{cond} = 40$ °C	$T_{cond} = 30$ °C	$T_{cond} = 40$ °C
76	0.392	0.092	0.570	0.171
85	0.493	0.180	0.692	0.272
94	0.580	0.26	0.793	0.362

The primary stream of the working fluid is pressurised to the required generator pressure by using a variable-speed diaphragm pump controlled by a frequency inverter. Brazed plate heat exchangers were selected as generator, condenser and evaporator. These components were sized according to the design operating conditions on the basis of heat transfer capacity, flow rates, temperature and pressure. Downstream of the condenser, the refrigerant pressure is controlled by an electronic expansion valve. The pressure drop across the valve determines the refrigerant temperature within the evaporator, which can be governed through the VGE controller by adjusting the valve opening. Piping and fittings were selected to minimise the refrigerant head losses and are covered with thermal insulation to reduce thermal losses to the environment. In Figure 3, a schematic representation of the VGE cooling unit is reported.

During the normal operation of the cooling system, the VGE is activated when the building requires cooling energy and two boundary conditions are verified simultaneously: the condenser pressure is below the critical value (depending on both the generator and evaporator pressure), and sufficient thermal power to drive the generator is available. The onboard control logic of the VGE aims to maximise the cooling cycle performance. The positioning of both linear actuators is adapted continuously to the variation of the operating conditions, and optimal values of SP and NXP positions are set.

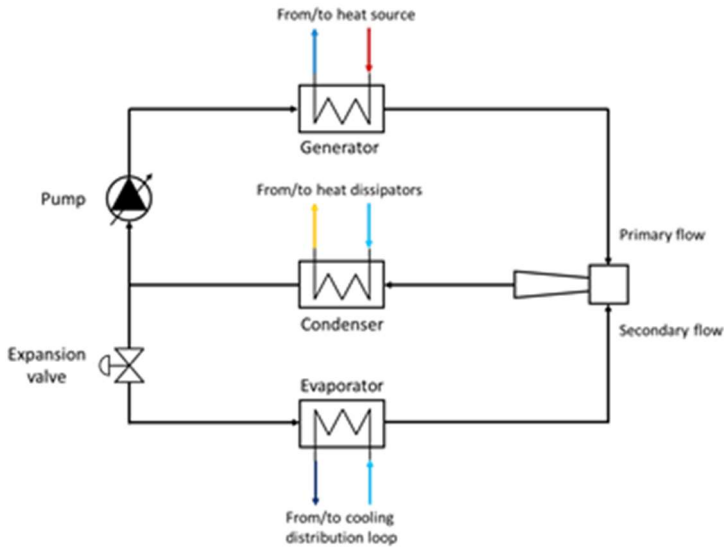

Fig. 3. Schematic of the VGE cooling system with its main components.

4 Description of the Hybrid-BioVGE demonstrator

A demonstrator of the Hybrid-BioVGE concept was designed and installed in a single-family house recently built in Porto (Portugal). In this Section, a short description of the building and the main elements of the HVAC system is provided.

4.1 Single-family residential building



Fig. 4. View from the outside of the demonstrator building.

The single-family house considered in this work was built in Porto in 2019-2020 and is located at an altitude of 87 m and 5 km from the Atlantic Ocean. The demonstrator building presents four storeys: an unheated basement and three conditioned floors (ground floor, first floor and second floor). The building consists of 14 rooms, and the heated zone has a net floor area and a net volume equal to 186.2 m² and 426.7 m³, respectively. Finally, it is worth mentioning that a staircase interconnects the basement, ground floor and first floor. For this reason, an additional air exchange rate between these adjacent storeys was set in the TRNSYS model. A view of the test house is shown in Figure 4 for reference.

The building envelope is characterised by high-quality thermal insulation. Since many components are present in the envelope, in Table 3, the layer structure, thickness and U-value range are summarised for the main typologies of the structural elements (i.e., external and internal walls, floors/ceilings and roof).

Table 3. Structural and thermal properties of the building envelope components.

Envelope component	Layers	Thickness range (cm)	U-value range (W/m ² K)
External wall	Coating, insulation, bricks, plaster	30-35	0.31-0.38
Internal wall	Coating, insulation, plaster	22.5-26	0.39-0.47
Internal floor/ceiling	Concrete, insulation, coating	40.5-45.5	0.34-0.36
Roof	Concrete, insulation, air gap, plaster	35-61	0.33-0.37

Transparent components are made of 4/16/4 double-glazing windows with argon filling in the chamber and PVC frame. The U-value and g-value of windows are equal to 1.67 W/(m² K) and 0.43, respectively. All transparent elements are equipped with Venetian blinds, with a shading factor assumed equal to 0.7.

Thermal energy is supplied to the building zones using two types of emitters. During the heating season, heat is distributed by radiant floor surfaces. Two manifolds, one for the ground floor and one for the first floor, split the hot water stream among 14 loops. On the other hand, space cooling energy demand is provided by 2-pipe hydronic fan-coils. Two larger units and three smaller models are installed on the ground and first floors, respectively.

4.2 Components of the HVAC system

In Figure 5, the layout of the Hybrid-BioVGE system installed in the demonstrator building is represented. The largest share of components is placed in the building's basement (i.e., VGE cooling cycle, biomass boiler, hot water TES and PCM cold TES). At the same time, solar thermal collectors, heat dissipators and the DHW TES are installed on the building's roof.

As pointed out by the scheme in Figure 5, the solar field 1 is decoupled from other components by means of a brazed plate heat exchanger to set a higher pressure within solar collectors. The heat exchanger has 20 plates and a nominal efficiency of 85.6%. On the contrary, the solar field 2 is directly connected to the DHW TES with a coiled heat exchanger immersed in the lower part of the tank.

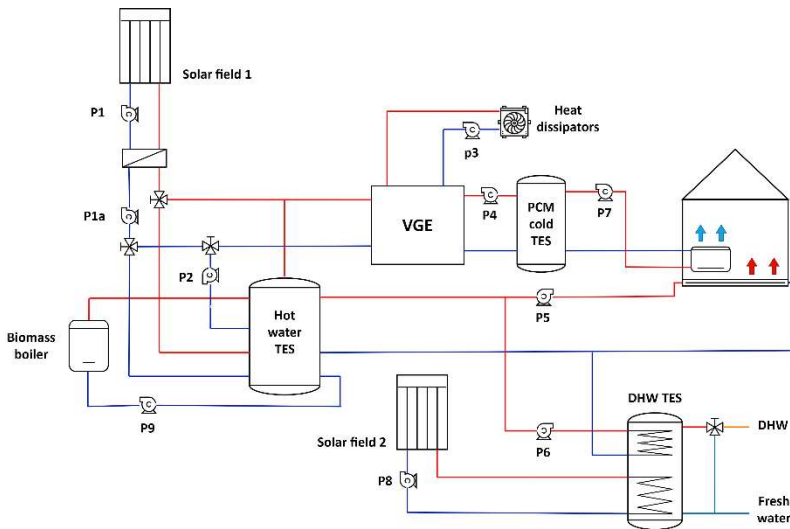

Fig. 5. Layout of the Hybrid-BioVGE system installed in Porto.

Flat plate solar thermal collectors with a gross area of 1.82 m² are used in both solar fields. The optical efficiency of each collector is equal to 0.8586, while first- and second-order loss coefficients are equal to 3.46 W/(m² K) and 0.01 W/(m² K²), respectively. Eleven south-oriented solar thermal collectors with a slope of 35° are installed on the flat roof. The larger solar field 1 presents nine collectors, while only two solar panels are dedicated to DHW production.

A commercial pellet boiler is used as a backup heater during both seasons. The boiler's nominal heating capacity is 12 kW, and its generating efficiency is equal to 94% at full load. The boiler presents an onboard controller that automatically manages start-up, ignition, combustion, cleaning and de-ash processes during the normal operation.

In order to enhance the efficiency of the Hybrid-BioVGE system operation and improve the deployment of solar energy, different thermal energy storages are included in the demonstrator. A sensible hot water buffer tank, having a volume of 1000 litres, is installed in the technical room. As pointed out in Figure 5, the hot water TES has four pairs of ports and is connected to all other system elements. DHW is stored in a 300-l buffer tank, having two immersed coiled heat exchangers. In particular, solar energy is provided directly to the DHW tank by the solar field 2 through the coil installed in the lower part. On the contrary, the coil in the top position is connected to the larger TES to provide heat during cloudy days. Finally, latent-sensible TES stores refrigerated water and decouples the VGE evaporator from the cooling energy distribution loop. The cold storage has a capacity of 600 litres and is filled

with macro-encapsulated rectangular PCM modules (heatSel) for about 33% of its volume. Each element has dimensions 185x185x32 mm and is characterized by an enlarged surface-to-volume ratio. ATS 15, a salt hydrate with a heat storage capacity of 180 kJ/kg and melting and solidification range equal to 12-17 °C and 15-11 °C, respectively, is used in the demonstrator. It is important to stress that the PCM selection depends on the specific application in which the Hybrid-BioVGE system must be installed: the cold TES design (i.e., capacity, position and percentage of filling) can be optimised as a function of the emitter's typology, system control strategy and hydraulics.

Two commercial water-to-air heat dissipators, connected in parallel, are coupled to the VGE condenser to reject condensation heat to the ambient air. The rated dissipating capacity of each unit is equal to 54.4 kW, evaluated for ambient temperature equal to 15 °C, inlet and outlet water temperature equal to 85 °C and 75 °C, respectively. Moreover, the electric power input of the fan installed in each heat dissipator is equal to 180 W at full load. It is important to stress that the performance of heat dissipators is dramatically influenced by the operating conditions. Technical data provided by the manufacturer show that the dissipating capacity of each unit drops to 15 kW for working conditions typical of the cooling season (i.e., ambient air temperature and inlet water temperature equal to 25 °C and 50 °C). Furthermore, the heat rejection capacity of the units decreases to 10 kW in correspondence to the design ambient temperature for Porto (i.e., 35 °C).

The electric power absorbed by the VGE cooling cycle and ten circulating pumps installed within the HVAC system have been considered to evaluate the overall energy performance of the demonstrator. More in detail, experimental tests carried out previously on the VGE chiller indicate that when the device is in stand-by mode and regular operation, the electric power input is equal to 40 W and 350 W, respectively. Moreover, the rated electric power input of the pumps is equal to almost 355 W.

4.3 Key Performance Indicators of the Hybrid-BioVGE demonstrator

In a solar-driven cooling system, the main KPI is the Solar Fraction (SF), defined as the percentage of the system's total energy input provided by solar energy. In order to analyse the energy performance of the system over the year, the solar fraction is calculated separately for the heating and cooling period (SF_h and SF_c , respectively) according to the following Equations:

$$SF_h = Q_{sol,h} / (Q_{sol,h} + Q_{boil,h}) \quad (1)$$

$$SF_c = Q_{sol,c} / (Q_{sol,c} + Q_{boil,c}) \quad (2)$$

where $Q_{sol,h}$ and $Q_{sol,c}$ are the solar energy collected by solar thermal panels of both solar fields during the heating and cooling season, respectively, $Q_{boil,h}$ and $Q_{boil,c}$ are the heat delivered by the biomass boiler during the heating and cooling period, respectively.

In order to evaluate the VGE cooling cycle energy performance, the VGE Seasonal Performance Factor (SPF) was introduced. This KPI can be defined as the ratio between the useful cooling energy delivered by the evaporator and the energy input of the device. Since the VGE is driven by two different sources, two indicators were introduced, depending on the considered energy vector (i.e., heat to drive the generator and electric energy for the VGE internal components, generator, condenser and evaporator pumps and heat dissipators' fans):

$$SPF_{VGE,th} = Q_{eva} / Q_{gen} \quad (3)$$

$$SPF_{VGE,el} = Q_{eva} / W_{el,VGE} \quad (4)$$

In Equations 4 and 5, $SPF_{VGE,th}$ and $SPF_{VGE,el}$ are the VGE seasonal performance factors referred to thermal and electrical energy input, respectively, Q_{eva} and Q_{gen} are the cooling energy supplied by the chiller to the cold TES and the heat provided to the VGE generator during the cooling season, and $W_{el,VGE}$ is the electric energy input of the VGE cooling unit and its auxiliaries.

5 Results and discussion

Since the Hybrid-BioVGE demonstrator was installed recently and the monitoring period has just started, the system’s energy performance was calculated numerically using a dynamic simulation model implemented in the TRNSYS 18 environment. The simulations were performed for the whole year, with a time step of 5 minutes, considering the typical meteorological year of Porto. According to climatic data and the current regulations, the heating and cooling seasons were set between the 27th of October and the 30th of April and from the 1st of May to the 26th of October, respectively.

5.1 Heating operating mode

The energy balance of the Hybrid-BioVGE system during the heating season is shown in Figure 6. Numerical results confirm the potential of the Hybrid-BioVGE concept during the heating season for Porto's climate. As pointed out by data reported in Figure 6, the largest share of the system energy input is provided by solar energy. The system solar fraction is equal to 61.5%, a value higher than the expected target for locations characterised by a predominant cooling load climate. Both solar fields collect about 3900 kWh of thermal energy during the heating period to satisfy the building energy demand for space heating and DHW production. Over the same period, the biomass boiler provides auxiliary heat for about 2500 kWh, corresponding to a wood pellet consumption of almost 650 kg.

Numerical results point out that the Hybrid-BioVGE system supplies the entirety of the requested thermal energy for space heating and hot water preparation, equal to 3321 kWh and 2273 kWh, respectively. Moreover, it is worth mentioning that heat losses from piping and thermal energy storages ($Q_{loss,h}$) are limited to 740 kWh, corresponding to a percentage lower than 15% of the overall thermal energy provided to the building over the season. Finally, a minimal electric energy consumption linked to circulating pumps and auxiliaries is achieved. The total electric energy needed for the HVAC system is equal to 89 kWh, corresponding to a negligible share, lower than 2% of heat supplied to the building.

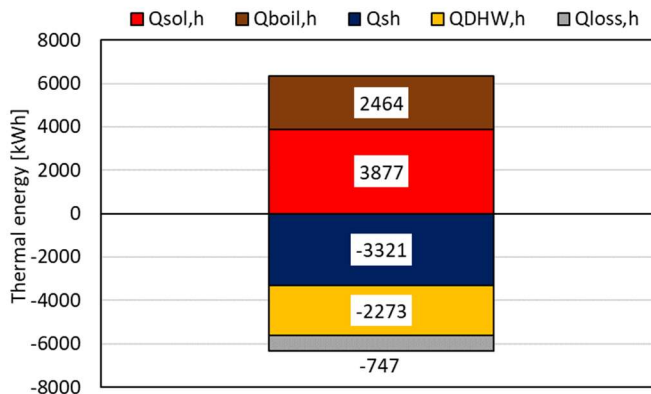

Fig. 6. Energy balance of the Hybrid-BioVGE system during the heating season.

5.2 Cooling operating mode

The seasonal energy performance of the VGE cooling cycle and the energy balance of the whole Hybrid-BioVGE system are shown in Table 4 and Figure 7, respectively. Numerical results show that the system energy performance is much lower than expected during the cooling season. In fact, the system solar fraction SF_c is limited to 44% over that period. Solar fields collect less than half of the overall energy input, and the biomass boiler must provide a significant amount of auxiliary heat. The wood pellet consumption is equal to almost 1500 kg, about ten times higher than expected.

Table 4. Seasonal energy performance of the VGE cooling cycle.

Q_{gen} (kWh)	Q_{eva} (kWh)	Q_{cond} (kWh)	$W_{el,VGE}$ (kWh)	$SPF_{VGE,th}$	$SPF_{VGE,el}$
6526	941	7468	470	0.144	2.00

The analysis of numerical results indicates that the critical element of the Hybrid-BioVGE demonstrator is the VGE cooling unit, characterised by a very limited efficiency. As pointed out in Table 4, the thermal and electrical seasonal performance factors of the VGE are very low and equal to 0.144 and 2.00, respectively. The performed simulations show that the heat rejection loop penalises the VGE performance significantly. As mentioned before, the efficiency of heat dissipators is dramatically reduced for high values of the ambient air temperature. Therefore, the refrigerant condensation temperature increases beyond 30 °C for the largest share of the cooling season, and the chiller operates with a poor COP , lower than 0.2, even for high generation temperatures. Furthermore, when the condensation temperature increases to 40 °C, the chiller is switched off because critical conditions cannot be reached. Due to this intermittent and unexpected operation, the building cooling energy demand cannot be satisfied entirely. Results from numerical simulations show that only 60% of the space cooling energy need can be provided by the Hybrid-BioVGE system, resulting in overheating within the building rooms and thermal discomfort for the tenants.

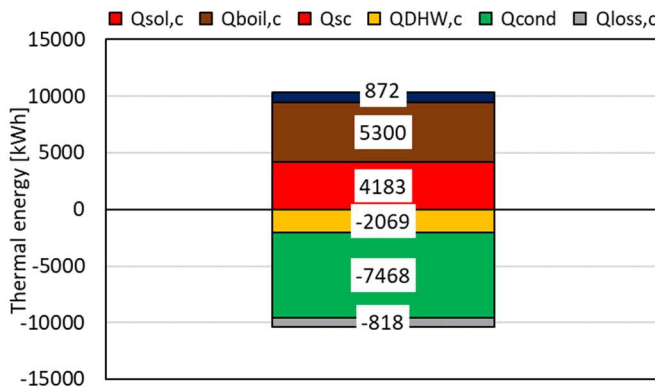

Fig. 7. Energy balance of the Hybrid-BioVGE system during the cooling season.

Moreover, the cooling cycle's generation loop can also be optimised. Numerical results indicate that the VGE cannot be driven directly by solar field 1 since stagnation is frequently reached during sunny days. The hot water TES is charged rapidly by solar thermal collectors during the morning of a typical summer day, and stagnation is observed until the evening. In fact, no cooling load is present in the first part of the day, and the HVAC system does not require heat. Then, when the building's thermal zones need cooling energy in the following

part of the day, the chiller can be driven only by the hot storage tank. Therefore, the VGE operates with a limited generating temperature even for optimal condensation temperatures since the maximum water temperature allowed in the tank is equal to 95 °C.

Furthermore, the low cooling capacity at the VGE evaporator, due to the very low *COP* of the cooling cycle, results in a prolonged operation of the chiller to meet the building cooling energy demand. Therefore, the electric energy consumption of the cooling unit auxiliaries (and, consequently, of the whole system) is much higher than expected. Data from Table 4 show that $W_{el,VGE,tot}$ is equal to 470 kWh, corresponding to about 50% of the cooling energy supplied to the building.

To summarise, the results of dynamic simulations outline that the VGE cooling cycle energy performance is penalised strongly by the incapability to dissipate the condensation heat to the ambient properly. For this reason, the heat dissipation loop must be redesigned to maximise the Hybrid-BioVGE concept's benefit. For example, the availability of warm water streams to be used directly in the VGE condenser could significantly improve the system's energy performance.

6 Conclusions

In this paper, the main features of the HVAC system proposed by the H2020 Hybrid-BioVGE project are presented. Solar energy and biomass are the primary energy sources of the system, which provides space heating, space cooling and DHW production for small- and medium-scale buildings. Based on a Variable Geometry Ejector (VGE), a thermal-driven cooling unit supplies refrigerated water during the summer. The VGE can adjust its geometry according to the effective operating conditions by varying the primary nozzle cross-section area and the nozzle exit position independently and automatically by means of an onboard controller, which optimises the ejector operation.

In order to show the potential energy performance of the system, a demonstrator was designed and installed in a single-family house located in Porto (Portugal). The HVAC system presented in this paper is the first example of a VGE cooling cycle integrated into a real application. Since the on-site monitoring of the Hybrid-BioVGE system has started recently, the achievable seasonal energy performance was assessed numerically by means of a dynamic simulation model implemented in TRNSYS 18.

Numerical results clearly show the strong potential of the Hybrid-BioVGE concept for the winter climatisation of buildings in the Mediterranean climate. More than 60% of the overall energy input is provided by solar energy, and the electric energy consumption of auxiliaries is below 2% of the building energy demand for space heating. On the contrary, the system's energy performance during the cooling period is much lower than expected and needs to be improved. The thermal and electrical seasonal performance factors of the VGE are equal to 0.144 and 2.00, respectively, similar to those achievable by a fixed-geometry ejector cycle. Moreover, the building's cooling energy demand is not satisfied entirely due to the VGE's frequent intermittent operation. The analysis of simulation results points out that the heat rejection loop is the critical feature affecting the VGE performance. The dissipator units considered in the concept cannot reject entirely the condensation heat for a significant part of the summer. Consequently, the condensation temperature rises, and the VGE efficiency decreases significantly.

In conclusion, the innovative concept proposed by the Hybrid-BioVGE project is a promising solution to increase the deployment of renewable energy in buildings. Nevertheless, the heat rejection from the VGE cycle condenser must be re-designed to optimise the system's seasonal efficiency in cooling mode.

This paper has been supported by the European Union's Horizon 2020 research and innovation programme under grant agreement N° 818012, project Hybrid-BioVGE (Hybrid Variable Geometry Ejector Cooling and Heating System for Buildings Driven by Solar and Biomass Heat). M. Dongellini acknowledges the support from the European Union – PON Ricerca e Innovazione 2014-2020 ai sensi dell'art. 24, comma 3, lett. a), della Legge 30 dicembre 2010, n. 240 e s.m.i. e del D.M. 10 agosto 2021 n. 1062.

References

1. C. Naldi, M. Dongellini, G.L. Morini, E. Rossi di Schio, The adoption of pressure independent control valves (PICVs) for the simultaneous optimization of energy consumption and comfort in buildings. *En. and Build.* **287**, 112969 (2023)
2. European Parliament, Directive (EU) 2023/2413 of the European Parliament and of the Council of 18 October 2023 amending Directive (EU) 2018/2001, Regulation (EU) 2018/1999 and Directive 98/70/EC as regards the promotion of energy from renewable sources, and repealing Council Directive (EU) 2015/652. *Of. J. of the EU* (2023)
3. R. Mutschler, M. Rudisuli, P. Heer, S. Eggimann, Benchmarking cooling and heating energy demands considering climate change, population growth and cooling device uptake. *Ap. En.* **288**, 116636 (2021)
4. M. Mastrowski, J. Smolka, D. Butrymowicz, L. Antczak, J. Gagan, K. Smierciew, Experimental validation of the theoretical ejector model in a low-grade waste heat refrigeration system using R1233zdE as a working fluid, *Ap. Th. En.* **236**, 121716, (2024)
5. Y. Allouche, S. Varga, C. Bouden, A.C. Oliveira, Dynamic simulation of an integrated solar-driven ejector based air conditioning system with PCM cold storage. *Ap. En.* **190**, 600-611 (2017)
6. C. Pollerberg, A.H.H. Ali, C. Dotsch, Solar driven steam jet ejector chiller. *Ap. Th. En.* **29**, 1245-1252 (2009)
7. A. Anand, A. Gupta, S. Tyagi, Solar cooling systems for climate change mitigation: A review, *Ren. Sust. En. Rev.* **41**, 143–161 (2015)
8. J. Yan, W. Cai, Y. Li, Geometry parameters effect for air-cooled ejector cooling systems with R134a refrigerant, *Ren. En.* **46**, 155-163 (2012)
9. S. Varga, A.C. Oliveira, X. Ma, S. Omer, W. Zhang, S. Riffat, Experimental and numerical analysis of a variable area ratio steam ejector, *Int. J. Ref.* **34(7)**, 1668-1675 (2011)
10. E. Ortego Sampedro, A new variable mixing chamber ejector: CFD assessment, *Ap. Th. En.* **208**, 118242 (2022)
11. V. Van Nguyen, S. Varga, J. Soares, V. Dvorak, A.C. Oliveira, Applying a variable geometry ejector in a solar ejector refrigeration system, *Int. J. Refr.* **113**, 187–195 (2020)
12. European Union, Hybrid-BioVGE - Hybrid Variable Geometry Ejector Cooling and Heating System for Buildings Driven by Solar and Biomass Heat. H2020 project, <https://cordis.europa.eu/project/id/818012/it> (2020)
13. S.A. Klein, W.A. Beckman, J.W. Mitchell, J.A. Duffie, N.A. Duffie, T.L. Freeman, TRNSYS 18: a transient system simulation program: mathematical Reference, 4, Solar Energy Laboratory, University of Wisconsin-Madison, USA (2018)
14. G.A.R. Archan, R. Scharler, M. Buchmayr, N. Kienzl, C. Hochenauer, J. Gruber, A. Anca-Couce, Minimisation of inorganic particulate matter emissions with a novel

- multi-fuel combustion technology that enhances inorganic retention in a compact updraft fixed-bed. *Fuel* **318**, 123611 (2022)
15. C. Moser, A. Heinz, PCM Experiments (Version v1) [Data set]. Zenodo, <https://doi.org/10.5281/zenodo.6602520> (2021)