

# A Comparative Safety Assessment of Hydrogen Storage Tanks for Hydrogen-Powered Buses

Alice Schiaroli, Giordano E. Scarponi\*, Valerio Cozzani

Alma Mater Studiorum – Università di Bologna, Dipartimento di Ingegneria Civile, Chimica, Ambientale e dei Materiali, via Terracini 28, 40131 Bologna, Italy  
[giordano.scarponi@unibo.it](mailto:giordano.scarponi@unibo.it)

Hydrogen is a promising zero-emission fuel that could play a key role in the transition towards a more sustainable economy. It is regarded as a possible fuel for the future that could replace traditional fossil fuels and reduce the consequent amount of greenhouse gas emissions. In contrast with the undeniable benefits introduced by the use of hydrogen as a fuel, its hazardous properties rise concern from the safety standpoint. A potential loss of integrity of the storage equipment might lead to severe consequences such as fires and explosions. The current investigation aims at quantifying the impact of the outcomes of an unexpected hydrogen release from the storage vessels designed for hydrogen-powered buses. A comparative analysis is carried out considering the different conditions in which hydrogen is currently stored on board: as a high-pressure gas, as a cryogenic liquid or as a cryo-compressed gas. According to the operating conditions, a set of accident scenarios that may follow the release of hydrogen is identified and an event tree analysis is carried out to determine the resulting dangerous phenomena. The impact of such phenomena is assessed in terms of damage distances. The results of the study demonstrate the high hazardousness of cryo-compression and highlight that liquid and compressed hydrogen are the preferable solutions from a safety standpoint.

## 1. Introduction

Public transport is a key research area and one of the greatest challenges in the energy transition process. In comparison with other economic sectors, like industry and agriculture, transportation is proved to be the major contributor to greenhouse gas (GHG) emissions (Kazancoglu et al., 2021), with road transport being the biggest source of air pollution (Kijewska et al., 2019). The decarbonization of the sector is crucial to break its strong dependence on hydrocarbon-based fuels and reduce the linked consequences. In this perspective the introduction of hydrogen as a fuel is a recurrent theme. Many projects worldwide are currently focused on the deployment of hydrogen-powered fuel cell buses (FCBs) fleets (Hua et al., 2014) because, given their operational flexibility and abundance, they are the most common means of public transport (Pyza et al., 2022). One of the most significant barriers preventing the spread of hydrogen in vehicles is the need of an efficient on-board storage technology (Hosseini and Butler, 2020). On-board hydrogen storage vessels must be small and lightweight systems to comply with space and mass weight constraints. This is particularly challenging because of the low density of the fuel (Durbin and Malardier-Jugroot, 2013). At present, hydrogen-powered buses are typically equipped with high pressure storage tanks (Hwang H.T. and Varma A., 2014) made of composite materials and wrapped (fully or partially) with a metallic (Type III) or polymeric (Type IV) liner. The fuel is compressed at 350 or 700 bar and stored in 5-8 cylinders with a mass capacity of 8-5 kg<sub>H2</sub> for a total of around 40 kg<sub>H2</sub>, that assures a driving range of approximately 500 km (Ahluwalia R.K. et al., 2018). A valid emerging alternative is liquid hydrogen, stored in thermally double-insulated cryogenic vessels. However, despite the benefit of the significant volumetric density increase, up to 71 kg/m<sup>3</sup>, this solution is not frequently used for several reasons. The main issue is the inevitable formation of the boil-off gas (BOG) that causes efficiency and cost penalty (Hwang and Varma, 2014). With the aim of combining the benefits of both storage solutions (cryogenic and compressed) and overcoming the critical drawbacks, studies on hydrogen physical storage have shifted to a combination of the two methods, the cryo-compression. Cryo-compressed tanks are designed to

operate at high pressures and low temperatures and are suitable for both liquid and gaseous hydrogen storage. Moreover, they have already been successfully tested for fuel cell applications (Ahluwalia R.K. et al., 2018). In addition to the technological aspects, hydrogen properties have raised safety concerns about accidental leaks from vehicles and the related consequences (Abohamzeh et al., 2021). Compared with traditional hydrocarbon fuels, hydrogen has a higher flammability hazard (Crowl and Jo, 2007) due to the lower ignition energy (around one order of magnitude lower) and the wider flammability range (4-75% against 4.4-17% for methane and 1-7.6 for gasoline). Depending on the storage conditions, the presence of ignition sources, and the level of confinement, different final accident scenarios like fires and explosions can arise from the unexpected release of the fuel. The deployment of effective safety measures relies on the knowledge of the consequences and risks of such events, that can be predicted and estimated through the application of risk analysis tools. The present study is aimed at evaluating the consequences, in terms of damage distances, of a hydrogen release from a storage tank designed for hydrogen-powered buses as a consequence of a road crash. The analysis is carried out considering the storage alternatives previously described.

## 2. Methodology

Damage distances are evaluated adapting a procedure based on a methodology proposed by Scarponi et al. (2016). The method consists of five consecutive steps, and it is briefly schematized in Figure 1.

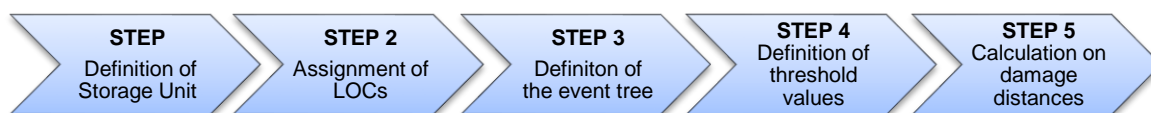

Figure 1: Flowchart of the methodology used for the safety assessment of hydrogen storage vessels for hydrogen-powered buses

The first step is the definition of the Storage Unit (SU) and consists into the determination of the volume, the hydrogen mass inventory and the operating conditions (i.e. temperature and pressure) of the storage tank. In step 2 credible Loss of Containment events (LOCs) are assigned to each SU. Then, the final events (FEs) deriving from each LOC are identified, by means of an event tree analysis, considering all the possible outcomes of the releases (step 3). Next, in step 4, threshold values for the effects of FEs are defined based on the level of damage of interest (i.e. 1% mortality level for a human being exposed to the effect of the dangerous phenomenon considered) according to Tugnoli et al. (2007). Finally, step 5 is the calculation of damage distances, defined as the maximum distances at which the effect of FE matches the relevant threshold. In the present analysis, this last step was carried out using the software PHAST 8.4 DNV.

## 3. Case study

For the present study, vessels containing high pressure (CH<sub>2</sub>), cryogenic liquid (LH<sub>2</sub>) and gaseous cryo-compressed hydrogen (CCH<sub>2</sub>) are investigated, for a total of six tanks. Storage conditions are chosen based on the available information for commercial vessels in use for FCBs: CH<sub>2</sub> is typically stored at 350 or 700 bar at ambient temperature, while LH<sub>2</sub> is in saturated conditions. For gaseous CCH<sub>2</sub>, different combinations of pressure and temperature levels are possible: 350 bar and 339.15 °C, 500 bar and 345.15 °C, 700 bar and 351.15 °C (Ahluwalia R.K. et al., 2018). The calculation is carried out considering two reference sets of tanks. In the first set (referred to as R<sub>m</sub> in the rest of the document), all tanks are assumed to store the same inventory in terms of hydrogen mass. The reference value for the fuel mass is set to 7.79 kg<sub>H<sub>2</sub></sub>, which is close to the maximum capacity of 5-8 kg<sub>H<sub>2</sub></sub> typically available on the market for high-pressure vessels (see Section 1). In the second set (referred to as R<sub>c</sub> in the rest of the document) the most common commercial configuration is considered for each tank. No data for liquid cryogenic hydrogen vessels for hydrogen-powered buses were found in literature. Thus, commercial tank produced for heavy trucks is considered in the analysis. The specifications for the six vessels in the reference set R<sub>c</sub> are summarized in Table 1. Cryogenic liquid hydrogen is assumed to be in saturated conditions at -250 °C. Furthermore, due to the BOG formation, the analysis considers that the LH<sub>2</sub> tank is not completely full of liquid phase: as suggested in (Aziz M., 2021), it is assumed that the liquid occupies 85% of the tank volume.

Table 1: Specifications of commercial vessels for on-board hydrogen storage on hydrogen-powered buses

Storage solution	Physical state	Temperature (°C)	Pressure (bar)	Fuel mass inventory (kg <sub>H2</sub> )
C_350	Gaseous	20	350	4.96
C_700	Gaseous	20	700	7.4
L	Liquid	-250	P <sub>sat</sub> (2.13 bar)	40
Cc_350	Gaseous	339.15	350	9.05
Cc_500	Gaseous	345.15	500	10.53
Cc_700	Gaseous	351.15	700	12.21

Based on the indications provided by the TNO “Purple Book”, a set of three credible LOCs for pressurized road tankers is assigned to each storage vessel. The LOCs selected for this analysis are:

- Catastrophic failure (LOC 1) with consequent instantaneous release of the entire tanks content;
- Continuous leak from a 10 mm hole (LOC 2);
- Continuous leak following the full-bore rupture of a tank connection pipe considering a pipe diameter of 25 mm (LOC 3).

As mentioned before, both liquid and vapor phase are present in LH2 tanks. Given LOCs 2 and 3, the state of the released hydrogen depends on the location of the hole/pipe on the storage tank. Thus, FEs are identified, and damage distances are calculated for both cases. After the LOCs assignment, an event tree describing the chain of events leading to all the possible outcomes (FEs) is obtained for each of them. As an example, Figure 2 shows the event tree obtained for the instantaneous release of the entire tank content (LOC 1), illustrating how this can generate a Vapor Cloud Explosion (VCE) or a fire (Flash Fire, Pool Fire and Fireball) depending on the presence of an ignition source and the level of confinement. Similarly, event trees for LOC 2 and 3 were defined (not reported for the sake of brevity), in which the possible FEs are jet fire, flash fire, VCE and safe dispersion of the release hydrogen are reported.

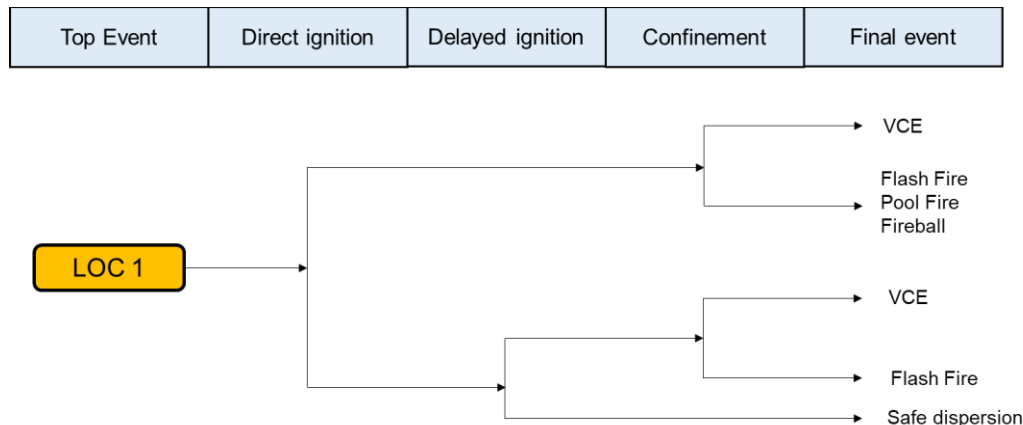

Figure 2: Event tree for an accidental hydrogen release in case of catastrophic rupture of the storage tank (LOC 1)

Then, threshold values for the effects of the possible final accident scenarios are fixed (Table 2). Finally, the software PHAST 8.4 is used to calculate the damage distances for all FEs. Damage distance values are calculated at 1 m from the ground level, which is the typical height where human targets are present. Stable atmospheric (Pasquill's class F) conditions and a low wind speed of 1.5 m/s are set to obtain conservative results. In a common hydrogen-powered bus the storage tanks are located on the roof of the vehicle. Here, the road crash is supposed to cause the overturn of the bus so that the final height of the storage vessels (i.e. the release height) is 1 m. The continuous release scenarios (LOC 2 and 3) are simulated as holes directly in the tank. This assumption neglects the pressure drops for the released stream, providing conservative results.

Table 2: Threshold values for the effects of the possible final accidental scenarios (Tugnoli et. al 2007)

Scenario	Threshold value
Fireball, Jet Fire, Pool Fire	7 kW/m <sup>2</sup>
Flash Fire	½ LFL
Vapor Cloud Explosion	14 kPa

#### 4. Results and discussion

Results are presented as damage distances for each LOC defined in Section 3. Starting from the catastrophic rupture of the tank (LOC 1), Figure 3 shows that liquid cryogenic storage is the most critical solution. The fireball appears to be the worst final event, with damage distances of 21 and 38 m for the Rm and Rc sets respectively. For the CH<sub>2</sub> and CcH<sub>2</sub> storage solutions the calculated distances for the flash fire (around 20 m) are the highest. For a small continuous release (LOC 2), the comparison of the storage alternatives under the assumption of equal mass inventory (Figure 4a) highlights that LH<sub>2</sub> is the best option. Flash fire and explosion values for CH<sub>2</sub> and CcH<sub>2</sub> are comparable, and around 50 m and 20 m respectively. In contrast, the jet fire appears to be particularly harmful for cryo-compressed hydrogen, with distances up to more than 53 m.

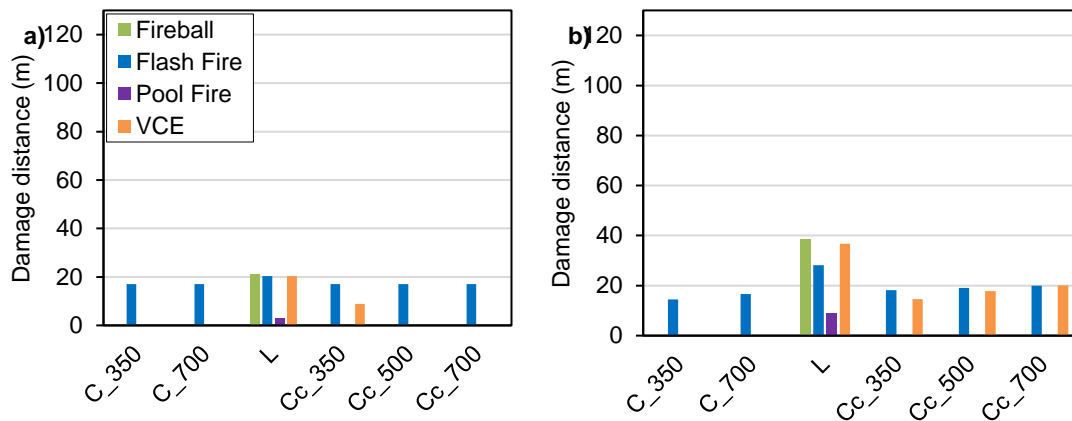

Figure 3: Damage distances in case of catastrophic rupture (LOC 1) for a) reference set Rm (same mass of 7.79 kg<sub>H<sub>2</sub></sub>) and b) reference set Rc.

The comparison among compressed hydrogen tanks shows that, at the same pressure level, the jet fire damage distance calculated for cryogenic storage conditions is almost twice the one obtained for atmospheric temperature tanks. This is true for both the pairs C\_350 vs Cc\_350 and C\_700 vs Cc\_700. This observation is valid for the Rc reference set as well. Again, despite the higher mass inventory, LH<sub>2</sub> can still be considered the best storage solution from a safety standpoint. For this storage condition, the liquid leak is more critical than the release of the vapor phase. For both reference sets, the maximum damage distance for high pressure and cryo-compressed hydrogen is around 50 m. The picture changes when the consequences of the full-bore rupture of the pipe are analyzed. As evident from Figure 5a, for compressed hydrogen the jet fire is the more hazardous outcome, with distances larger than 100 m for CcH<sub>2</sub> tanks. Furthermore, distances for LH<sub>2</sub> are at least twice the values obtained for LOC 2. Differently from all the other storage solutions, where jet fire is the most critical outcome, the worst accident scenario arising from LH<sub>2</sub> is the flash fire. The results of the comparison between CH<sub>2</sub> and CcH<sub>2</sub> at the same pressure level are the same as for LOC 2. In the Rm set, liquid hydrogen is confirmed to be the safest option while the performance of the same tank in the the Rc set shows that the maximum damage distance (around 60 m) of LH<sub>2</sub> and C\_700 is similar in case of liquid release from the first vessel.

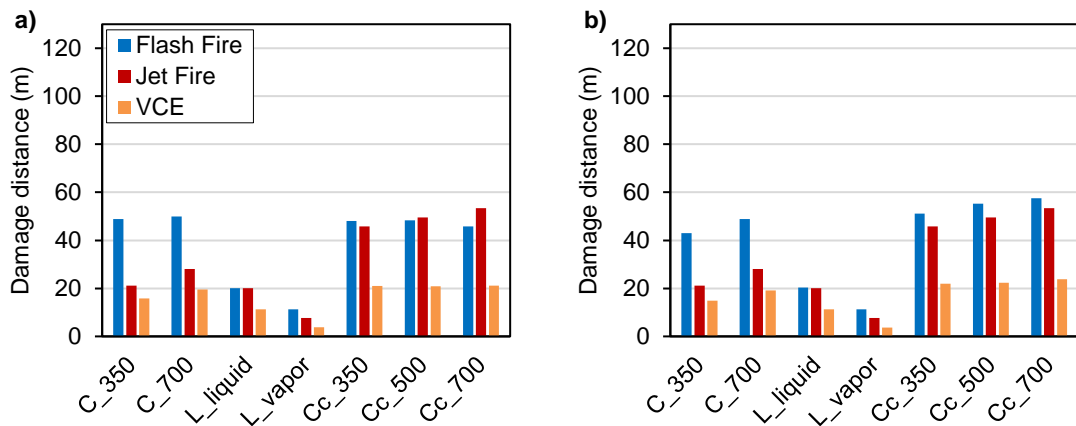

Figure 4: Damage distances in case of leak from a 10 mm hole in the connection pipe (LOC 2) for a) reference set Rm (same mass, mass = 7.79 kg) and b) reference set Rc.

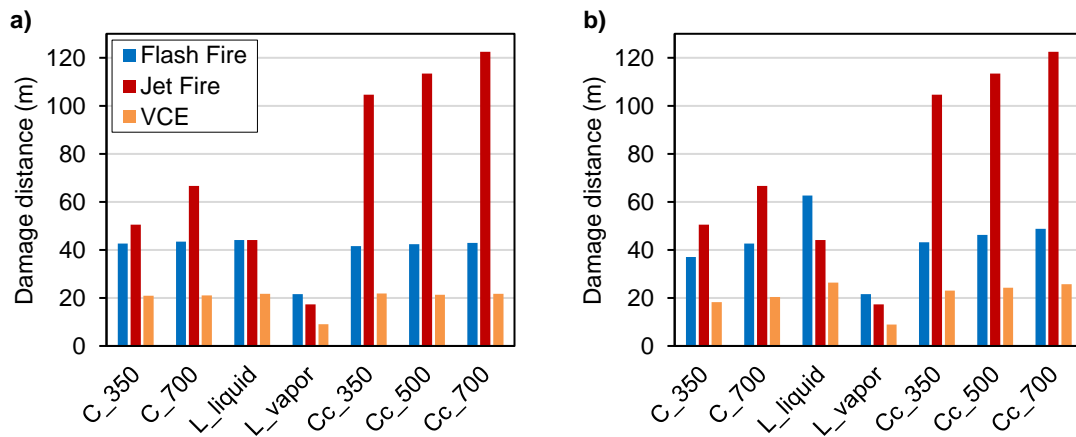

Figure 5: Damage distances in case of leak from a full-bore rupture of the connection pipe (LOC 3) for a) reference set Rm (same mass, mass = 7.79 kg) and b) reference set Rc.

The results obtained in the analysis clearly show that the full-bore rupture of the pipe is the LOC event with the highest potential in terms of damage distances, while the hazardous effects of the catastrophic rupture scenario are limited to short distances. If the analysis is carried out considering the same hydrogen mass for all the vessels (Rm reference set), LH2 could be regarded as the preferable solution because the maximum calculated distance for the tank is less than 32 m (obtained for LOC 1). For the commercial set (Rc), the choice is not so immediate. In fact, the maximum damage distance obtained for the cryogenic liquid tank (63 m) is close to the 67 m and the 51 m obtained for the C\_700 and the C\_350 tanks respectively.

## 5. Conclusions

The present analysis aims at evaluating the outcomes of unwanted releases from road tankers designed for the on-board storage of hydrogen on hydrogen-powered buses. The three most common storage technologies are analyzed, and the results are provided in terms of damage distances calculated for three different LOCs. Overall, the highest damage distances are calculated for the full-bore rupture of the pipe, while the effects of the catastrophic failure vanish at the shortest distances. Even if, at present, compressed hydrogen is the most popular technology, the replacement of the content of a single high-pressure cylinder with liquid hydrogen would give a similar potential damage, but a great reduction of the storage space required. Alternatively, the storage of the entire amount of hydrogen to ensure an acceptable driving range in a single cryogenic container still appears to be feasible and not excessively more hazardous. On the contrary, cryo-compression is at the same

level of hazardousness of CH<sub>2</sub> in case of instantaneous and small continuous releases, but becomes way more critical with larger leaks where jet fire is dominant among the possible FEs. These results are a valid support to assess the safety of hydrogen application on hydrogen-powered buses. The analysis can be extended by making a comparison with the technologies currently in use for various conventional fuels to provide a complete overview and promote risk informed decisions towards the replacement of hydrocarbon energy sources with hydrogen in vehicular applications.

### Nomenclature

C<sub>350</sub> – compressed hydrogen at 350 bar  
 C<sub>700</sub> – compressed hydrogen at 700 bar  
 Cc<sub>350</sub> – cryo-compressed hydrogen at 350 bar  
 Cc<sub>500</sub> – cryo-compressed hydrogen at 500 bar  
 Cc<sub>700</sub> – cryo-compressed hydrogen at 700 bar  
 CcH<sub>2</sub> – cryo-compressed hydrogen  
 CH<sub>2</sub> – compressed hydrogen  
 FE – final event  
 GHG – greenhouse gas  
 LH<sub>2</sub> – liquid hydrogen  
 LOC – loss of containment  
 SU – storage unit

### References

- Abohamzeh E., Salehi F., Sheikholeslami M., Abbassi R., Khan F., 2021, Review of hydrogen safety during storage, transmission, and applications processes, *Journal of Loss Prevention in the Process Industries*, Vol 72, 104569
- Ahluwalia R. K., Peng J.K., Roh H.S., Hua T.Q., Houchins C., James B.D., 2018, Supercritical cryo-compressed hydrogen storage for fuel cell electric buses, *International Journal of Hydrogen Energy*, Vol 43, 10215-10231.
- Aziz M., 2021 Liquid Hydrogen: A Review on Liquefaction, Storage, Transportation and Safety, *Energies* 14, no.18:5917
- Crowl D.A, Jo Y., 2007, The hazards and risks of hydrogen, *Journal of Loss Prevention in the Process Industries*, vol 20, 158-164
- Durbin D.J. and Malardier-Jugroot C., 2013, Review of hydrogen storage techniques for on board vehicle applications, *International Journal of Hydrogen Energy*, Vol 38, 14595-14617
- Hosseini S.E., Butler B., 2020, an overview of development and challenges in hydrogen powered vehicles, *International Journal of Green Energy*, 17:1, 13-37.
- Hua T., Ahluwalia R., Eudy L., Singer G., Jerner B., Asselin-Miller N., Wessel S., Patterson T., Marcinkoski J., 2014, Status of hydrogen fuel cell electric buses worldwide, *Journal of Power Sources*, Vol 269, 975-993
- Hwang H.T., Varma A., 2014, Hydrogen storage for fuel cell vehicles, *Current Opinion in Chemical Engineering*, vol 5, 42-28
- Kazancoglu Y, Ozbiltekin-Pala M., Ozkan-Ozen Y.D., 2021, Prediction and evaluation of greenhouse gas emissions for sustainable road transport within Europe, *Sustainable Cities and Society*, Vol 70, 102924.
- Kijewska K., Iwan S., Korczak J., 2019, Challenges to increase the sustainable urban freight transport in South Baltic Region – LCL project, *Transportation Research Procedia*, Vol 39, 170-179.
- Pyza D., Gołda P., Sendek-Matysiak E., 2022, Use of hydrogen in public transport system, *Journal of Cleaner Production*, Vol 335, 130247.
- Scarponi G.E., Guglielmi D., Moreno V.C., Cozzani V., 2016, Assessment of Inherently Safer Alternatives in Biogas Production and Upgrading, *AIChE Journal*, Vol 62, 2713-2727.
- TNO, 2005, Guidelines for quantitative risk assessment (Purple Book)
- Tugnoli A., Cozzani V., Landucci G., 2007, A consequence based approach to the quantitative assessment of inherent safety, *AIChE Journal*, 53(12), 3171-3182. doi:10.1002/aic.11315