



ALMA MATER STUDIORUM
UNIVERSITÀ DI BOLOGNA

ARCHIVIO ISTITUZIONALE
DELLA RICERCA

Alma Mater Studiorum Università di Bologna Archivio istituzionale della ricerca

Cluster-based Vibration Analysis of Structures with GSP

This is the final peer-reviewed author's accepted manuscript (postprint) of the following publication:

Published Version:

Cluster-based Vibration Analysis of Structures with GSP / Federica Zonzini; Alberto Girolami; Luca De Marchi; Alessandro Marzani; Davide Brunelli. - In: IEEE TRANSACTIONS ON INDUSTRIAL ELECTRONICS. - ISSN 0278-0046. - STAMPA. - 68:4(2021), pp. 3465-3474. [10.1109/TIE.2020.2979563]

Availability:

This version is available at: <https://hdl.handle.net/11585/784697> since: 2023-11-24

Published:

DOI: <http://doi.org/10.1109/TIE.2020.2979563>

Terms of use:

Some rights reserved. The terms and conditions for the reuse of this version of the manuscript are specified in the publishing policy. For all terms of use and more information see the publisher's website.

This item was downloaded from IRIS Università di Bologna (<https://cris.unibo.it/>).
When citing, please refer to the published version.

(Article begins on next page)

This is the final peer-reviewed accepted manuscript of:

F. Zonzini, A. Girolami, L. De Marchi, A. Marzani and D. Brunelli (2021) Cluster-Based Vibration Analysis of Structures With GSP. *IEEE Transactions on Industrial Electronics*, vol. 68, no. 4, pp. 3465-3474

The final published version is available online at:

<https://doi.org/10.1109/TIE.2020.2979563>

Rights / License:

The terms and conditions for the reuse of this version of the manuscript are specified in the publishing policy. For all terms of use and more information see the publisher's website.

This item was downloaded from IRIS Università di Bologna (<https://cris.unibo.it/>)

When citing, please refer to the published version.

Cluster-based Vibration Analysis of Structures with Graph Signal Processing

Federica Zonzini, *Student Member, IEEE*, Alberto Girolami, Luca De Marchi, *Member, IEEE*
Alessandro Marzani and Davide Brunelli, *Senior Member, IEEE*

Abstract—This work describes a divide-and-conquer strategy suited for vibration monitoring applications. Based on a low-cost embedded network of Micro-ElectroMechanical (MEMS) accelerometers, the proposed architecture strives to reduce both power consumption and computational resources. Moreover, it eases the sensor deployment on large structures by exploiting a novel clustering scheme which consists of unconventional and non-overlapped sensing configurations. Signal processing techniques for inter and intra-cluster data assembly are introduced to allow for a full-scale assessment of the structural integrity. More specifically, the capability of graph signal processing is adopted for the first time in vibration-based monitoring scenarios to capture the spatial relationship between acceleration data. The experimental validation, conducted on a steel beam perturbed with additive mass, revealed high accuracy in damage detection tasks. Deviations in spectral content and mode shape envelopes were correctly revealed regardless of environmental factors and operational uncertainties. Furthermore, an additional key advantage of the implemented architecture relies on its compliance with blind modal investigations, an approach which favors the implementation of autonomous smart monitoring systems.

Index Terms—graph signal processing, operational modal analysis, sensor networks, structural health monitoring.

I. INTRODUCTION

THE implementation of vibration-based structural health monitoring (SHM) systems is receiving increasing attention due to the widespread necessity to continuously control the integrity of aging structures [1]–[3]. In the vast field of vibration engineering, solutions built on MEMS accelerometers can be chosen for their suitability to capture dynamic features in quite a broad frequency range [4]. Consequently, the deployment of low-cost and versatile sensor networks,

consisting of miniaturized devices embedding digital signal processing capabilities, has progressively been adopted as a viable strategy compliant with long-term and real-time monitoring [5]–[7].

The analysis of structural vibrations provides a set of modal parameters which characterize its free and forced dynamic response [8]. Since vibration properties are closely connected to the existence of structural damages or faults [9], they can be used to assess the current health status. In this process, synchronization between measurements is fundamental because a lack of synchronicity generates unacceptable phase shifts which strongly impinge on the accuracy of the reconstructed modal features. Authors in Ref. [10] pointed out that the maximum tolerable delay to not alter the accuracy of signal processing outcomes should be inferior to dozens of μ s. Correspondingly, Krishnamurthy *et al.* [11] found that the detrimental effect of synchronicity faults can even exceed the sensor noise or intrinsic oscillations in internal clocks. In particular, it was demonstrated that the major consequences of these uncertainties are associated to higher modes of vibration [12], which are extremely sensitive to time synchronization errors independently from the sensors' positions.

Besides synchronization, the extraction of modal parameters is complicated in large scale or hazardous scenarios, where the high amount of data and sensing devices, combined with the inherent structural complexity and the possible difficulties in powering the sensor network, requires advanced and versatile hardware solutions. In such a context, thanks to their capability to easily adapt to the geometric characteristics of the inspected structure, clustered sensor networks have been gradually developed to reduce the computational and energy budget associated to the gathering of sensor data and their transmission to a central processing unit.

In this work, an energy-efficient and low-cost system is proposed which exploits a network of clustered MEMS sensors to perform modal analysis of vibrating structures. In order to tackle the limitations of state-of-the-art clustered strategies, which consist of overlapped sensor configurations where at least one sampling location is shared among neighboring sub-networks, a novel approach is introduced. In the proposed procedure, vibration data fusion between different, non-overlapped clusters relies on the intrinsic capability of Graph Signal Processing (GSP) techniques to model the inherent geometrical connectivity. Several application fields have recently benefited from this emerging signal representation domain,

F. Zonzini is with the Advanced Research Center on Electronic Systems for Information and Communication Technologies "Ercole De Castro", ARCES, University of Bologna, 40136 Bologna, Italy (e-mail: federica.zonzini@unibo.it)

A. Girolami and L. De Marchi are with the Department of Electrical, Electronic and Information Engineering, DEI, University of Bologna, 40136 Bologna, Italy (e-mail: alberto.girolami2@unibo.it, l.demarchi@unibo.it).

A. Marzani is with the Department of Civil, Chemical, Environmental and Materials Engineering, DICAM, University of Bologna, 40136 Bologna, Italy (e-mail: alessandro.marzani@unibo.it).

D. Brunelli is with the Department of Industrial Engineering, DII, University of Trento, 38123 Trento, Italy (e-mail: davide.brunelli@unitn.it).

including smart cities, traffic networks and environmental processes [13]. The GSP solution presented in this paper overcomes already existing methodologies in terms of energy efficiency and flexibility in the deployment of sensor networks on complex structures. In fact, the achieved reduction of sensing positions lessens the energy demand, supporting more efficient power management strategies. In the sensor network deployment, the advantage is twofold. First of all, since it is based on non-overlapped clusters, the difficulties in wiring sensor nodes on complicated or hazardous scenarios can be easily bypassed. Secondly, as an immediate byproduct of the implemented processing, the minimal cluster size that can be selected is uniquely dictated by the level of structural detail necessary to ensure a reliable inspection process and not by the divide-and-conquer strategy itself.

Furthermore, the proposed approach proves to be robust against operational uncertainties, such as temperature fluctuation and asynchronicity among clusters. Combining the versatility of the circuitry with the advantages of graph signal processing, the resulting system is suitable for different and complex application-fields, revealing to be a competitive alternative to traditional monitoring frameworks.

The paper is organized as follows. The main principles behind vibration analysis are firstly reviewed in Section I. Alongside, a literature survey is reported, describing some of the most representative clustered sensor networks previously proposed for modal investigation. In Section III, the hardware and software characteristics of the developed low-cost architecture, as well as the discussion of its benefits for vibration-based inspection, are presented. The novel GSP-driven vibration analysis procedure and its compliance with structural integrity assessment are illustrated in Section IV, focusing on the correlation between natural frequencies, mode shapes and damage metrics. Section V is dedicated to the experimental validation of the implemented solution. The designed monitoring system was tested on a pinned-pinned steel beam, both in pristine and damaged conditions, where faulty configurations were mimicked by adding a dead mass to the system. Modal parameters extracted from different clusters, consisting of overlapped and stand-alone sensor networks, are investigated, revealing a great level of structural coherence with respect to numerical prediction. Such results strengthen the potential of the proposed graph-based merging strategy to actually represent a valid alternative to already existing methodologies. Finally, conclusions are drawn in Section VI.

II. OMA PRINCIPLES AND RELATED WORKS

Operational Modal Analysis (OMA) targets the reconstruction of the dynamic properties from vibration signals (e.g. accelerations and rotations), and it is considered as a powerful tool to perform real-time and on-condition monitoring of structures exhibiting a vibrating behaviour [8]. The comparison of the actual dynamic features with those extracted in pristine conditions allows the detection of potential damages, thence to estimate their severity and position [14].

The dynamic characterization of structures is defined in terms of modal parameters, among which the set \mathbf{f} of P

natural (modal) frequencies, i.e. the frequency components carrying most of the total structural energy, is very useful for structural integrity characterization purposes. The estimation of natural frequencies is conventionally performed by identifying the dominant peaks appearing in the spectral profile of the gathered data for each sensor of the network. Typically, the extraction of three to five modal components is sufficient in order to detect global changes (e.g. changing load path, loss in global stiffness) [15].

Besides, the specific spatial patterns of vibration exhibited by the monitored structure at the different natural frequencies are usually referred to as modal shapes, which are mathematically arranged as vectors (Φ_p) whose dimension is equal to the number of sensing devices. For the sake of clarity, the modal shape matrix $\Phi = [\Phi_1 \dots \Phi_P]$ is a column-wise entity generated by vertically aligning the modal shapes curves associated to the inspected modes. It is worth noting that, by processing modal shapes, it is possible to implement defect *localization* procedures. In this sense, the information provided by modal shapes is richer w.r.t. the one provided by natural frequencies.

Among the available methods to extract modal parameters, eigenvector-based algorithms, such as the Frequency Domain Decomposition (FDD) [16], simultaneously provide both modal frequencies and shapes. FDD is based on the computation of the Singular Value Decomposition (SVD) of the cross-power spectral density matrix associated to collected data. Alternatively, the Second Order Blind Identification (SOBI) approach can be adopted. SOBI is a strategy which tackles the feature extraction process as a blind source estimation problem. Its fundamentals rely on the assumption that the observed signals are obtained as a linear combination of unknown sources by means of a mixing matrix, whose columns coincide with the sought modal shapes [17].

To be applicable, both SOBI and FDD requires the synchronization of the acquired data. Moreover, high spatial resolution of sensors is beneficial for a precise damage assessment. Therefore, the optimization of computational and communication resources is of the utmost importance. To this aim, three main strategies were presented in the literature [10] for OMA-based SHM scenarios:

- *centralized data processing*: acceleration data acquired at different sensing positions by peripheral sensor nodes are transferred with the proper timestamp to a central processing unit. Either wired sensor networks or complex wireless synchronization protocols are required. This strategy, often adopted in the past for its architectural simplicity, may become unfeasible in current scenarios, where an increasing number of devices are simultaneously connected [18], [19].
- *stand-alone schemes*: each sensor acts both as a sensing and processing unit, hence minimizing the effects of limited bandwidth and communication constraints. Nevertheless, this solution hampers the possibility to perform data cross-correlation between surrounding nodes, thus limiting the possibility to extract structural modal shapes [20].

- “divide-and-conquer” strategies [11], [21]: taking advantage of a hierarchical design, data collection is performed by leaf devices, subsequently forwarding locally elaborated features to a corresponding cluster head (CH). These latter devices execute preliminary processing steps on data pertaining to their controlled area and finally transmit structural parameters to a common aggregating unit, which is used to combine cluster-dependent information and to globally evaluate the structural integrity. Data fusion techniques, feature compression and communication protocols, if effectively combined and customized in such a distributed paradigm, may achieve the best possible compromise between inspection performances and bandwidth [22], [23].

It is worth noting that the last strategy perfectly handles the mode shapes reconstruction process. Specifically, although the processing is performed by multiple sub-networks referred to correspondent sub-structures, the presence of an additional assembly step is crucial to extract the global features of the monitored structure [24]. A plurality of schemes, which differ in terms of topology and task assignment, were implemented obeying to this hierarchical logic. In the following, some of the most noticeable solutions are reviewed, whereas additional examples are extensively described in [25]–[27].

The multilevel cyber-physical system proposed in [28] is based on three main components: (i) cluster members collect raw vibration samples and, after carrying out power spectrum analysis, transmit local modal features to their (ii) CH, which aggregates information concerning its controlled area; finally, (iii) a unique Sink Node (SN) calculates all-embracing modal parameters. A similar, decentralized data aggregation procedure was implemented using a cluster-based wireless sensor network deployed on a truss structure [29]. Analogously, a study of a 14-bay girder was conducted with a two-layered cluster network [23], evidencing a favorable trade-off between the energy requirements and the quality of modal information. Alongside, a multi-channel monitoring architecture was exploited in [30] for the localization of impacts in aircraft composite structures. The hierarchical interoperability of several leaf nodes, few CH nodes and one multi-radio SN enabled the resulting architecture to achieve a reliable global assessment of structural integrity. A different variant of akin configurations is reported in [31], in which the authors implemented a parallel processing architecture based on clusters of sensors which collaborate to compute structural dynamics under the orchestration of a central node. Their solution is characterized by a voting step, necessary to prevent local drifts which may contribute to the misestimation of vibrating frequencies. Conversely, the system in [32] exploits a different distribution of the computational tasks between CHs and a SN. In detail, CHs alone are in charge of feature extraction and decision making about structural health, whereas a SN coordinates them to ensure highly synchronized samples.

In this context, designing a network of partially overlapped clusters is a widely adopted strategy [23], [24] because it leads to two main benefits: i) the possibility to make the monitoring system fault tolerant and resilient; ii) the exploitation of native correlation between sampling points which simplifies the task

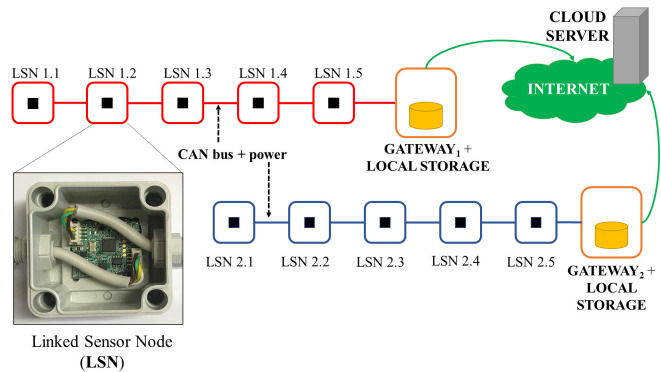

Fig. 1. Example of clustered architecture

of concatenating modal data for the extraction of the global structural signature with minimal data transfer among CHs. Mode shape concatenation in case of overlapped clusters leverages algorithms such as the Post Separate Estimation Rescaling (PoSER) [33]. According to this approach, two consecutive branches can be re-scaled by minimizing in a least-squares sense [34] the discrepancies between modal shape estimations at common reference positions. Other methods have recently been proposed to address the same issue, basing on the second-order statistical properties of measured data, such as [35]. However, all these strategies strictly rely on reference measurement positions shared by multiple clusters, a requirement which represents their main limitation.

In fact, the presence of overlapping sampling positions unavoidably implies an increase in the number of devices to be installed. More importantly, in practical application scenarios it might be impossible to have geometrically overlapped clusters due to the complexity of the structure itself [36]. The development of alternative and more effective solutions should cope with spatially-disjoint sub-networks conformable to the structural characteristics and capable of minimizing both the architectural costs and the electrical and communication constraints.

III. SYSTEM DESCRIPTION

The developed infrastructure includes linked chains of connected sensors forming different clusters, each of them coordinated by a gateway which acts as a corresponding cluster head (Fig. 1). A first and low-level complexity (single cluster) version of the employed architecture was formerly presented in [37], whose topology is upgraded in the present work to be compliant with large-scale and harsh monitoring scenarios.

Three orthogonal axes signals are acquired from LIS344ALH, a MEMS accelerometer with the lowest noise density on its class ($50 \mu\text{g}/\sqrt{\text{Hz}}$). This device is characterized by a maximum band of 1.8 kHz operating in a dynamic range of $\pm 2\text{g}$. The signal acquisition chain is organized as follows. Each Linked Sensor Node (LSN), shown in the bottom left corner of Fig. 1, uses a 32-bit ARM Cortex M4 microcontroller to digitally filter the samples coming from the accelerometer, precisely employing a Finite Impulse Response (FIR) filter implemented with the Floating Point

Unit (FPU), as presented in [38]. Consequently, the gateway collects filtered signals provided by the sensors and forwards data to a cloud server by means of a wireless channel. At this common data-aggregation level, a corresponding virtual sink node is in charge of feature extraction and data merging.

The most relevant functionality of the gateway is the synchronization of the set of peripheral sensors, which are connected through a CAN bus. This protocol is used for the communication from the linked sensor nodes to the CH, allowing for a native synchronization between clocks on different nodes that may have drifts otherwise. Therefore, the CAN bus permits simultaneous acquisitions from the various LNSs at a regular and high data rate of 250 000 baud over 40 m cable; these transmission properties are enough for instrumenting most of the residential and industrial buildings in case of vibration analysis. As such, each cluster automatically embeds its own timestamp and no-coordination between different groups of sensors is still necessary.

In case of civil structures, where principal modal frequencies are typically below 30 Hz, using a data rate of 100 Hz is reasonable for elaborating all the fundamental modes of vibration. Hence, in order to optimize the performances of the circuitry and to meet the same features of expensive piezoelectric accelerometers characterized by a high full-scale to noise-floor ratios, an oversampling strategy with multiplication factor of 256 was implemented. In this way, the 12-bit analog-to-digital conversion (ADC) resolution of the microcontroller unit was improved up to 16-bit, correspondingly incrementing the signal to quantization noise ratio (SQNR). The procedure was practically realized by setting an ADC sampling frequency of 25.6 kHz in conjunction with an internal DMA data management, configured to move 12-bit conversion from the ADC to a circular buffer in the memory. Finally, a digital low-pass multistage decimation FIR filter was developed to generate, at the desired sampling frequency (i.e. 100 Hz), the final stream of three-axes 16-bit acceleration data. According to the capacity of the transmission channel at the above-mentioned LSN sampling frequency for all the three axes, a maximum number of 19 sensors can be connected to each CAN port provided by the gateway. In terms of power consumption, when powered at 5 V in normal operating mode, the current drawn by each node and the gateway device amounts to 32.5 mA and 340 mA respectively.

On the other hand, the sensor network design depends on three major factors: energy efficiency, computational complexity and structural properties. From an electronic point of view, two quantities mainly contribute to the total energy budget, namely the power adsorbed by active nodes for sampling and transmitting data and the gateway communication costs. The computational cost is a function of the total volume of samples to be collected within a specific time-frame (which is an application-dependent quantity) and of the cluster size. More specifically, the sensor network can be described through the following set of parameters: the total amount of available devices N_{tot} and the number of clusters N_c . The corresponding cluster size N_s and the overlapping factor N_o need to be optimized taking into account the practical difficulties which can be associated to the installation of sensors, the maximum

admitted distance between the devices and the presence of antinodal points of modal curves. In particular, the lower bound for N_s is given by the number P of modes which are sufficient to characterize the dynamic behaviour of the structure under test [23], i.e. $N_s \geq P$. For the overlapping factor, the cases of $N_o = 0$ and $N_o = 1$ are the ones which correspond to the minimal sensor redundancy and, for this reason, these cases have been evaluated in the results section.

IV. GSP CLUSTER-BASED MODAL ANALYSIS

The cluster-based monitoring process adopted in this work is schematically depicted in Fig. 2. The primary step consists in defining the most suitable cluster topology and consequently gathering vibration signals $a_i(t)$ from the chosen sensing positions (*clustered sampling*) which form the input of the following feature extraction phase. According to the designed divide-and-conquer architecture, this step is sub-divided into two different stages. Firstly, the identification of modal parameters pertaining to each cluster (*local evaluation*) is comprised. To this end, the FDD and SOBI methodologies mentioned in Section III can be applied.

If N_c is again the number of clusters, N_c sets of P natural frequencies ($f_p^{c_i}$) and mode shapes ($\Phi_p^{c_i}$) are obtained in the local evaluation step; then, a merging procedure has to be executed in order to characterize the whole monitored structure (*global evaluation*) in terms of global natural frequencies ($\mathbf{f} = [f_1 \dots f_P]$) and global modal shapes ($\Phi = [\Phi_1 \dots \Phi_P]$).

Two different procedures are performed in parallel to compute \mathbf{f} and Φ :

- the computation of the cumulative P -tuple of natural frequencies is simply performed by averaging cluster-related frequency values around each p -th modal component.
- the estimation of Φ is performed by concatenating the mode shape portions extracted within adjacent clusters and by properly setting a scaling factor $\alpha_p^{c_i}$ for each cluster c_i at each mode p . i.e. $\tilde{\Phi}_p = [\alpha_p^{c_1} \Phi_p^{c_1}, \dots, \alpha_p^{c_{N_c}} \Phi_p^{c_{N_c}}]$

A novel, GSP-based algorithm was purposely designed to extract the scaling factors for mode shape concatenation. Indeed, the analysis of signals defined on graphs has been gaining increasing attention due to its capability of modeling inherent patterns coded in the acquired data as similarities between adjacent vertices [39], [40].

A *graph* is a mathematical entity described by a set of vertices connected by edges, whose algebraic representation is expressed through the *Adjacency* and *Degree* matrices [39]. The weighted Adjacency matrix \mathbf{W} expresses the vertex connectivity between two generic nodes n and m by means of a correspondent edge weight w_{nm} . Conversely, each entry of the Degree matrix \mathbf{D} is given by the sum of all the weights incident on a specific vertex.

In the presented approach, the topology of the MEMS sensor network is used to define a graph in which modal shape values corresponding to the different sensor node locations are mapped as graph signals associated to graph vertices and edge weights are defined as the inverse of the sensor nodes' spatial distances.

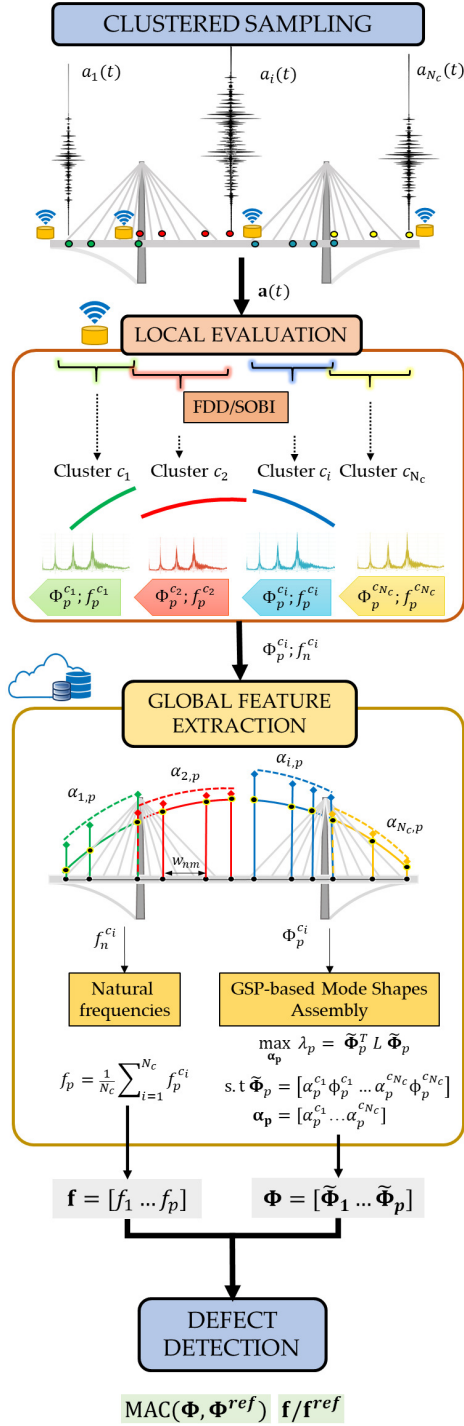

Fig. 2. Schematic representation of the proposed cluster-based and GSP-driven monitoring architecture for vibration analysis.

The proposed modal-to-graph mapping is inspired by the idea to move the smooth modal pattern of modal shapes into the smoothness assumption (i.e. smooth changes between connected vertices) [41] inherent in graph signals. This similarity led to the formalization of the modal shape smoothness λ_p defined as

$$\lambda_p = \frac{1}{2} \sum_{n=1}^{N_{tot}} \sum_{m=1}^{N_{tot}} w_{nm} (\tilde{\Phi}_p(n) - \tilde{\Phi}_p(m))^2 = \tilde{\Phi}_p^T \mathbf{L} \tilde{\Phi}_p \quad (1)$$

where $\tilde{\Phi}_p$ is the p -th modal shape, and $\mathbf{L} = \mathbf{D} - \mathbf{W}$ is the so-called graph Laplacian operator.

Indeed, considering the quasi-sinusoidal dynamic regime typical of vibrating structures, modal curves are supposed to be smooth. However, when modal shapes are assembled from the pure concatenation of the values collected from different clusters (i.e. when the scaling factors are all equal to 1), discontinuities or abrupt jumps may result. In order to compensate these discontinuities and to maximize the mode shape smoothness, an algorithm to tune the scaling factors $\alpha_p^{c_i}$ for every raw modal frame $\tilde{\Phi}_p^{c_i}$ was purposely conceived.

Given a generic p modal shape, such an algorithm involves the following steps:

- 1) During the initialization phase, scaling factors $\alpha_p^{(0)} = [\alpha_p^{c_1}, \dots, \alpha_p^{c_{N_c}}]$ are set to 1.
- 2) Then, modal shapes are assembled and the smoothness function λ_p is computed according to (1).
- 3) Hence, a prediction phase updates the scaling coefficients: the values $\alpha_p^{(k)}$ at iteration k are computed as $\alpha_p^{(k)} = \alpha_p^{(k-1)} - r_p^{(k)} \nabla \lambda_p(\alpha_p^{(k-1)})$, in which $r_p^{(k)} = r_p^{(k-1)} \left(1 + \frac{\lambda_p^k - \lambda_p^{k-1}}{\max\{\lambda_p^k, \lambda_p^{k-1}\}} \right)$ and $\nabla \lambda_p(\cdot)$ are the updating ratio and the smoothness gradient, respectively.
- 4) Steps 2) and 3) are repeated until the smoothness variation between subsequent iterations is smaller than a predefined tolerance ϵ . Apart from the setting of ϵ , the process is therefore fully automated.

The same procedure is executed for every modal shape to be reconstructed. Thus, the matrix of assembled modal shapes $\Phi = [\tilde{\Phi}_1 \dots \tilde{\Phi}_p]$ represents the final output provided by the GSP-based algorithm.

After the global parameters are computed, the presence of damage can be assessed (*damage detection* phase) by comparing the extracted modal parameters with reference values, which can be derived either from the structural response in healthy (baseline) conditions [42] or as a result of numerical simulations for the designed (undamaged) structure. In particular, when the difference between \mathbf{f}^{ref} and \mathbf{f} (i.e. the vectors of resonant frequencies estimated in pristine and current in-operation conditions, respectively) is more than 5%, this is considered as a remarkable deviation in the expected modes of vibration and a possible indication that the investigated structure is damaged [43]. However, such information alone is usually considered to be insufficient, since environmental and operational conditions may generate strong variations too. For this reason, a more accurate assessment of the structural integrity is achieved when the analysis of frequency deviations is complemented with damage detection metrics based on modal shapes.

In particular, the consistency between experimental and baseline modal shapes is evaluated via the Modal Assurance Criterion (MAC) [44]. If variations in environmental conditions and/or structural defects are absent, the MAC factor

returns a value of 100%; therefore, mode shape-driven damage identification strategies track reductions in modal fitting. More precisely, when MAC falls below 90%, the structural integrity may be significantly compromised.

V. EXPERIMENTAL RESULTS

The performance of the developed GSP cluster-based monitoring system was evaluated on a $2142 \text{ mm} \times 10 \text{ mm} \times 60 \text{ mm}$ pinned-pinned steel beam, with $L = 2052 \text{ mm}$ being the effective distance between the supports. Such a setup represents a widely adopted vibration analysis test-bed, because it enables for the use of simple numerical model to predict frequencies and associated mode shapes in nominal dynamic regime. At the same time, numerical models can be easily developed for this structure also in damaged conditions, allowing for the computation of such quantities which are useful for validation purposes. Moreover, regardless of its structural simplicity, the dynamics of a simply supported beam can also be representative of that exhibited by many larger structures, including precast concrete beams and small bridges [23].

The sampling frequency $f_s = 100 \text{ Hz}$, which imposed a Nyquist bandwidth of 50 Hz , was sufficient to retain the first three modes; accordingly, the parameter P was set equal to 3. Assuming the nominal mechanical properties already described in [37], the first three flexural frequencies of vibrations, $f_1 = 5.32 \text{ Hz}$, $f_2 = 21.32 \text{ Hz}$, $f_3 = 47.92 \text{ Hz}$, and the first three mode shapes (Φ_1 , Φ_2 , Φ_3) were analytically predicted by using closed form formulae. Experimentally, the structure was excited with impact hammer and accelerations were acquired for 100s allowing the beam to oscillate under free vibration.

Afterwards, faulty conditions were mimicked by hanging a dead mass on the beam at different positions, thus simulating the formation of localized damages. Changes in the dynamic response of the structure were consequently induced, primarily due to the non symmetric mass distribution. This extra weight, in fact, causes variations in mode shapes which scatter across the mass placement. Correspondingly, spectral shifts with respect to mass-free frequencies of vibration occur, proportionally to the induced perturbation.

The effects of the mass position x_a and the mass values m_a were evaluated. In detail, three different positions $x_{a,1} = 200 \text{ mm}$, $x_{a,2} = 400 \text{ mm}$ and $x_{a,3} = 600 \text{ mm}$ were considered. Beside, the following mass values were hanged step by step at location $x_{a,2}$: $m_{a,1} = 1.078 \text{ kg}$, $m_{a,2} = 1.847 \text{ kg}$, $m_{a,3} = 2.591 \text{ kg}$. The deviations induced in natural frequencies and mode shapes were a priori estimated through an in-house developed finite element numerical model, taking into account the effect of the added mass on the stiffness and rigidity of the beam. To this end, the numerical model discussed in [37] was revised including the impingement of the electronic equipment (e.g., sensor mass). Accordingly, experimental modal parameters were extracted and compared to simulation results in order to validate the suitability of the proposed scheme under potential defective conditions.

TABLE I
RELATIVE ERROR IN FDD-DRIVEN NATURAL FREQUENCIES ESTIMATION BETWEEN EXPERIMENTAL DATA AND THEORETICAL PREDICTION FOR DIFFERENT SCENARIOS.

| Mode | Fixed mass $m_{a,1}$ | | | Fixed position $x_{a,1}$ | |
|-------|----------------------|------------------|------------------|--------------------------|------------------|
| | $x_{a,1}$ [%] | $x_{a,2}$ [%] | $x_{a,3}$ [%] | $m_{a,2}$ [%] | $m_{a,3}$ [%] |
| f_1 | 2.003 | 1.525 | 1.235 | 1.109 | 1.186 |
| f_2 | 0.957 | 0.687 | 0.938 | 0.006 | 1.436 |
| f_3 | 0.710 | 1.279 | 1.436 | 1.222 | 1.348 |

A. Clustering scheme

In the considered experiments, a sensor network constituted by two clusters (specifically labeled by red and blue markers) was designed, whose grouping schemes are depicted in Fig. 3. In particular, case O_v sketches a network with overlapped clusters, each consisting of 5 sensor nodes ($A_{1,\dots,5}$ and $A_{5,\dots,9}$, respectively) installed at nine different positions uniformly distributed along the entire length of the beam. In this case, modal parameters were extracted with the PoSER procedure, and accelerometer A_5 was used as the reference point for re-scaling. Cases A-D are conversely referred to non-overlapped clusters with different (and irregular) sensor spacing to examine the influence of sensor placement in modal parameter estimation. In particular, case D is a particularly unfavourable arrangement with minimal clusters' size and significant inter-cluster distance, while case A is the most redundant and denser configuration.

Resilience against thermal fluctuations, excitation uncertainty and measurement asynchronicity were additionally investigated. For this purpose, the experiments were designed to acquire acceleration signals separately with the two clusters in two different moments: sensors at positions $A_{1,\dots,5}$ (cluster c_1) were activated at operating conditions characterized by high temperatures (29°C) and low input force, whereas sensors $A_{5,\dots,9}$ (cluster c_2) worked at relatively low temperatures (17°C) and stronger excitation energy.

B. Feature extraction

A frequency-based assessment was firstly conducted. The spectral profiles depicted in Fig. 4 were generated with the FDD algorithm and demonstrate the capability of the system to identify variations in natural frequencies due to the presence of added masses. In fact, the results reveal good vertical alignment between experimental spectral peaks and numerically predicted modal components. The relative differences with respect to theoretical simulations under the same operating conditions are reported in Table I. For all the tested configurations, an average discrepancy of 1.183% is observed considering all the three modes of interest.

The analysis was then extended to the reconstruction of mode shapes. The signal processing techniques (FDD, SOBI) mentioned in Section II were applied to extract the modal parameters related to each cluster. The modal shapes were thereafter concatenated according to the algorithmic procedures detailed in Section IV. For each inspected configuration,

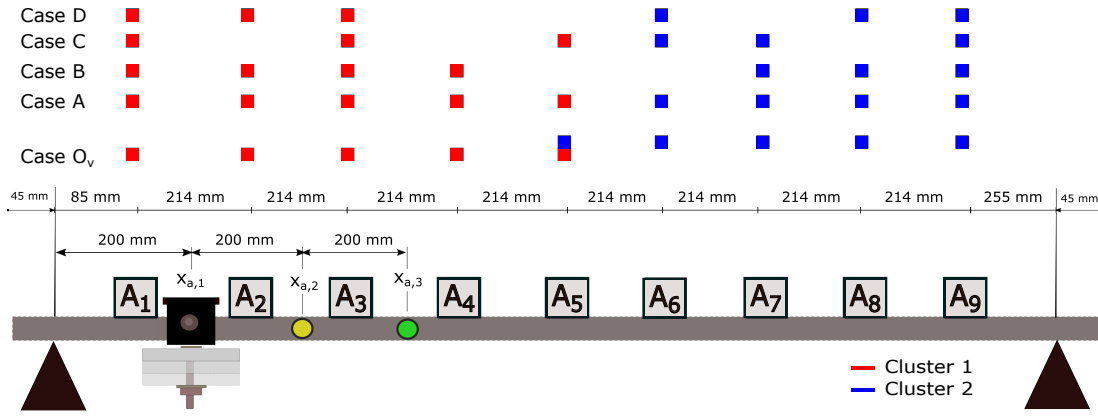

Fig. 3. Experimental setup with two clusters of sensors (red and blue-labelled chains): overlapping networks in correspondence of node A_5 (case O_v) and non-overlapping (case A, B, C, D) configurations. Unhealthy conditions were induced by means of a concentrated roving mass laterally hanged at positions $x_{a,1}$, $x_{a,2}$, $x_{a,3}$.

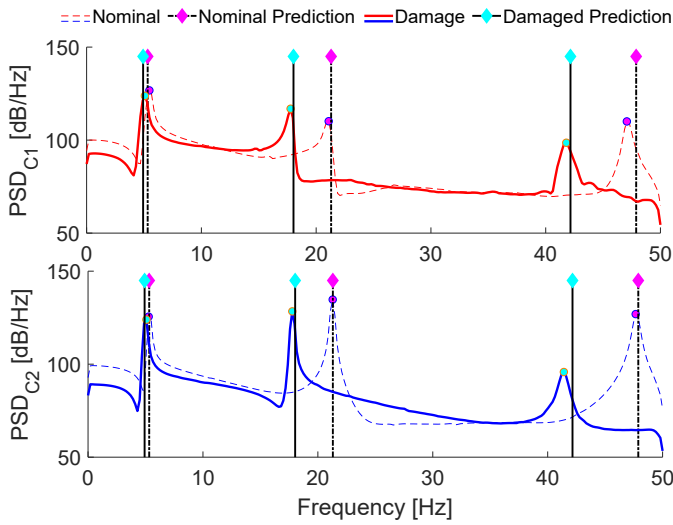

Fig. 4. Spectra of signals acquired with sensor cluster c_1 (top graph) and c_2 (bottom graph). The damaged configuration (continuous line) corresponding to operating conditions perturbed with additive mass $m_a = 2.591$ kg at $x_a = 400$ mm is superimposed to the nominal case (dotted line). Numerical predictions in both situations are also included.

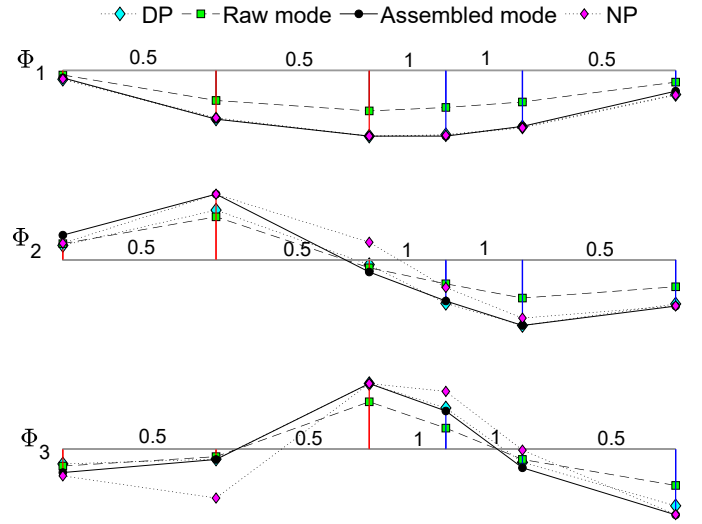

Fig. 5. Assembled mode shapes for the altered beam with additive mass $m_a = 2.591$ kg at $x_{a,2}$ under non-overlapped configuration of case C. Raw modal coordinates are extracted by means of the FDD reconstruction method. Theoretical predictions in nominal (NP) and damaged status (DP) are also provided.

MAC percentages computed between numerically expected and experimentally estimated mode shapes were employed to quantify the correspondent degree of structural coherence.

1) *Overlapped configuration*: The performance of the PoSER approach [33] in case of overlapped clusters is reported in Table III (case O_v). Noticeably, an almost perfect superimposition to theoretical predictions is achieved in modal envelope extraction, attested by modal correlation indexes which are always above 98% even in the worst case, associated with strongly perturbed tests performed with the heaviest mass. It is worth highlighting that even the SOBI-based modal shape estimation fits the model nearly perfectly in all the scenarios, showing its robustness for modal analysis purposes in spite of its fully unsupervised approach.

2) *Non-overlapped configurations*: The performances of the non-overlapped network configurations (case A, B, C and D) were tested under the same damaged conditions. In

these cases, modal coordinates were extracted by means of the already discussed graph smoothness maximization method presented in Section IV. A tolerance error $\epsilon = 10^{-4}$, an initial updating ratio $r^{(0)} = 0.5$ and a starting smoothness gradient $\nabla \lambda_p = 1$ were empirically estimated to achieve the best trade-off between the resulting modal accuracy and the algorithmic convergence velocity.

The potential of GSP tools elicits from their intrinsic capability to derive the proper graph topology compliant to the best graph signal smoothness in all the considered sensor arrangements. An example of graph-combined mode shapes (black dots) is drawn in Fig. 5, where raw modal coordinates (black stars) are extracted through the FDD technique for case C. The numerical values drawn above arches connecting adjacent vertices represent the corresponding edge weights. Going deeper into the analysis, an evident greater level of superimposition is achieved after GSP operators are applied

TABLE II
MAC VALUES COMPARING NUMERICAL PREDICTION AND ASSEMBLED MODE SHAPES IN IN PRESENCE OF ALTERED CONDITIONS WITH OVERLAPPED CLUSTERS (CASE O_v-POSER APPROACH) AND SPATIALLY INDEPENDENT CLUSTERS (CASE A, B, C, AND D-GSP APPROACH).

| Case | Mode | Fixed mass $m_{a,1}$ | | | Fixed position $x_{a,2}$ | | |
|----------------|------|----------------------|-----------|-----------|--------------------------|-----------|-------|
| | | $x_{a,1}$ | $x_{a,2}$ | $x_{a,3}$ | $m_{a,2}$ | $m_{a,3}$ | |
| O _v | FDD | f_1 | 99.93 | 99.92 | 99.82 | 99.94 | 99.94 |
| | | f_2 | 99.15 | 99.25 | 99.46 | 99.13 | 98.21 |
| | | f_3 | 99.49 | 99.72 | 98.44 | 99.27 | 99.11 |
| | SOBI | f_1 | 99.96 | 99.93 | 99.91 | 99.95 | 99.95 |
| | | f_2 | 99.25 | 99.16 | 99.21 | 94.15 | 98.85 |
| | | f_3 | 99.75 | 99.41 | 98.84 | 99.00 | 97.40 |
| A | FDD | f_1 | 99.83 | 99.63 | 99.58 | 99.54 | 99.58 |
| | | f_2 | 99.17 | 97.31 | 96.62 | 97.01 | 98.55 |
| | | f_3 | 98.56 | 98.54 | 99.16 | 97.20 | 97.49 |
| | SOBI | f_1 | 99.95 | 99.92 | 99.89 | 99.85 | 99.90 |
| | | f_2 | 99.18 | 98.18 | 97.31 | 97.83 | 96.87 |
| | | f_3 | 98.86 | 98.66 | 98.89 | 97.21 | 96.04 |
| B | FDD | f_1 | 99.90 | 99.82 | 99.66 | 99.54 | 99.81 |
| | | f_2 | 99.61 | 99.41 | 98.13 | 98.53 | 97.36 |
| | | f_3 | 99.13 | 98.73 | 98.27 | 96.71 | 97.00 |
| | SOBI | f_1 | 99.92 | 99.88 | 99.85 | 99.83 | 99.88 |
| | | f_2 | 99.78 | 99.43 | 98.80 | 98.64 | 97.46 |
| | | f_3 | 99.57 | 98.74 | 98.68 | 97.09 | 96.25 |
| C | FDD | f_1 | 99.95 | 99.92 | 99.76 | 95.77 | 95.84 |
| | | f_2 | 99.33 | 99.49 | 98.29 | 98.48 | 97.40 |
| | | f_3 | 99.30 | 99.51 | 95.42 | 99.11 | 99.39 |
| | SOBI | f_1 | 99.97 | 99.95 | 99.92 | 96.07 | 99.97 |
| | | f_2 | 99.40 | 99.43 | 98.48 | 98.64 | 97.35 |
| | | f_3 | 98.65 | 99.44 | 95.61 | 98.69 | 93.06 |
| D | FDD | f_1 | 97.13 | 97.54 | 96.79 | 96.64 | 97.72 |
| | | f_2 | 99.15 | 99.06 | 97.68 | 98.18 | 96.90 |
| | | f_3 | 99.33 | 98.96 | 98.74 | 96.38 | 94.87 |
| | SOBI | f_1 | 97.00 | 97.39 | 97.35 | 97.33 | 97.63 |
| | | f_2 | 99.11 | 99.18 | 98.48 | 98.29 | 97.02 |
| | | f_3 | 99.29 | 98.58 | 98.72 | 95.86 | 90.13 |

for the reconstruction of the complete modal curves. In order to perform a quantitative evaluation, cases A-D in Table II synthetically report computed MAC values between numerical expectations and graph-assembled modal coordinates, the highly accurate fitting among them being proved by modal correlation indexes averagely above 95%. Another aspect should further be underlined: despite isolated cases related to the reconstruction of the third vibration mode subjected to the heaviest added masses, the effectiveness of the proposed GSP algorithm attains very high scores both starting with supervised (FDD) and unsupervised (SOBI) modal inspection methods. In particular, the maximum deviation between these two categories amounts to less than 7 point percentages, without exceeding the tolerance interval of 90% considered as a damage threshold. Furthermore, conducting a comparative analysis with respect to already existing methodologies, albeit a slight decrease in modal fitting occurs among traditional overlapped solutions and unconventional disjoint configura-

tions, the coherence of the GSP method averagely worsens for less than 1.1% compared to covariance-based alternatives. As a matter of fact, it is reasonable that the worst performance is associated to sparser sampling configurations, longer intra-cluster distances, and minimal cluster sizes (i.e. $N_s = P$). Nevertheless, the proposed processing achieved a maximum deviation of approximately 7% (related to the reconstruction of the third mode for sensing case D, again in the tolerance range), hence showing its suitability for damage monitoring tasks.

VI. CONCLUSION

In this paper, a novel cluster-based vibration monitoring system, suitable for structural integrity assessment, is described. The system stands out for its modularity, level of integration, and versatility, derived by a novel divide-and-conquer strategy for modal analysis. In particular, a dedicated graph signal processing method was proposed for non-overlapped sensor clusters, hence easing the sensor deployment in complex structures and overcoming electrical and geometrical constraints.

The accuracy of the monitoring system was evaluated through an experimental validation, designed to take into account non-stationary phenomena, such as the effect of thermal excursions, blind excitation, and lack of synchronization between clusters. In addition, the nominal properties of the structure were altered by simulating the presence of a defect through the insertion of concentrated masses. The properties of the developed hardware and software solutions proved to output reliable results. In fact, in all the considered experimental conditions, the spectral and modal signatures estimated by the monitoring system showed a significant concordance to theoretical predictions. For this reason, the presented mode shape assembly procedure appears to be a promising strategy to overtake the current limitations of state-of-the-art overlapped clustered solutions. Further developments will include the application of the proposed network on mesoscale structures.

ACKNOWLEDGMENT

This work has been funded by INAIL within the BRIC/2018, ID = 11 framework, project MAC4PRO and the European Union's Horizon 2020 research and innovation programme under Arrowhead Tools project, grant agreement No 826452.

REFERENCES

- [1] C. A. Tokognon, B. Gao, G. Y. Tian, and Y. Yan, "Structural health monitoring framework based on internet of things: A survey," *IEEE Internet of Things Journal*, vol. 4, no. 3, pp. 619–635, 2017.
- [2] P. Lall, R. Lowe, and K. Goebel, "Prognostics health management of electronic systems under mechanical shock and vibration using kalman filter models and metrics," *IEEE Transactions on Industrial Electronics*, vol. 59, no. 11, pp. 4301–4314, 2012.
- [3] M. Magno, D. Boyle, D. Brunelli, B. O'Flynn, E. Popovici, and L. Benini, "Extended wireless monitoring through intelligent hybrid energy supply," *IEEE Transactions on Industrial Electronics*, vol. 61, no. 4, pp. 1871–1881, 2014.
- [4] A. Sabato, C. Niezrecki, and G. Fortino, "Wireless mems-based accelerometer sensor boards for structural vibration monitoring: a review," *IEEE Sensors Journal*, vol. 17, no. 2, pp. 226–235, 2017.

- [5] N. Testoni, C. Aguzzi, V. Arditì, F. Zonzini, L. De Marchi, A. Marzani, and T. S. Cinotti, "A sensor network with embedded data processing and data-to-cloud capabilities for vibration-based real-time shm," *Journal of Sensors*, vol. 2018, 2018.
- [6] P.-Y. Chen, S. Yang, and J. A. McCann, "Distributed real-time anomaly detection in networked industrial sensing systems," *IEEE Transactions on Industrial Electronics*, vol. 62, no. 6, pp. 3832–3842, 2015.
- [7] Y. Yu, J. Ou, J. Zhang, C. Zhang, and L. Li, "Development of wireless mems inclination sensor system for swing monitoring of large-scale hook structures," *IEEE Transactions on Industrial Electronics*, vol. 56, no. 4, pp. 1072–1078, 2009.
- [8] C. Rainieri and G. Fabbrocino, "Operational modal analysis of civil engineering structures," *Springer, New York*, vol. 142, p. 143, 2014.
- [9] R. Duan and F. Wang, "Fault diagnosis of on-load tap-changer in converter transformer based on time–frequency vibration analysis," *IEEE Transactions on Industrial Electronics*, vol. 63, no. 6, pp. 3815–3823, 2016.
- [10] T. Nagayama and B. F. Spencer Jr, "Structural health monitoring using smart sensors," Newmark Structural Engineering Laboratory. University of Illinois at Urbana . . . , Tech. Rep., 2007.
- [11] V. Krishnamurthy, K. Fowler, and E. Sazonov, "The effect of time synchronization of wireless sensors on the modal analysis of structures," *Smart Materials and Structures*, vol. 17, no. 5, p. 055018, 2008.
- [12] J. J. Moughty and J. R. Casas, "A state of the art review of modal-based damage detection in bridges: development, challenges, and solutions," *Applied Sciences*, vol. 7, no. 5, p. 510, 2017.
- [13] A. Ortega, P. Frossard, J. Kovačević, J. M. Moura, and P. Vanderghyest, "Graph signal processing: Overview, challenges, and applications," *Proceedings of the IEEE*, vol. 106, no. 5, pp. 808–828, 2018.
- [14] J.-J. Sinou, "A review of damage detection and health monitoring of mechanical systems from changes in the measurement of linear and non-linear vibrations," 2009.
- [15] M. Dahak, N. Touat, and M. Kharoubi, "Damage detection in beam through change in measured frequency and undamaged curvature mode shape," *Inverse Problems in Science and Engineering*, vol. 27, no. 1, pp. 89–114, 2019.
- [16] R. Brincker and C. Ventura, *Introduction to operational modal analysis*. John Wiley & Sons, 2015.
- [17] F. Poncelet, G. Kerschen, J.-C. Golinval, and D. Verhelst, "Output-only modal analysis using blind source separation techniques," *Mechanical systems and signal processing*, vol. 21, no. 6, pp. 2335–2358, 2007.
- [18] X. Liu, J. Cao, W.-Z. Song, P. Guo, and Z. He, "Distributed sensing for high-quality structural health monitoring using wsn," *IEEE Transactions on Parallel and Distributed Systems*, vol. 26, no. 3, pp. 738–747, 2015.
- [19] Y.-A. Chapuis, L. Zhou, Y. Fukuta, Y. Mita, and H. Fujita, "Fpga-based decentralized control of arrayed mems for microrobotic application," *IEEE Transactions on Industrial Electronics*, vol. 54, no. 4, pp. 1926–1936, 2007.
- [20] B. Spencer, T. Nagayama, and J. A. Rice, "Decentralized structural health monitoring using smart sensors," in *Sensors and Smart Structures Technologies for Civil, Mechanical, and Aerospace Systems 2008*, vol. 6932. International Society for Optics and Photonics, 2008, p. 693202.
- [21] F. Hu and Q. Hao, *Intelligent sensor networks: the integration of sensor networks, signal processing and machine learning*. CRC Press, 2012.
- [22] A. Diez, N. L. D. Khoa, M. M. Alamdari, Y. Wang, F. Chen, and P. Runcie, "A clustering approach for structural health monitoring on bridges," *Journal of Civil Structural Health Monitoring*, vol. 6, no. 3, pp. 429–445, 2016.
- [23] K. Fang, C. Liu, and J. Teng, "Cluster-based optimal wireless sensor deployment for structural health monitoring," *Structural Health Monitoring*, vol. 17, no. 2, pp. 266–278, 2018.
- [24] X. Liu, J. Cao, S. Lai, C. Yang, H. Wu, and Y. L. Xu, "Energy efficient clustering for wsn-based structural health monitoring," in *INFOCOM, 2011 Proceedings IEEE*. IEEE, 2011, pp. 2768–2776.
- [25] M. Abdulkarem, K. Samsudin, F. Z. Rokhani, and M. F. A. Rasid, "Wireless sensor network for structural health monitoring: A contemporary review of technologies, challenges, and future direction," *Structural Health Monitoring*, p. 1475921719854528, 2019.
- [26] P. K. Patil and S. Patil, "Review on structural health monitoring system using wsn for bridges," in *2017 International conference of Electronics, Communication and Aerospace Technology (ICECA)*, vol. 1. IEEE, 2017, pp. 628–631.
- [27] A. B. Noel, A. Abdaoui, T. Elfouly, M. H. Ahmed, A. Badawy, and M. S. Shehata, "Structural health monitoring using wireless sensor networks: A comprehensive survey," *IEEE Communications Surveys & Tutorials*, vol. 19, no. 3, pp. 1403–1423, 2017.
- [28] G. Hackmann, W. Guo, G. Yan, Z. Sun, C. Lu, and S. Dyke, "Cyber-physical codesign of distributed structural health monitoring with wireless sensor networks," *IEEE Transactions on Parallel and Distributed Systems*, vol. 25, no. 1, pp. 63–72, 2014.
- [29] S.-H. Sim, J. F. Carbonell-Márquez, B. Spencer Jr, and H. Jo, "Decentralized random decrement technique for efficient data aggregation and system identification in wireless smart sensor networks," *Probabilistic Engineering Mechanics*, vol. 26, no. 1, pp. 81–91, 2011.
- [30] S. Yuan, Y. Ren, L. Qiu, and H. Mei, "A multi-response-based wireless impact monitoring network for aircraft composite structures," *IEEE Transactions on Industrial Electronics*, vol. 63, no. 12, pp. 7712–7722, 2016.
- [31] A. T. Zimmerman, M. Shiraishi, R. A. Swartz, and J. P. Lynch, "Automated modal parameter estimation by parallel processing within wireless monitoring systems," *Journal of Infrastructure Systems*, vol. 14, no. 1, pp. 102–113, 2008.
- [32] I. L. Dos Santos, L. Pirmez, É. T. Lemos, F. C. Delicato, L. A. V. Pinto, J. N. de Souza, and A. Y. Zomaya, "A localized algorithm for structural health monitoring using wireless sensor networks," *Information Fusion*, vol. 15, pp. 114–129, 2014.
- [33] M. Döhler, E. Reynders, F. Magalhaes, L. Mevel, G. De Roeck, and A. Cunha, "Pre- and post-identification merging for multi-setup oma with covariance-driven ssi," in *Dynamics of Bridges, Volume 5*. Springer, 2011, pp. 57–70.
- [34] S.-K. Au, "Assembling mode shapes by least squares," *Mechanical Systems and Signal Processing*, vol. 25, no. 1, pp. 163–179, 2011.
- [35] Ç. Hızal, G. Turan, E. Aktaş, and H. Ceylan, "A mode shape assembly algorithm by using two stage bayesian fast fourier transform approach," *Mechanical Systems and Signal Processing*, vol. 134, p. 106328, 2019.
- [36] M. Ceriotti, L. Mottola, G. P. Picco, A. L. Murphy, S. Guna, M. Corra, M. Pozzi, D. Zonta, and P. Zanon, "Monitoring heritage buildings with wireless sensor networks: The torre aquila deployment," in *Proceedings of the 2009 international conference on information processing in sensor networks*. IEEE Computer Society, 2009, pp. 277–288.
- [37] A. Girolami, F. Zonzini, L. De Marchi, D. Brunelli, and L. Benini, "Modal analysis of structures with low-cost embedded systems," in *Circuits and Systems (ISCAS), 2018 IEEE International Symposium on*. IEEE, 2018, pp. 1–4.
- [38] A. Girolami, D. Brunelli, and L. Benini, "Low-cost and distributed health monitoring system for critical buildings," in *2017 IEEE Workshop on Environmental, Energy, and Structural Monitoring Systems (EESMS)*, July 2017, pp. 1–6.
- [39] D. I. Shuman, S. K. Narang, P. Frossard, A. Ortega, and P. Vanderghyest, "The emerging field of signal processing on graphs: Extending high-dimensional data analysis to networks and other irregular domains," *arXiv preprint arXiv:1211.0053*, 2012.
- [40] I. Jabłoński, "Graph signal processing in applications to sensor networks, smart grids, and smart cities," *IEEE Sensors Journal*, vol. 17, no. 23, pp. 7659–7666, 2017.
- [41] M. Daković, L. Stanković, and E. Sejdić, "Local smoothness of graph signals," *Mathematical Problems in Engineering*, vol. 2019, 2019.
- [42] W. Contreras and S. Ziaavras, "Efficient infrastructure damage detection and localization using wireless sensor networks, with cluster generation for monitoring damage progression," in *Ubiquitous Computing, Electronics and Mobile Communication Conference (UEMCON), 2017 IEEE 8th Annual*. IEEE, 2017, pp. 173–178.
- [43] Z. Hong-Ping, H. Bo, and C. Xiao-qiang, "Detection of structural damage through changes in frequency," *Wuhan University Journal of Natural Sciences*, vol. 10, no. 6, pp. 1069–1073, 2005.
- [44] M. Pastor, M. Binda, and T. Harčarik, "Modal assurance criterion," *Procedia Engineering*, vol. 48, pp. 543–548, 2012.

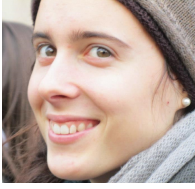

Federica Zonzini (S'19) received the B.S. and the M.S. degree in Electronics Engineering at the University of Bologna in 2016 and 2018, respectively. She is currently pursuing the Ph.D in Engineering and Information Technology for Structural and Environmental Monitoring and Risk Management (EIT4SEMM) with the University of Bologna, Italy. Her main research interests include advanced signal processing techniques for structural health monitoring application, encompassing graph signal processing,

data-fusion, compressive sensing and damage assessment.



Alberto Girolami received the B.S. and the M.S. degree in Electronics Engineering at the University of Bologna, Italy, in 2011 and 2015, respectively. His main research interests include the optimization of low-cost, low-power and wireless embedded system with applications in structural health monitoring.



Luca De Marchi (S'10, M'12) is associate professor in Electronics in the Department of Electrical, Electronic, and Information Engineering of the University of Bologna, Italy. He has published more than 140 papers in international journals or in proceedings of international conferences, and holds two patents. His current research interests are in multiresolution and adaptive signal processing, with a particular emphasis on structural health monitoring applications.



Alessandro Marzani is an Associate Professor of Structural Mechanics and currently the Coordinator of the PhD Program in "Engineering and Information Technology for Structural and Environmental Monitoring and Risk Management - EIT4SEMM". He received a M.Sc. in Structural Engineering from the University of California San Diego, a M.Sc. (Laurea) in Civil Engineering from the University of Bologna, and the Ph.D. in Engineering of Materials and Structures from the University of Calabria, Italy in

2005. Dr. Marzani research interests include non-destructive evaluation techniques of materials and structures, structural monitoring, linear and non-linear ultrasonic guided wave propagation, structural optimization and identification strategies, structured materials for wave propagation control (metamaterials). He is a LEVEL 3 for NDT testing based on guided waves (UNI EN 473 e ISO 9712), holds three patents, and he actively cooperates with public authorities on national guidelines and standardization issues.



Davide Brunelli (M'10, SM'16) received his M.S. (cum laude) and Ph.D. degrees in electrical engineering from the University of Bologna, Italy, in 2002 and 2007, respectively. He was a visiting researcher with ETH Zürich, Switzerland, where he was involved in methodologies for energy-harvesting-aware embedded design. He is currently an associate professor at the University of Trento, Italy. He is a member of several Technical Program Committees of conferences in the field of Internet of Things (IoT) and energy management.

He has published more than 200 papers in international journals or proceedings of international conferences and holds a patent. He was leading industrial cooperation activities from 2007, with Telecom Italia, ENI, and STMicroelectronics. His current research interests include smart grids and the development of new techniques of energy scavenging for the Internet of Things and embedded systems, the optimization of low-power and low-cost consumer electronics, and the interaction and design issues in embedded personal and wearable devices.