



ALMA MATER STUDIORUM
UNIVERSITÀ DI BOLOGNA

ARCHIVIO ISTITUZIONALE
DELLA RICERCA

Alma Mater Studiorum Università di Bologna Archivio istituzionale della ricerca

Fatigue life performances of silicone elastomer membranes for dielectric elastomer transducers: Preliminary results

This is the final peer-reviewed author's accepted manuscript (postprint) of the following publication:

Published Version:

Chen Y., Agostini L., Moretti G., Berselli G., Fontana M., Vertechy R. (2019). Fatigue life performances of silicone elastomer membranes for dielectric elastomer transducers: Preliminary results. SPIE [10.1117/12.2515312].

Availability:

This version is available at: <https://hdl.handle.net/11585/710442> since: 2019-12-23

Published:

DOI: <http://doi.org/10.1117/12.2515312>

Terms of use:

Some rights reserved. The terms and conditions for the reuse of this version of the manuscript are specified in the publishing policy. For all terms of use and more information see the publisher's website.

This item was downloaded from IRIS Università di Bologna (<https://cris.unibo.it/>).
When citing, please refer to the published version.

(Article begins on next page)

Fatigue life performances of silicone elastomer membranes for dielectric elastomer transducers: preliminary results

Yi Chen^{*a}, Lorenzo Agostini^b, Giacomo Moretti^b,
Giovanni Berselli^c, Marco Fontana^d, Rocco Vertechy^a

^aUniversity of Bologna, Bologna, Italy

^bScuola Superiore Sant'Anna, Pisa, Italy

^cUniversity of Genova, Genova, Italy

^dUniversity of Trento, Trento, Italy

ABSTRACT

Dielectric Elastomer Transducers (DETs) are a promising technology for the development of actuators, generators and sensors with high performance and low cost. Practical application and economic viability of DETs is strongly affected by their reliability and lifetime, which depend on the maximum strain and electrical loads that are cyclically applied on such devices. To date, only limited information is available on the fatigue life performances of dielectric elastomer materials and of the transducers made thereof.

This paper reports on a first lifetime constant electric-stress test campaign conducted on 38 free-expanding frame-stretched circular DET specimens, made of the silicone elastomer film Elastosil® 2030 250/150 by Wacker with blade-casted carbon-black silicone-elastomer electrodes, that have been subjected to nearly square wave electric field signals with 1 Hz frequency, 50% duty cycle and with amplitudes ranging from 65 MV/m to 80 MV/m.

Keywords: Dielectric Elastomer, Electrical Degradation, Electrical Breakdown, Fatigue Life, Reliability

1. INTRODUCTION

Dielectric Elastomer Transducers (DETs) are electrical condensers with deformation dependent capacitance [1]. They feature a multi-layered architecture, comprising one or more sheets of incompressible Dielectric Elastomer (DE) that are sandwiched between compliant electrodes. Thanks to their ability to reversibly convert mechanical energy into direct current electricity DETs can be exploited to conceive new forms of solid-state electrostatic actuators, generators and sensors [1, 2, 3].

In actuator mode, electrostatic attraction between the oppositely charged electrodes of the DET is used to convert electricity into mechanical energy. In generator mode, mechanical energy is converted into electricity via the variable-capacitance electrostatic generation principle. In sensor mode, capacitance measurement is used to infer DET deformation.

Properties of DETs which make them suited for transduction applications are: low mass density; large deformability; high energy density; moderate or low cost; solid-state monolithic embodiment with no sliding parts; ease of manufacturing, assembling and recycling; good chemical resistance to corrosive environments; silent operation.

Over the years, membranes made of different dielectric elastomer materials demonstrated excellent electromechanical properties for the development of DETs with high power density and suitable energy conversion efficiency [4,5]. As an example, the following experimental performances have been demonstrated in laboratory generator applications: 780 J/kg for a planar circular DET made with an acrylic elastomer (VHB 4905 by 3M) dielectric layer undergoing equi-biaxial expansion [6]; 370 J/kg for an inflating circular diaphragm DET made with a natural rubber (OPPO BAND GREEN 8003) dielectric layer undergoing bubble like deformation [7]; 173 J/kg for a DET with similar geometry and loading of the previous one but made with a silicone elastomer (Elastosil® 2030 by Wacker) dielectric layer [8]. Worth mentioning: the lower energy density values reported for natural rubber and silicone elastomer are not due to limits in the material properties, but only to the shape and loading of the considered inflatable bubble-like specimens that make their deformation

state inhomogeneous and anisotropic. Far higher numbers are expected for natural rubber and silicone elastomer DETs configured so as to have the material working under equi-biaxial deformation states.

Typically, outstanding experimental performances like those reported above can however be sustained for a limited number of cycles only, after which the DET will fail irreversibly. To date, only a few results are available on the long-lifetime performances of dielectric elastomer materials and of the transducers made thereof. In particular: the fatigue resistance of DETs made with acrylic elastomer and styrenic rubber has been studied in [9] and [10], respectively; the high-cycle aging of DETs made of silicone elastomers has been investigated in [11].

In this context, this paper describes the preliminary lifetime results for free-expanding frame-stretched circular DET specimens, made of the commercial silicone elastomer membrane Elastosil® 2030 250/150 by Wacker and with blade-casted carbon-black silicone-elastomer electrodes, subjected to constant electric-stress testing conditions [10]. After a description of specimen preparation as well as of testing set-up and procedures, the paper reports and discusses the obtained experimental results.

2. SPECIMEN PREPARATION

Free-expanding frame-stretched circular DET specimens [10] made of the Wacker Elastosil® 2030 250/150 silicone elastomer film (featuring a thickness of 150 μm in the undeformed state) have been prepared in batches of eight identical units by means of the procedure described in a previous work [8] for the manufacturing of an inflatable circular diaphragm DET generator. A picture of a batch of eight frame-stretched circular specimens right after completion of manufacturing is displayed in Figure 1.a; three batches under preparation are shown in Figure 1.b.

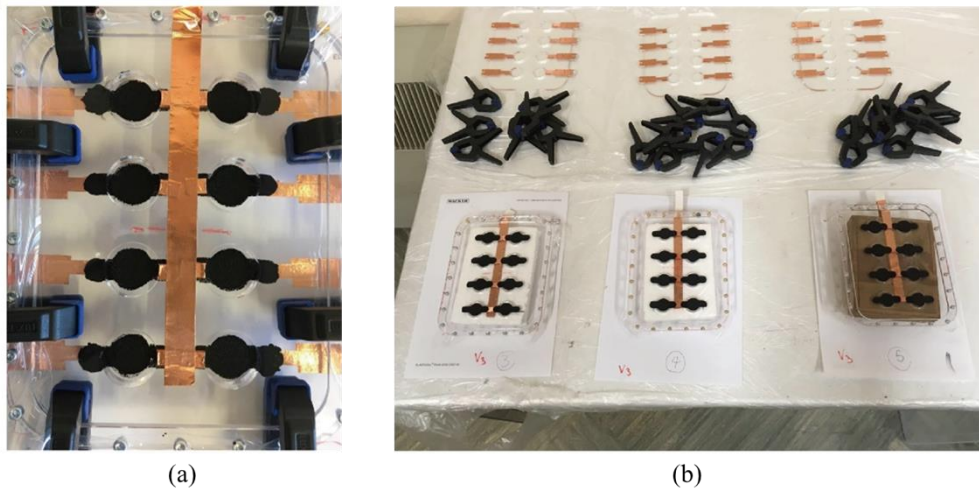

Figure 1. Pictures of a batch of eight free-expanding frame-stretched circular DET specimens made with the Wacker Elastosil® 2030 250/150 silicone elastomer film and blade-casted carbon-black silicone-elastomer electrodes (a) and of three batches of these DET specimens under preparation (b).

For each batch, a holding frame made of laser-cut polycarbonate plastic is used to provide a stiff circular boundary to each of the eight specimens as well as to keep them in a pre-stretched state. For the experiments reported in this work, a pre-stretch ratio of 1.1 is considered. The holding frame consists of a lower and an upper elements, with the silicone elastomer film lying in between. As depicted in Figure 2.a, the lower element is comprised of two parts: an outer rectangular ring with round corners and an inner plate. The outer ring is used to apply the pre-stretch to the silicone elastomer film and to keep it by wrapping the film to M3 screws fastened to the plastic ring. Mild adhesion between silicone elastomer and polycarbonate plastic also helps in preventing the film to slip over the ring. The inner plate features a matrix of 2 x 4 identical holes with 25 mm diameter, each delimiting one of the eight DET specimens. Figure 2.b shows the upper frame

plate, which features a duplication of the holes delimiting the specimen boundary that exactly match those in the bottom inner plate.

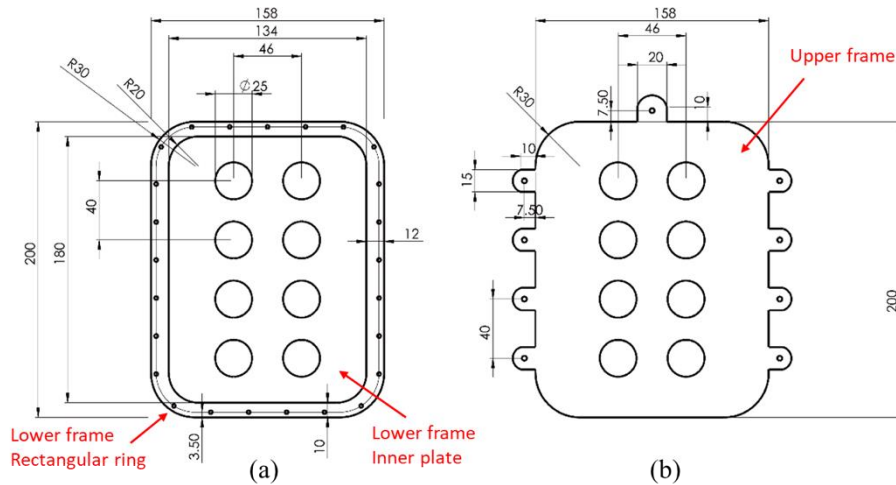

Figure 2. Schematics of the frame plates for free-expanding frame-stretched circular DET specimens with hole diameters equal to 25 mm: (a) lower frames, (b) upper frame [dimensions in millimeters].

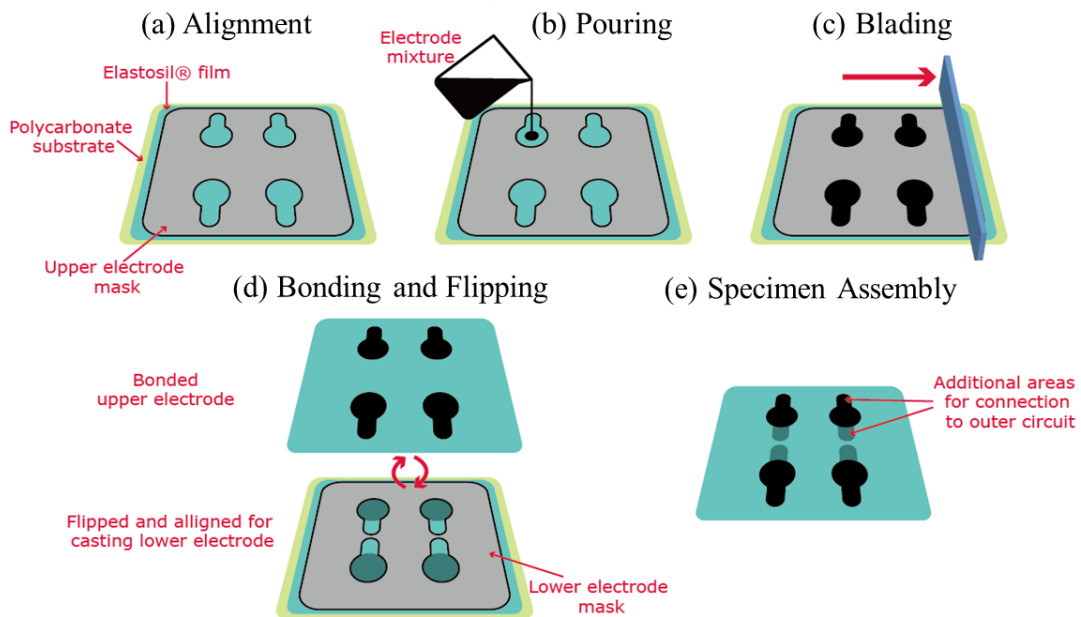

Figure 3. Phases for the realization of silicone based compliant electrodes (only four specimens are shown here for simplicity): (a) align the casting mask on the silicone film lying on a polycarbonate substrate, (b) pure electrode mixture on the mask holes; (c) blade-cast electrode mixture over the masks; (d) remove excess of electrode mixture alongside with the masks, and cure deposited electrode mixture under ambient conditions. Once the curing is finished, the silicone film is flipped over and phases (a)-(c) are repeated for casting the lower electrode pattern; (e) a final assembly of the casted upper and lower electrodes with additional areas for connection to the outer electrical circuit (made with copper strips).

Specimen electrodes are made by a carbon-black silicone-elastomer mixture. Firstly, carbon black powder is ball-milled for 15 minutes dissolved in Isopropyl Alcohol (IPA) with a weight ratio of 1:10 and a total weight of 8.8 g. This allows to finely grind the carbon black in very small particles and makes them well dispersed in the solvent. Second, a two-component silicone rubber ELASTOSIL® RT 625 A/B (with a weight ratio of A:B = 9:1 and total weight of 8 g) and

another portion of IPA (8 g) are poured into the ball-milled mixture, which is then mixed again for another 15 minutes to reach an evenly stirred state that is necessary for proper addition curing of ELASTOSIL® RT 625.

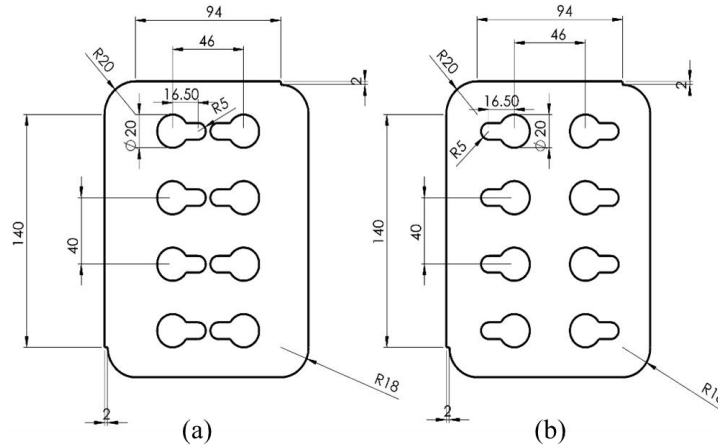

Figure 4. Schematics of the casting masks for free-expanding frame-stretched circular DET specimens with electrode diameters equal to 20 mm: (a) mask for lower electrodes, (b) mask for upper electrodes.

Finally, the resulting mixture is used to cast the electrodes on both sides of the silicone film according to the procedure shown in Figure 3 (and described in more details in [8]) using the casting masks for upper and lower electrodes depicted in Figure 4. Upper electrodes are casted first, followed by drying and cross-linking for 12 hours in ambient air at room temperature; frames are then flipped and the casting procedure is repeated again for the lower electrode. Following casting, upper and lower frames are tightened together by using clamps to reduce chances of silicone elastomer film slippage.

As it can be seen from Figure 4, upper and lower casting masks are different. The overlap of the electrodes casted by means of them on the upper and lower surfaces of the silicone elastomer film defines the circular DET specimens, whereas the non-overlapping portions (hereafter referred to as “additional area for electrode connection”) are used to connect upper and lower electrodes to the external electrical supply circuit, which is done trough copper strips bonded on the polycarbonate frames (see Figure 1). DET specimen diameter is 20 mm, which is lower than the 25 mm of the frame holes. This enables the considered circular DET specimens to freely expand upon activation, which should improve lifetime according to previous findings [10].

3. TESTING SET-UP AND PROCEDURE

The set-up employed for specimen testing is the one described in [10]. The set-up enables:

- to test up to 16 identical DET specimens at the same time with general electric field waveforms but with no controlled force or displacement;
- to monitor and acquire DET specimen voltage and current with a sampling frequency of up to 10 kHz;
- fully automated operation, including automatic detection and isolation of broken DETs;
- galvanic isolation between high voltage and low voltage circuitry via isolated amplifiers and DC/DC converters.

The schematic of the electrical architecture of the set-up is given in Figure 5, which shows: high voltage power supply to energize the testing circuit; high voltage diode (D) to protect the power supply from current reversal; high voltage switches (S) to simultaneously charge and discharge the specimens, and to disconnect broken DET specimens right after failure; resistors (R) to limit the current flowing in the circuit branches during both specimen charging and discharging. A picture of the set-up during the testing of two batches of free-expanding frame-stretched circular DET specimens made of the

Wacker Elastosil® 2030 250/150 silicone elastomer film and with blade-casted carbon-black silicone-elastomer electrodes is provided in Figure 6.

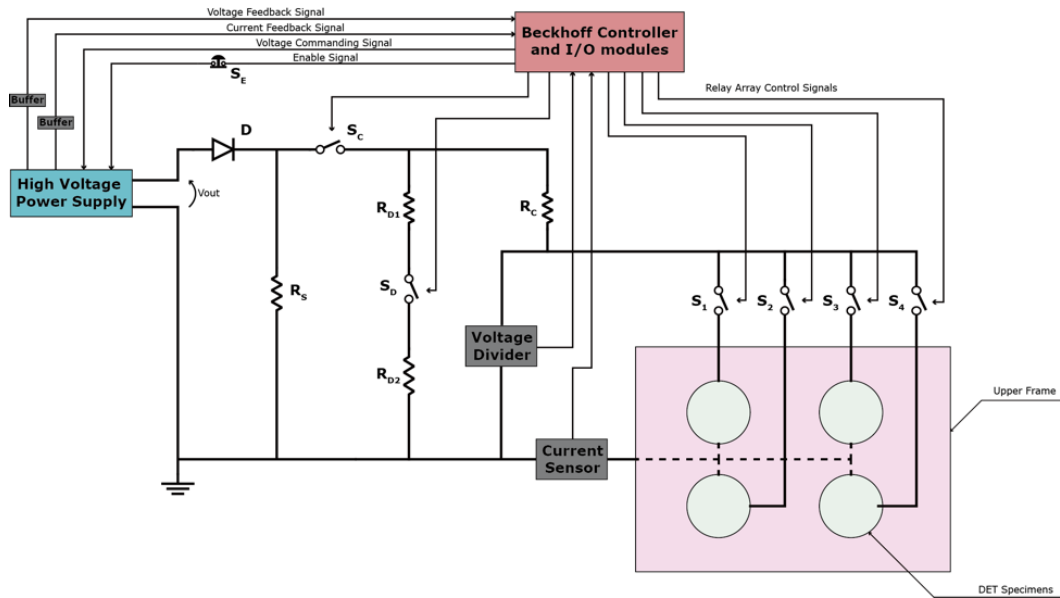

Figure 5. Schematic of the electrical circuit of the experimental set-up employed for lifetime testing; only 4 DET specimens are represented for simplicity.

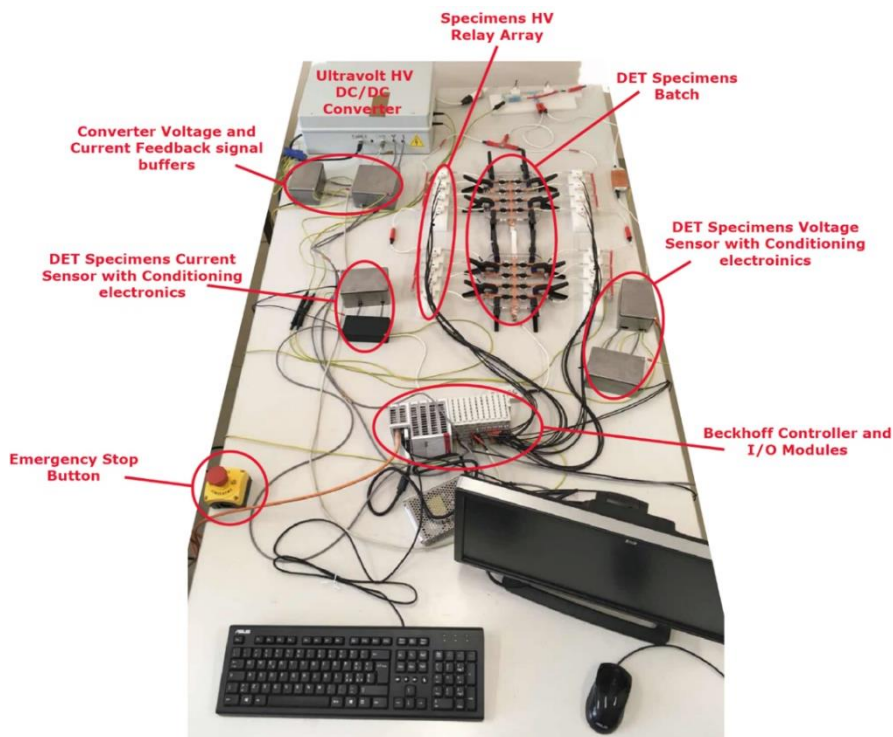

Figure 6. A picture of the experimental set-up during the lifetime testing of two batches of free-expanding frame-stretched circular DET specimens made of the Wacker Elastosil® 2030 250/150 silicone elastomer film and with blade-casted carbon-black silicone-elastomer electrodes.

that the manufactured silicone elastomer DET specimens are not sufficiently consistent, where the inconsistency is likely to be due to the procedure employed for electrode casting rather than be due to defects in the commercial silicone elastomer film. Still looking at Figure 7, another gap seems to exist around 10^2 cycles, but since the plotting is in logarithmic scale of lifetime, the gap at 10^5 cycles is much more significant (and, thus, more meaningful).

Upon visual examination of the failed specimens, three types of different ruptures have been observed as shown in Figure 8, with red circles indicating the location of breakdown points. In particular:

- Figure 8.a represents a silicone elastomer DET specimen with lifetime lower than 10^5 cycles. As it can be observed, the additional area of the upper electrode which is responsible for connecting the circular electrode to the electrical supply circuit (by means of copper strips visible in figure) is patterned poorly, which likely caused the early failure. The breakdown point is indeed located in this region, though not so obvious to be recognized with bare eyes.
- Figure 8.b represents another silicone DET specimen with lifetime lower than 10^5 cycles. The specimen seems fine regarding to the casted electrode pattern, but it still suffered from an early failure. Nonetheless, the breakdown point occurred again in the additional area for electrode connection outside the active region of the circular DET specimen.
- Figure 8.c represents a specimen with lifetime greater than 10^5 cycles. Electrodes seem fine as in the previous case, but the breakdown point, which is clearly visible as an opaque spot, lies at the border of the electrode and not in the additional connection area.

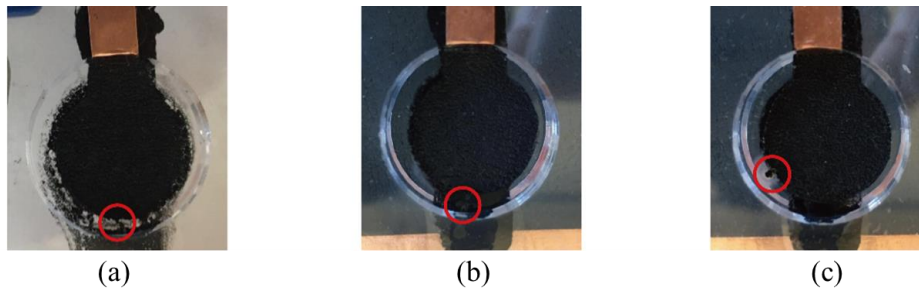

Figure 8. Examples of three types of failed free-expanding frame-stretched circular DET specimens made of the Wacker Elastosil® 2030 250/150 silicone elastomer film and with blade-casted carbon-black silicone-elastomer electrodes, with red circles indicating the breakdown points: (a) early failure of a specimen with imperfect electrode casting; (b) early failure of a specimen with not-obvious imperfection; (c) two-million-cycle failure of a good specimen. All of these DET specimens have been tested under the same electric field amplitude.

Early failures (namely, ruptures occurring before 10^5 cycles) occurred outside the active region of the circular DET specimen where the silicone elastomer film should not be stressed. This suggests that this kind of ruptures might be due to a poor patterning of the electrode, probably caused by not-sufficiently stirred carbon-black silicone-elastomer mixture or by an excessively slow curing process that prevented the mixture to bond adequately to the silicone elastomer film. In fact, in case only small concentrations of carbon-black remains in the casted area after drying and curing, electrode conductivity may become inhomogeneous and inconsistent, thereby creating very irregular electric fields upon DET activation, which is likely to lead to early failures. However, the quality of the electrode is not easy to verify, since as shown in Figure 8.b, the specimen seems fine, but it also exhibited an early failure. For a good specimen which has lasted more than 10^5 cycles, the plainness of the breakdown spot might instead indicate that the failure is indeed due to fatigue or degradation mechanisms: the weak point has been stressed sufficiently to change the material properties in the surrounding area.

To verify this observation, six specimens belonging to two different batches have been first preconditioned for 50000 cycles with an electric field amplitude of 65 MV/m; then, those that have survived have been tested with an electric field of 80 MV/m which is within the dielectric strength range of 80-100 MV/m declared in the Wacker Elastosil® 2030 250/150 datasheet for an unstretched film. Of these specimens, one failed immediately during the preconditioning cycle at 65 MV/m, whereas the remaining five specimens survived the preconditioning and exhibited the following response when

tested at 80 MV/m: one failed below 10^5 cycles, two of them failed at around 0.6 millions of cycles, and the last two of them reached about 1.8 millions of cycles and are still alive at the time of this writing. This additional test confirms that:

- there is indeed quality difference among the specimens even on the same batch;
- the defective specimens are not likely to last longer than 10^5 cycles, but the breakdown electric field levels for the defective specimens are not necessarily the same;
- the good specimens can easily last over 10^5 cycles.

Removing from Figure 7 the DET specimens with lifecycles lower than 10^5 (considered as defective specimens) provides Figure 9.

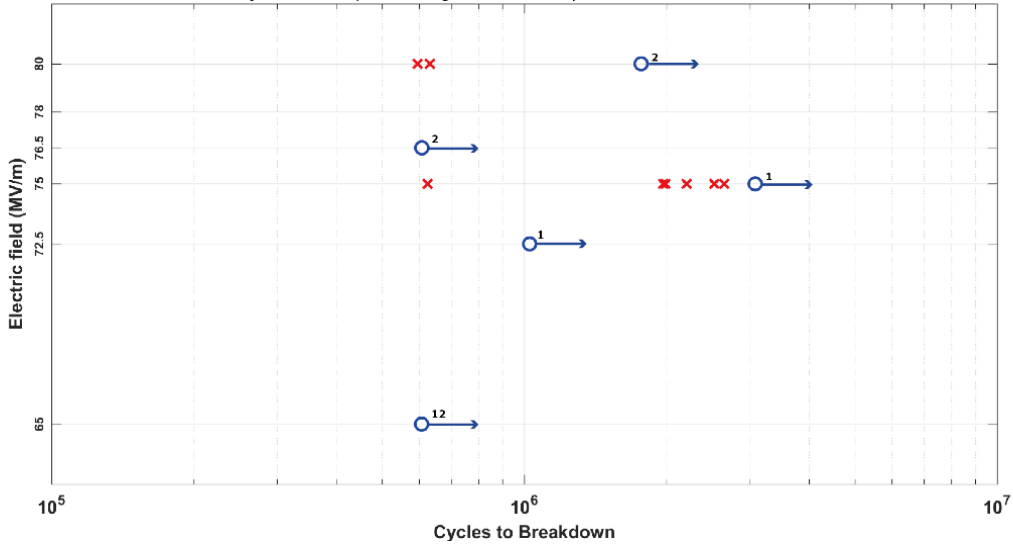

Figure 9. Lifetime results of non-defective (namely, that lasted more than 10^5 cycles) free-expanding frame-stretched circular DET specimens made of the Wacker Elastosil® 2030 250/150 silicone elastomer film and with blade-casted carbon-black silicone-elastomer electrodes. Red cross indicates failure; circle with right arrow indicates right censored specimens (still alive at the time of this writing); small number near the circle indicates how many specimens under the same condition.

Despite the limited number of data available for the non-defective DET specimens some statistical analysis can be done for the seven non-defective DET samples tested at an electric field amplitude of 75 MV/m whose lifetime data are summarized in Figure 10.a. Results are shown in the cumulative probability of failure plot reported in Figure 10.b, where:

- circle markers represent the experimental data, with the probability of failure of the i -th specimen (for $i = 1, \dots, n$; n being the number of tested specimens, here corresponding to $n = 7$) calculated as per the standard IEC 62539 with the formula

$$P_{\text{exp}}(i, n) = \frac{i - 0.44}{n + 0.25} \cdot 100\%$$

- the solid line represents the Weibull fitting of experimental data given by the following equation

$$P_w(N) = \left\{ 1 - \exp \left[- \left(\frac{N}{N_c} \right)^\beta \right] \right\} \cdot 100\%$$

with characteristic lifetime $N_c = 2204200$ and shape parameter $\beta = 3.76$ (more details on the Weibull model equation and on the procedure for the fitting of experimental data can be found in [10]);

- dashed lines represent the 95% confidence intervals calculated as suggested in [12].

Based on the Weibull fitting, the Mean Cycle To Failure (*MCTF*) of the seven considered free-expanding frame-stretched circular DET specimens, made of the Wacker Elastosil® 2030 250/150 silicone elastomer film with blade-casted carbon-black silicone-elastomer electrodes and tested at an electric field amplitude of 75 MV/m, results as [10]

$$MCTF = N_c \cdot \Gamma(1 + 1/\beta) = 1991000 \approx 2 \text{ millions of cycles}$$

where $\Gamma(\bullet)$ indicates the gamma function of its argument.

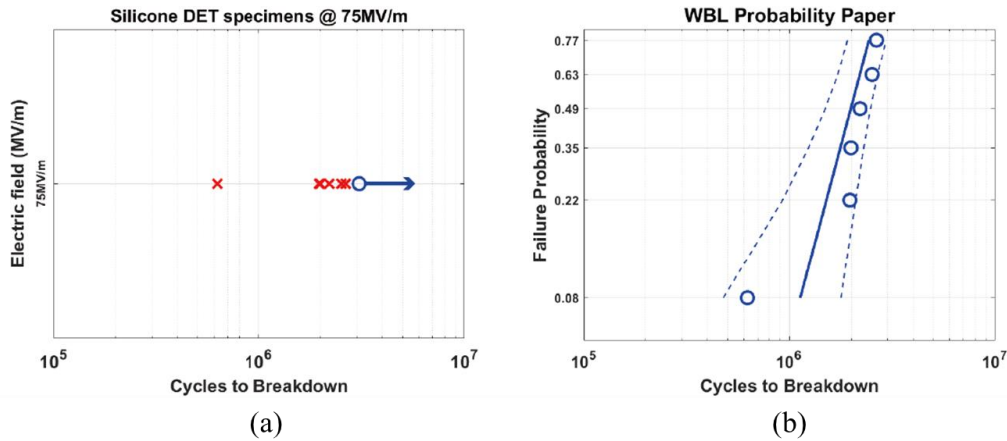

Figure 10. Lifetime results of free-expanding frame-stretched circular DET specimens, made of the Wacker Elastosil® 2030 250/150 silicone elastomer film and with blade-casted carbon-black silicone-elastomer electrodes, tested under 75MV/m along with the fitted distribution models plotted in: (a) log scale of lifetime, red crosses indicate failed specimens, circles with an arrow indicate specimens that are still alive at the time of this writing; (b) Weibull probability paper, with 95% confidence interval in lifetime as dashed lines, the fitted Weibull model as the straight lines and the experimental lifetime data as circle markers.

Owing to the large number of early failures experienced during the tests, the lifetime results described in this work can only be considered as preliminary and call for further investigations. Nonetheless, the reported 2 millions of cycles for the *MCTF* of non-defective DET specimens already confirm the Wacker Elastosil® 2030 250/150 silicone elastomer film as a very promising material for real-world DET applications, like for ocean wave energy harvesting [13].

5. CONCLUSIONS

This paper investigated the lifetime performances of free-expanding frame-stretched circular DET specimens made of the Wacker Elastosil® 2030 250/150 silicone elastomer film and with blade-casted carbon-black silicone-elastomer electrodes. After preparation of the DET samples in different batches, specimens have been subjected to constant electric-stress tests by using nearly square wave electric field signals with 1 Hz frequency, 50% duty cycle and with amplitudes ranging from 65 MV/m to 80 MV/m. Out of a total of 38 DET specimens tested, 12 exhibited an early failure (namely, they lasted less than 10⁵ cycles), which is likely to be due to the casting process used for electrode deposition, while the others survived more than 0.6 million of cycles (among which, four DET specimens lasted more than 2 millions of cycles). In particular, the specimens tested at an electric field amplitude of 75 MV/m demonstrated a Mean Cycle to Failure of around 2 millions of cycles, which is very promising for real-world applications.

Owing to the large number of early failures experienced, the results reported here should be regarded as only preliminary and further investigations are required, especially considering samples realized with more consistent processes for electrode deposition. Future investigations will focus on similar DET specimens made of the same Wacker Elastosil®

2030 silicone elastomer film, but with carbon-black silicone-elastomer electrodes realized by screen-printing and ink-jet printing.

6. ACKNOWLEDGEMENTS

The research leading to these results has received funding from the European Union Seventh Framework Programme (FP7/2007-2013), project PolyWEC, under Grant Agreement No. 309139, from the European Union Horizon 2020 Program, Project WETFEET, under grant no. 646436, from Tuscany Region (Italy) under the project EOLO (FAR FAS 2014-A) and from Wave Energy Scotland WES-PTO Programme under the project Direct Contact Dielectric Elastomer Generator PTO.

REFERENCES

- [1] Carpi, F., De Rossi, D., Kornbluh, R., Pelrine, R.E. and Sommer-Larsen, P. eds., (2011). Dielectric elastomers as electromechanical transducers: Fundamentals, materials, devices, models and applications of an emerging electroactive polymer technology. Elsevier.
- [2] Kornbluh, R. D., Pelrine, R., Pei, Q., Heydt, R., Stanford, S., Oh, S., Eckerle, J., (2002). Electroelastomers: applications of dielectric elastomer transducers for actuation, generation, and smart structures. In Proc. SPIE Vol. 4698, 254-270.
- [3] OHalloran, A., OMalley, F., McHugh, P., (2008). A review on dielectric elastomer actuators, technology, applications, and challenges. *Journal of Applied Physics*, 104(7), 071101-071101.
- [4] Pelrine, R., Kornbluh, R., Pei, Q., Joseph, J. (2000). High-speed electrically actuated elastomers with strain greater than 100%. *Science*, 287(5454), 836-839.
- [5] Madsen, F. B., Daugaard, A. E., Hvilsted, S., Skov, A. L. (2016). The Current State of Silicone-Based Dielectric Elastomer Transducers. *Macromolecular rapid communications*, 37(5), 378-413.
- [6] Shian, S., Huang, J., Zhu, S., Clarke, D.R. (2014). Optimizing the electrical energy conversion cycle of dielectric elastomer generators. *Advanced Materials*, 26(38), 6617-6621.
- [7] Kaltseis, R., Keplinger, C., Koh, S.J.A., Baumgartner, R., Goh, Y.F., Ng, W.H., Kogler, A., Tröls, A., Foo, C.C., Suo, Z., et al. (2014). Natural rubber for sustainable high-power electrical energy generation. *RSC Advances*, 4, 27905-27913.
- [8] Moretti, G., Righi, M., Vertechy, R., Fontana, M. (2017). Fabrication and test of an inflated circular diaphragm dielectric elastomer generator based on pdms rubber composite. *Polymers*, 9(7), 283.
- [9] Kornbluh, R., Wong-Foy, A., Pelrine, R., Prahlad, H., McCoy, B. (2010). Long-lifetime all-polymer artificial muscle transducers. *MRS Online Proceedings Library Archive*, 1271.
- [10] Chen, Y., Agostini, L. Moretti, G., Fontana, M., Vertechy, R. (2018). On the lifetime performances of a styrenic rubber membrane for dielectric elastomer transducers. *ASME Conference on Smart Materials, Adaptive Structures and Intelligent Systems*, paper #SMASIS2018-8143, San Antonio, Texas, 10-12 September 2018.
- [11] de Saint-Aubin, C. A., Rosset, S., Schlatter, S., Shea, H. (2018). High-cycle electromechanical aging of dielectric elastomer actuators with carbon-based electrodes. *Smart Materials and Structures*, 27(7), 074002.
- [12] Nelson, W. B. (2009). *Accelerated testing: statistical models, test plans, and data analysis* (Vol. 344). John Wiley & Sons.
- [13] Moretti G, Rosati Papini GP, Daniele L, Forehand D, Ingram D, Vertechy R, Fontana M. 2019 Modelling and testing of a wave energy converter based on dielectric elastomer generators. *Proc. R. Soc. A* 475: 20180566.