

Analysis of an Integrated Energy System Aimed at the Offshore Production of Methanol

Leonardo Bozzoli*, Mariasole Cipolletta, Valeria Casson Moreno, Valerio Cozzani

Alma Mater Studiorum - Università di Bologna, Dipartimento di Ingegneria Civile, Chimica, Ambientale e dei Materiali, via Terracini 28, 40131 Bologna, Italy
leonardo.bozzoli@unibo.it

The results of the offshore integration of fossil and renewable energy sources (RESs) to produce an energy vector, namely methanol, are discussed. The methodology developed and hereby presented, allowed at first the selection of the best technology for offshore RESs exploitation, where a near-to-decommissioning platform is used as an energy hub. Based on the availability of natural gas from the depleted reservoir, the most suitable process for offshore methanol production was chosen among various alternative innovative processes. The optimal mix for energy production was then identified by varying the number of converters for each RES. Finally, the methanol production process was designed on the basis of the available electric power, including a backup system based on natural gas, to perform RESs valley filling and to achieve a steady state process.

1. Introduction

The decommissioning of an offshore platform is the final step in its life cycle and consists of the total or partial removal of the installation, a technically complex and highly impacting process from both the environmental and economic standpoints (ICF International, 2015). Moreover, in the exploited reservoir, fossil sources may still be present, even if their production and transport to the shore may be not economically viable due to their low pressure or low flow rate, as for the case of strained offshore platforms (Tan et al., 2021).

The high number of decommissioning offshore platforms, e.g. 5048 in 2017 in the Gulf of Mexico (Kaiser, 2019) and 48 in 2021 in the United Kingdom Continental Shelf (UK) in the North Sea (GOV.UK, 2022), can be an opportunity to re-use structures for other applications (Ministry of Economic Development, 2019), for example, to create a hub for the production of renewable energy and synthetic fuels or energy vectors (Crivellari and Cozzani, 2020). Indeed, to produce energy vectors, carbon substrates are needed and some may be taken from the reservoir.

The offshore context represents an opportunity for the exploitation of RESs as wind, wave, tidal and sun, with several advantages compared to the onshore context, for example, a more stable energy intensity, a higher energy density and the availability of space without subtracting land for other uses (Dincer et al., 2021).

Among all energy vectors, methanol is one of the most promising (Schorn et al., 2021), thanks to its low carbon content and its physical characteristics at atmospheric conditions. Besides, it can also be used as a fuel, either blended with gasoline in conventional internal combustion engines or alone with minor devices modifications. Last but not least, methanol is a precursor largely used in the chemical and process industry (PubChem, 2022). In the literature, to the best of authors knowledge, there is not a comprehensive approach for the design of energy systems integrating the RESs available around an offshore platform to be exploited in the framework of Power to Liquid (P2L) processes. Yang et al. (2018) designed a gas-to-methanol process based on integration among methane, electricity and wind turbines to provide energy for the process. However, the study focused mostly on process design and carbon efficiency calculation.

The aim of the present study was the development of a new methodology to optimize renewable energy production from different RESs to support offshore methanol production through an innovative process. The proposed methodology was then applied to a case study (i.e. an offshore gas platform located in the north Adriatic Sea with natural gas residual flowrate). The following assumptions were made in the definition of the case study: the process energetic self-sustainability was reached through the available RESs (i.e. wind, wave

and sun) and the backup system, supposed to be fed by fossil fuels. The management of the electrical power excess produced by converters was considered out of scope of the present study, that focused on the assessment of the methanol production system.

2. Methodology

In this paragraph the methodology developed to obtain an optimized hybrid energy system for the self-sustained offshore production of methanol is described. It was divided into five steps, as shown in Figure 1.

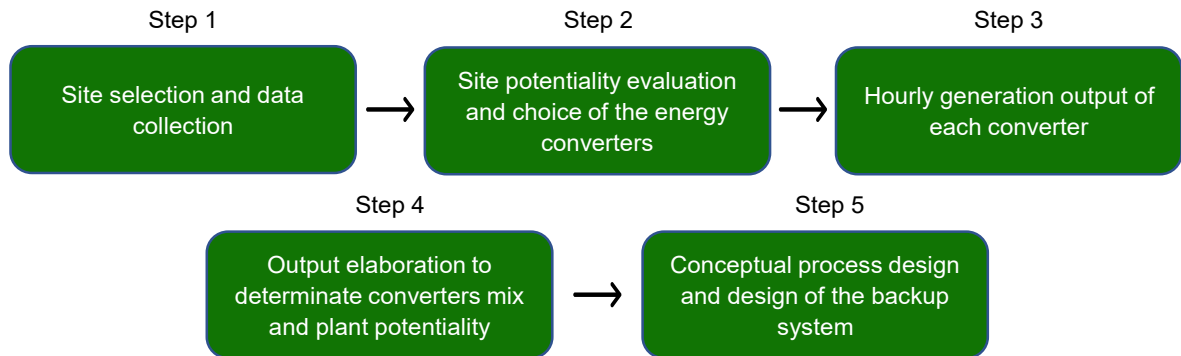

Figure 1: schematic representation of the proposed methodological steps.

At step 1, the offshore site has to be chosen and some considerations have to be done to drive this choice. Firstly, the choice of the site is related to the presence of a platform close to the decommissioning-phase; secondly, as reported in literature (Crivellari et al., 2021), CO₂ or CH₄ are needed as precursors to produce methanol through innovative processes, thus other important aspects were the composition and the flowrate of the residual gas from the reservoir. Actually, in case natural gas is not present in a sufficient amount, it had to be imported or produced on the platform. The last phase of the first step consists in checking the availability of meteo-climatic data related to the different RESs. Data collected must cover at least one year to investigate all seasonal variations, while timestep has to be one hour or lower due to RESs unpredictability.

The second step is the elaboration of the collected data to evaluate the energy potential of each source in the site. After that, the optimal converter is selected for each source, considering the potentiality and the operating conditions for which the converter was designed.

The third step is the calculation of the power production curves, according to both collected data and converters performance. For the solar power production, equations reported in (UNI, 2016) were used. The powers produced by the wind turbine (WT) and by the wave energy converter (WEC) are calculated using respectively power curve (Napolitano, 2021) and power matrix (Lejerskog et al., 2015) (as shown in section 4 of the present paper), two tools provided by constructors and specific for each converter. The tools work getting as input one or more site variables and providing in output the power produced by the converters; the input needed for the power curve is the wind speed while inputs needed for the power matrix are H_s (significant wave height, in m) and T_e (equivalent wave period, in s).

The fourth step of the methodology consists of (i) the elaboration of power production curves by each converter to determinate the optimal converters mix and (ii) the determination of process potentiality, two aspects strictly interconnected; indeed, given a mix of converters, a process characterized by a higher production capacity requires a more powerful backup system to act when RESs cannot sustain the process, resulting in a higher fossil fuel consumption. The elaboration of power production curves consisted on dividing the power produced by each converter in power classes, (e.g. class 1: 0-2 kW, class 2: 2-4kW,...), in order to identify: (i) the number of hours of power production per each power class, (ii) the number of hours of no power generation and (iii) the most frequent power class of power production for each converter as to evaluate the contribute that each converter could bring to the mix. Then, two parameters are calculated for several converters combinations and several power-thresholds related to the synthesis process, based on previous calculations: the number of hours in which converters are not able to fully sustain the process and the average power to be supplied to the process by the backup system during these time periods. The aim is to find the optimal compromise between the potentialities of the renewable generation system and of the methanol process, to reach the lowest fossil fuel utilization without oversizing the converters mix.

After determining the plant size, the last step consists in the conceptual design of the process through a software such as Aspen HYSYS. The design is implemented considering the offshore environment constraints (e.g. the temperature of seawater, if used as cooling). Then, the backup system is also designed, choosing the most

suitable option for the context, considering the available fossil sources and the nature of power required by the process (i.e. thermal or electric).

3. Case study characterization

To demonstrate the application of the proposed approach, an offshore natural gas platform in the Adriatic Sea was used as a case-study. The platform selected is Garibaldi C (Ministry of ecologic Transition, 2020), located 18 km off the coast of Ravenna, in the North Adriatic Sea. The choice was driven by two main reasons: (i) the availability of data of the flowrate natural gas and its composition (i.e. 846 kmol/d of almost pure methane) (Gamna, 2019), and (ii) the availability of data related to the exploitable RESs, provided by a metric wave buoy called Nausicaa, located 5.3 km from Ravenna coast.

The energy vector production process was selected starting from an accurate literature analysis focused on innovative processes for methanol synthesis. In the study by Crivellari et al. (2021), eleven innovative processes were reported. Nine of them are based on partial oxidation of methanol, while the others two are based on CO₂ hydrogenation. Given the reservoir fluid (high amount of CH₄ and low amount of CO₂) the process selected for methanol production was methane-based. Among all, the best option was the radical partial oxidation of methane in gaseous phase (Yarlagadda et al., 1988) thanks to its high yield (7.22 %), selectivity (76 %) and final concentration (6.6 % mol).

4. Results and discussion

Once the offshore platform was selected, the data for the exploitable RESs in the area were collected (according to step 1 of Figure 1). Sun, wind and wave energy were considered in the present study. The related hourly data were downloaded for a representative year (i.e. 2017). As mentioned in the previous paragraph, wave data collected from a metric wave buoy (Nausicaa) were obtained from the "Dext3r" database (Arpae, 2019). For solar radiation and wind speed (at the heights of 10 and 100 m, respectively) the European Centre for Medium-Range Weather Forecast (ECMWF, 2022) database was used.

The potentialities for each RES were calculated according to step 2 of the methodology. For the case of solar energy, total irradiation on a surface with optimal tilt (34°) was calculated equal to 5950 kJ/m²/y (the average irradiation from North to South in Italy ranges from 3500 kJ/m²/y to 6700 kJ/m²/y) (European Commission, 2022). After data elaboration for the two heights, Weibull distribution showed a low energy density: the yearly average wind speed at 10 m was 2.95 m/s and 4.21 m/s at 100 m height. Regarding the wave energy potential, the yearly average power was 1.02 kW/m, an extremely low value (Mørk et al., 2010). After the potentiality estimation, the second phase of step 2 consisted of the selection of energy converters. The high-efficiency photovoltaic (PV) panel called Maxeon 3 400 W (SunPower, 2019) was chosen. The WT choice was directed to the Goldwind GW/1500 PMDD (Goldwind, 2015), with a hub height of 85 m able to exploit the higher speeds at higher height, with a cut-in of 2.5 m/s, a parameter which enables to better exploit the low potentiality. The most suitable WEC for the given wave motion conditions was the L9 Lysekil (Lejerskog et al., 2015), a point absorber with a maximum power output of about 20 kW and a cut-in of H_s = 0.25 m and T_e = 2.5 s.

At step 3, the energy and the power produced from each single converter were calculated (as reported in Table 1). PV panels production was calculated considering 949 m² (platform area available for panels installation). Using the power curve of the WT (Figure 2b), for a given average hourly velocity, the average hourly power output was determined. A similar procedure was carried out for the point absorber converter, using data of H_s and T_e as input for the power matrix (Figure 2a) (Hong et al., 2016).

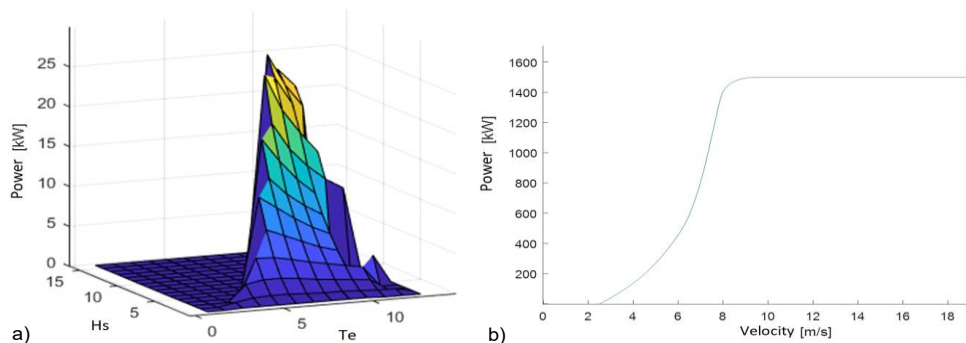

Figure 2: (a) L9 point absorber power matrix; (b) Goldwind WT power curve.

Table 1: Converters peak power and energy generation data in the studied year.

Converter	Peak power [kW]	Annual energy [MWh/y]	Yearly average power [kW]
PV panel	215	283	32.4
WT	1500	2580	294
WEC	20	5	0.58

In Figure 3, data of each converter elaborated as described in step 4 of the methodology are presented. Higher power class corresponds to higher power produced. The WEC and PV panels do not produce power for about half of the time. The WEC has the highest percentage of operating time in the two lowest power classes, due to low wave potentiality. The PV panels showed an increasing power production for increasing power classes. WT was the most operative converter due to a relatively low time of non-energy production (27 %). Then, to achieve the maximum exploitation of RESs without oversizing the converters mix (and therefore the backup system), in the second phase of step 4 several combinations of converters and process sizes were considered, as shown in Table 2. Four plant potentialities (60, 100, 200, 400 kW) and 4 converters combinations for the hybrid energy system (949 m² PV panels, 1 or 3 WTs, 10, 50 or 100 WECs) were considered. The number of hours in which the back-up system had to sustain (partially or fully) the process and the average power needed in those hours were calculated for each combination. Considering the results shown in Table 2, a configuration characterized by 60 kW of power available for the methanol process and sustained by 949 m² of PV panels, 1 WT and 50 WECs was selected as optimal.

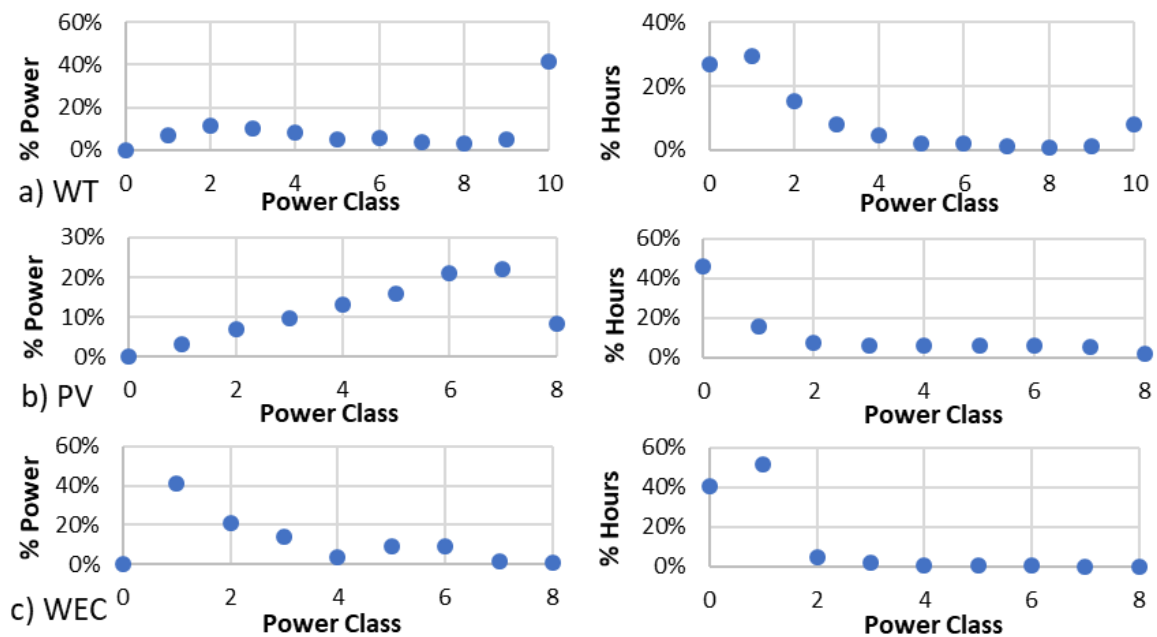

Figure 3: Power classes generation performance of each conversion device: (a) WT; (b) PV panels; (c) WEC. Per each power class, the power fraction produced on a yearly basis and the yearly generation frequency are displayed.

The fifth step was the process conceptual design starting from data reported in the literature (Yarlagadda et al., 1988). This step was carried out with Aspen HYSYS, obtaining both data regarding methanol production and required energy. An iterative process consisting in scaling HYSYS output data was carried out to size the process with the chosen potentiality, considering 10 % of power for auxiliaries. The final sizing resulted in 60 kW consisting of: 43.25 kW_i, 11.30 kW_e and 5.45 kW_e for auxiliaries. Methanol produced with 60 kW was 389 kg/d. The process flow sheet is shown in Figure 4. As expected, the power production of the proposed mix was not able to cover 100 % of the process energy requirements: 625 hours (7 % of the total running time) were not covered by the RESs.

Table 2: Possible configurations for the hybrid energy system. NE means not enough and \bar{P} is the average power to be supplied in the respective associate hours.

Configuration	Plant potentiality				
		60 kW	100 kW	200 kW	400 kW
949 m ² , 1 WT 1500, 10 WEC	n hours NE \bar{P} [kW]	2279 42.8	3227 64.1	5029 126.3	6607 276.2
949 m ² , 1 WT 1500, 50 WEC	n hours NE \bar{P} [kW]	2121 41.4	3060 62.4	4902 123.3	6499 272.1
949 m ² , 1 WT 1500, 100 WEC	n hours NE \bar{P} [kW]	2011 40.0	2876 61.7	4739 120.8	6366 268.1
949 m ² , 3 WT 1500, 100 WEC	n hours NE \bar{P} [kW]	1655 42.0	2207 67.0	3333 130.0	4443 274.0

The appropriate backup system had to be chosen given the energy requirements of the facilities (43.25 kW_t, 16.75 kW_e). A Combined Heat and Power generator Microturbine was chosen as a suitable system, and after checking the possible heat recovery from the exhaust stream, a microturbine with 30 kW_e and 60 kW_t of maximum power output was selected. Considering 2121 h/y of operation during which it has to partially or fully sustain the process (24.2 % of the year), with an average power supply of 41.4 kW, the backup system will consume 17950 kg of methane. This corresponds to 0.36 % of the amount extracted yearly from the well (at nominal potentiality, the micro-turbine would use 1.5 % of the total natural gas flow rate) and it will provide 16.7 % of total energy to the process.

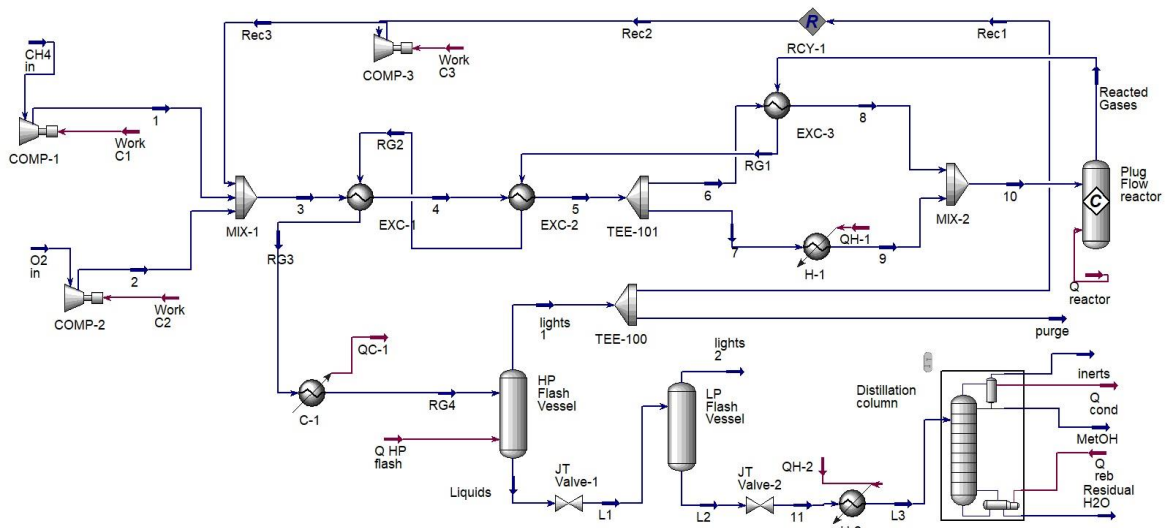

Figure 4: process scheme considered for the HYSYS simulations of methanol production.

The approach presented was applied to a case study chosen accordingly to the platform characteristics. However, it is important to remark that the RESs potentiality are very low in the geographical area considered. This was in part due to the position of the buoy, located at 5.3 km from the coast (the platform is 18 km from the coast), determining a lower density of wind and wave energy (Esteban et al., 2011). Also, the macro area had a negative influence on the process potentiality: indeed, the intake of wind and waves could be more significant in areas as the North Sea, or even more in oceans where the energy density of considered RESs is significantly higher.

5. Conclusions

This study aimed to prove the feasibility of an offshore hub for the production of methanol as energy vector using a hybrid fossil-RESs energy system. A case study to demonstrate the methodology is reported. Starting from the site selection, data of solar radiation, wind speed and wave characteristic were collected to evaluate the RESs potentiality. Then, converters for each RESs were selected. The nominal power of the integrated

renewable system and the size of the coupled methanol plant were found maximising the energy independence of the facility. After this, a back-up system was designed. Despite the low energy density of RESs in the site, the production of methanol was not negligible. The converter mix provided a satisfying power continuity showing a good integration of different RESs, limiting the operating time of the necessary backup system. On a more general basis, the approach presented provides a method to support decision making concerning offshore RESs exploitation re-using decommissioning platforms.

References

- Arpae, 2019, dext3r. <simc.arpae.it/dext3r/> accessed 11.11.2019.
- Crivellari A., Casson Moreno V., Cozzani V., Dincer I., 2021, Multi-criteria sustainability assessment of potential methanol production processes, *J. Clean. Prod.* 293, 126226.
- Crivellari A., Cozzani V., 2020, Offshore renewable energy exploitation strategies in remote areas by power-to-gas and power-to-liquid conversion, *Int. J. Hydrogen Energy* 45, 2936–2953.
- Dincer I., Cozzani V., Crivellari A., 2021, Offshore renewable energy options, *Hybrid Energy Syst. Offshore Appl.* 7–18.
- ECMWF, 2022, Climate Data Store. <cds.climate.copernicus.eu#!/home>
- Esteban M.D., Diez J.J., López J.S., Negro V., 2011, Why offshore wind energy?, *Renew. Energy* 36, 444–450.
- European Commission, 2016, UNI/TS 11300-4. Energy performance of buildings. Part 4: Renewable energy and other generation systems for space heating and domestic hot water production.
- Gamna V., 2019, Eni opens the doors of the Garibaldi C platform: the Italian Affairs tour (in Italian). <www.affaritaliani.it/economia/eni-benvenuti-sulla-garibaldi-c-596839.html> accessed 11.20.2020.
- Goldwind, 2015, Goldwind 1.5 MW 1888.
- Hong Y., Eriksson M., Boström C., Waters R., 2016, Impact of generator stroke length on energy production for a direct drivewave energy converter, *Energies* 9.
- ICF International, 2015, Decommissioning Methodology and Cost Evaluation 1–241.
- JRC Photovoltaic Geographical Information System (PVGIS) - European Commission, 2022. <re.jrc.ec.europa.eu/pvg_tools/en/> accessed 2.28.2022.
- Kaiser M.J., 2019, Gulf of Mexico Decommissioning Trends and Operating Cost Estimation Gulf of Mexico Decommissioning Trends and Operating Cost Estimation.
- Lejerskog E., Boström C., Hai L., Waters R., Leijon M., 2015, Experimental results on power absorption from a wave energy converter at the Lysekil wave energy research site, *Renew. Energy* 77, 9–14.
- Ministry of ecologic Transition, 2020, Italian Offshore platform. <unmig.mise.gov.it/index.php/it/dati/ricerca-e-coltivazione-di-idrocarburi/piattaforme-marine> accessed 2.15.2022.
- Ministro dello Sviluppo Economico, 2019, Guidelines for mining disposal of platforms for offshore hydrocarbons cultivation and related infrastructures (in italian).
- Mørk G., Barstow S., Kabuth A., Pontes M.T., 2010, Assessing the global wave energy potential, *Proc. Int. Conf. Offshore Mech. Arct. Eng. - OMAE* 3, 447–454.
- Napolitano F., 2021, System for the production and conversion of electrical energy 1–153.
- Oil and gas: decommissioning of offshore installations and pipelines - GOV.UK, 2022. <www.gov.uk/guidance/oil-and-gas-decommissioning-of-offshore-installations-and-pipelines> accessed 2.2.2022.
- PubChem, 2022, Methanol | CH₃OH - PubChem. <pubchem.ncbi.nlm.nih.gov/compound/Methanol#section=Use-and-Manufacturing> accessed 2.2.2022.
- Schorn F., Breuer J.L., Samsun R.C., Schnorbus T., Heuser B., Peters R., Stolten D., 2021, Methanol as a renewable energy carrier: An assessment of production and transportation costs for selected global locations, *Adv. Appl. Energy* 3, 100050.
- SunPower, 2019, Sunpower Maxeon 3 400 W. <sunpower.maxeon.com/it/sites/default/files/2019-09/sunpower-maxeon-3-modulo-residenziale-400-390-370.pdf> accessed 2.17.2022.
- Tan Y., Li H.X., Cheng J.C.P., Wang J., Jiang B., Song Y., Wang X., 2021, Cost and environmental impact estimation methodology and potential impact factors in offshore oil and gas platform decommissioning: A review, *Environ. Impact Assess. Rev.* 87, 106536.
- Yang S., Chen Q., Liu Z., Wang Y., Tang Z., Sun Y., 2018, Performance analysis of the wind energy integrated with a natural-gas-to-methanol process, *Energy Convers. Manag.* 173, 735–742.
- Yarlagadda P.S., Morton L.A., Hunter N.R., Gesser H.D., 1988, Direct conversion of methane to methanol in a flow reactor, *Ind. Eng. Chem. Res.* 27, 252–256.