



ALMA MATER STUDIORUM  
UNIVERSITÀ DI BOLOGNA

ARCHIVIO ISTITUZIONALE  
DELLA RICERCA

## Alma Mater Studiorum Università di Bologna Archivio istituzionale della ricerca

Experimental measurements of thermal-hydraulic performance of aluminum-foam water-to-air heat exchangers for a HVAC application

This is the final peer-reviewed author's accepted manuscript (postprint) of the following publication:

*Published Version:*

Dongellini, M., Naldi, C., Cancellara, S., Morini, G.L. (2022). Experimental measurements of thermal-hydraulic performance of aluminum-foam water-to-air heat exchangers for a HVAC application. *APPLIED THERMAL ENGINEERING*, 213, 1-10 [10.1016/j.applthermaleng.2022.118716].

*Availability:*

This version is available at: <https://hdl.handle.net/11585/898331> since: 2022-10-31

*Published:*

DOI: <http://doi.org/10.1016/j.applthermaleng.2022.118716>

*Terms of use:*

Some rights reserved. The terms and conditions for the reuse of this version of the manuscript are specified in the publishing policy. For all terms of use and more information see the publisher's website.

This item was downloaded from IRIS Università di Bologna (<https://cris.unibo.it/>).  
When citing, please refer to the published version.

(Article begins on next page)

This is the final peer-reviewed accepted manuscript of:

**Matteo Dongellini, Claudia Naldi, Stefano Cancellara, Gian Luca Morini**

***Experimental measurements of thermal-hydraulic performance of aluminum-foam water-to-air heat exchangers for a HVAC application***

**In: Applied Thermal Engineering, Volume 213, 2022, 118716**

**The final published version is available online at:**

<https://doi.org/10.1016/j.applthermaleng.2022.118716>

© 2022. This manuscript version is made available under the Creative Commons AttributionNonCommercial-NoDerivs (CC BY-NC-ND) 4.0 International License

(<http://creativecommons.org/licenses/by-nc-nd/4.0/>)

# **Experimental measurements of thermal-hydraulic performance of aluminum-foam water-to-air heat exchangers for a HVAC application**

*Matteo Dongellini\*, Claudia Naldi, Stefano Cancellara, Gian Luca Morini*

*Department of Industrial Engineering*

*Alma Mater Studiorum – University of Bologna*

*Viale del Risorgimento 2, 40136, Bologna, Italy*

\*Corresponding author:

Dr. Matteo Dongellini

Phone: +39 051 2090467

Fax: +39 051 2093296

E-mail: [matteo.dongellini@unibo.it](mailto:matteo.dongellini@unibo.it)

Other e-mails: [claudia.naldi2@unibo.it](mailto:claudia.naldi2@unibo.it); [stefano.cancellara@unibo.it](mailto:stefano.cancellara@unibo.it); [gianluca.morini3@unibo.it](mailto:gianluca.morini3@unibo.it)

## Abstract

In this paper, thermal and hydraulic performance of in-house made prototypes of water-to-air heat exchangers are experimentally investigated and compared to those of a compact heat exchanger, used in a commercial fan-coil. The prototypes are built replacing the fins with aluminum foam surfaces characterized by a large porosity, higher than 96%. In order to evaluate the performance of the foam-based heat exchangers in a real-scale application, the geometry of the prototypes was based on that of the reference model and, moreover, experimental tests were performed placing the heat exchangers within the commercial cabinet, under the same fan power. Different bonding techniques were also tested to couple metal foams to copper tubes. Results show that similar hydraulic performance can be obtained with the foam-based heat exchangers, if compared to the commercial device. However, the large foam porosity accounts for a lower value of the surface-to-volume ratio of the aluminum foam media, thus yielding a strong penalty, up to 60%, of the heat transfer rate with respect to that of the conventional finned surface. Moreover, experimental results highlight how the bonding technique and the foam packaging have a strong influence on the contact thermal resistance and, consequently, on the overall heat transfer coefficient. Epoxy bonding allows to increase the thermal performance of the heat exchanger, if compared to press fitting, between 15% and 110%. In conclusion, results presented in this paper suggest that metal foams can be considered as a potential alternative to fins in water-to-air heat exchangers only if the foam-tube bonding is obtained by welding or brazing.

**Keywords:** Water-to-air heat exchanger, metal foam, hydraulic performance, thermal performance, HVAC application, experimental.

## Nomenclature

$A$	Area	[m <sup>2</sup> ]
$C$	Parameter for the calculation of the effective metal foam thermal conductivity	
$c_p$	Specific heat at constant pressure	[J/(kg K)]
$D$	Diameter of tubes	[mm]
$d$	Average pore dimension	[mm]
$F_c$	Correction factor for cross-flow heat exchangers	
$G$	Specific air mass flow rate	[kg/(m <sup>2</sup> s)]

HEX	Heat exchanger	
$HTC_0$	Overall heat transfer coefficient of the heat exchanger with no extended surface	[W/(m <sup>2</sup> K)]
$K$	“Kebab packaging”	
$k$	Thermal conductivity	[W/(m K)]
$L$	Length	[mm]
$LMTD$	Logarithmic mean temperature difference	[K]
$m$	Fin parameter	
$\dot{m}$	Mass flow rate	[kg/s]
$N$	Number	
$OHTC^*$	Overall heat transfer coefficient of the heat exchanger	[W/(m <sup>2</sup> K)]
$p$	Pressure	[Pa]
PPI	Pores Per linear Inch	
$Q$	Air volumetric flow rate	[m <sup>3</sup> /h]
$R$	Thermal resistance	[m <sup>2</sup> K/W]
Re	Reynolds number	
$S$	“Sandwich packaging”	
$T$	Temperature	[°C]
$t$	Thickness	[mm]

#### *Greek symbols*

$\alpha_{sv}$	Surface-to-volume ratio	[m <sup>-1</sup> ]
$\beta$	Surface increase	
$\eta$	Fin efficiency	
$\eta'$	Correction factor for fin efficiency	
$\Phi$	Thermal power exchanged between water and air	[W]
$\varphi$	Metal foam porosity	[%]

#### *Subscripts*

$a$	Air
$b$	Base of fin/metal foam
$c$	Contact between fin/metal foam base and tube
$e$	External
$eff$	Effective
$f$	Fin
$fib$	Metal fiber
$front$	Frontal
$hex$	Heat exchanger
$i$	Internal
$in$	Inlet
$out$	Outlet
$s$	Metallic substrate
$t$	Tube
$tot$	Total
$w$	Water

#### *Superscripts*

*	Between base of fin/metal foam and air
---	--

## 1. Introduction

Heat exchangers (HEXs) are one of the main components of heating, ventilation and air-conditioning (HVAC) systems, which are responsible up to 40% of the total buildings' energy demand [1]. The optimization of the efficiency of HVAC components plays a significant role for reducing the environmental impact of these kind of systems. For this reason, researchers are investigating innovative techniques to enhance the thermal performance of heat exchangers, by improving overall heat transfer coefficients, with the aim to reduce heat transfer time, temperature levels and size of these components.

Different techniques and methods have been proposed to increase the thermal efficiency of heat exchangers, as summarized in recent review papers [2]-[8]. Fins [2], wavy surfaces [3], particle deposition [4], nanofluids [5], optimization of fluid dynamic fields [6], different kinds of inserts within the tubes [7] and manufactured metal lattices [8] have been applied to several typologies of heat exchanger; the effectiveness of these measures has been evaluated both experimentally and numerically.

Among the techniques proposed to improve the thermal performance of heat exchangers, the use of porous materials with open cells to replace conventional finned surfaces has received an increasing attention during the last decade [9]. These materials have evidenced remarkable features if used in heat exchangers due to their excellent mechanical characteristics, very high thermal conductivity and good ductility [10]. In addition, open-cell porous media are characterized by large values of the surface-to-volume ratio and by an internal structure which improves the fluid mixing [11]. On the other hand, the presence of the porous media is generally responsible of a non-negligible increase of pressure drops of the air stream [12].

Common HVAC components, such as heat pumps, radiators, electronic devices, fan-coils, use liquid-to-air heat exchangers in which the liquid flows within the tubes. In such systems, where the air-side thermal resistance is dominant representing up to 85% of the overall thermal resistance [13], metal

foams have been tested as alternative to the conventional finned surfaces with ambiguous results [14]-[17].

In order to study the thermal behavior of metal foams in contact with forced air flows, Dixit and Ghosh [18], Lai et al. [19] and Liu et al. [20] analyzed the thermal-hydraulic characteristics of open-cell metal foams coupled to plates at constant temperature. Dixit and Ghosh [18] developed a mathematical model able to predict the air temperature distribution at the exit of a heat exchanger built with copper foams sandwiched between plates kept at constant temperature. Results highlight how the governing equations for conventional fins can be used to estimate the heat transfer rate in presence of metal foams by introducing appropriate correction factors. Lai et al. [19] studied the influence of pore density and surface treatment on thermal-hydraulic performance of a copper foam block welded to a cold plate and crossed by a wet air flow. Their experimental results showed that hydrophilic metal foams perform better than untreated samples and hydrophilic fins. Liu et al. [20] predicted, by means of three-dimensional numerical models, the heat transfer coefficient and pressure drops in two heat exchangers composed by open-cell foam layers sintered on two substrate plates and cooled by a forced air flow. They demonstrated that their numerical model was able to accurately predict the available experimental data referred to metal foams coupled to heated plates.

During the last decade, a large number of numerical studies have been addressed to the optimization of tube bundles coupled with metal foams [21]-[24], since the most diffuse kind of liquid-to-air heat exchangers for HVAC systems is based on finned coils.

Mohammadpour-Ghadikolaie et al. [21] determined the thermal performance of a single tube, fully or partially wrapped by a porous metal layer, under laminar forced convection by means of a finite volume algorithm. They found that, the use of an external porous media can improve the Nusselt number up to 16 times, if compared to a bare tube, at high Reynolds numbers. Moreover, the heat transfer rate can be further increased up to 20% when only a partial cover of metal foam is adopted, thus reducing the material usage and weight. Hooman et al. [22] compared the thermal performance

of fins and metal foams as heat transfer enhancement techniques in tube bundles used as an air-cooled condenser. The influence of the tube spacing and tube bundle layout on the heat transfer rate was investigated through an analytical model, with the goal to minimize the pressure drops. Huisseune et al. [23] and Buonomo et al. [24] developed in similar works a two-dimensional numerical model, based on the Darcy-Forchheimer-Brinkman model, of metal foam blocks embedded with circular tubes and compared the thermal and hydraulic performance of the heat exchangers with those of commercially available models. Both studies confirm that a foam-based heat exchanger can outperform a conventional finned device, provided that the optimal values of the metal foam parameters, such as geometry, material and surface treatment, are selected.

Furthermore, several papers analyze the best trade-off between the improved thermal performance and the increased pressure drops obtained with metal foam heat exchangers. Chumpia and Hooman [25], for example, tested different sets of aluminum foam cylinders in two- and three-row bundles subject to cross airflow and benchmarked their performance with that of a conventional finned tube bundle. Their results illustrate how, with a optimized design strategy, the foam-wrapped heat exchanger ensures a significant enhancement of the heat transfer, keeping similar pressure drops. Chen et al. [26] carried out a similar experience on tube banks wrapped with metal foams and they found useful relations between the heat exchanger thermal performance and the foam parameters: Nusselt number increases when porosity increases and decreases for high density of pores at low Reynolds numbers.

In spite of the large number of works appeared in the open literature devoted to the analysis of material properties and transport phenomena in metal porous media, only a limited number of studies regarding the global performance of metal foam heat exchangers for HVAC applications can be found, as underlined by Dai et al. [27] among others.

In this frame, a worthwhile experimental work made by Kurian et al. [28] on three small-sized liquid-to-air heat exchangers has to be mentioned. The performance of devices composed by copper tubes

embedded with stainless steel wire meshes and press-fitted aluminum metal foam was experimentally tested and then compared with that of a reference bare tube device. Results point out that the mesh heat exchanger presents the best overall performance since the large thermal contact resistance of the foamed heat exchanger has a very strong negative influence on the overall heat transfer coefficient.

Another interesting study on different open-cell aluminum foam heat exchangers of cross-sectional area of 200 x 174 mm was conducted in a wind tunnel by Nawaz et al. [29]. Four different pore sizes and three methods to join foam and tubes were tested. The paper outlines that metal foams with a smaller pore size have a larger heat transfer coefficient compared to those with a larger pore size, while with larger pores smaller pressure gradients can be obtained.

A meaningful analysis of the performance of metal-foam heat exchangers for HVAC applications was published by De Schampheleire et al. [30]. They compared the thermal performance of two non-scaled heat exchangers, where the reference one was a commercially available high-quality louvered finned heat exchanger and the second one was an in-house prototype made by using a 10 PPI open-cell press-fitted aluminum foam. Their experimental results highlight how the contact resistance in porous metal heat exchangers accounts for more than 50% of the overall thermal resistance and, for this reason, the coupling between foams and tubes is a very sensible factor for the optimization of foam-based heat exchangers. These results confirm the observations by Sekulic et al. [31] and T'Joel et al. [32], who highlighted the presence of a high thermal contact resistance between metal foam and tubes in this kind of heat exchangers. Other authors [33] tried to use thermal greases in order to enhance the thermal contact but with no encouraging results. De Jaeger et al. [34] explored in detail the contribution of the contact resistance between foams and tubes by considering different bonding techniques (press-fitted tubes, glued tubes, brazed tubes); their paper evidence how the contact thermal resistance between foams and tube is the real bottleneck for a convenient application of metal foams to heat exchangers for HVAC applications.

The analysis of the open literature highlights that numerical works exceed the experimental ones in this field. Furthermore, in many cases the numerical analysis was conducted under “ideal” conditions, not accounting for the presence of thermal contact resistances, and/or by analyzing only a scaled portion of a real component. This can partially explain why there is not a fully agreement between the conclusions of many numerical works, which demonstrate how foam-based heat exchangers can outperform finned heat exchangers in terms of thermal performance, and the experimental data obtained for non-scaled components, which generally demonstrate how metal foams fail to improve the thermal performance of heat exchangers, at least for fixed pressure drops.

In order to make a large-scale application of foam-based heat exchangers feasible several technical challenges have to be handled: i) increase the number of experimental investigations on the role of the porous media features (e.g. porosity and pores density) on thermal/hydraulic performance of non-scaled heat exchangers; ii) test different bonding techniques between tubes and foams with the purpose to find a solution to the low thermal contact between tubes and porous metals.

With the aim to give a contribution in these directions, in this work a series of experimental tests on three real-scale prototypes of foam-based water-to-air heat exchangers are presented. Thermal and hydraulic performance of these prototypes are compared with those of a reference finned heat exchanger, used in a commercial fan-coil, under the same operative conditions. The heat exchanger prototypes, in-house made with 10 PPI open-cell aluminum foam, differ for the different bonding techniques adopted between tubes and foam, with the aim to investigate the role of the contact thermal resistance on the behavior of these devices. This work provides new insight into the adoption of foam-based heat exchangers in fan-coil terminal units, providing an experimental quantification of the differences between overall heat transfer coefficients and total thermal power exchanged by these kind of heat exchangers as a function of the adopted bonding technique.

## 2. The reference fan-coil

The water-to-air heat exchanger used in a commercial fan-coil (Galletti, model ESTRO F4) was considered as reference device for the experimental tests. A double-suction 3-speed centrifugal fan is mounted on the fan-coil and is directly coupled to an electric motor, mounted on vibration dampers. The dimensions of the fan-coil and of the commercial heat exchanger are reported in Figure 1 and are expressed in millimeters.

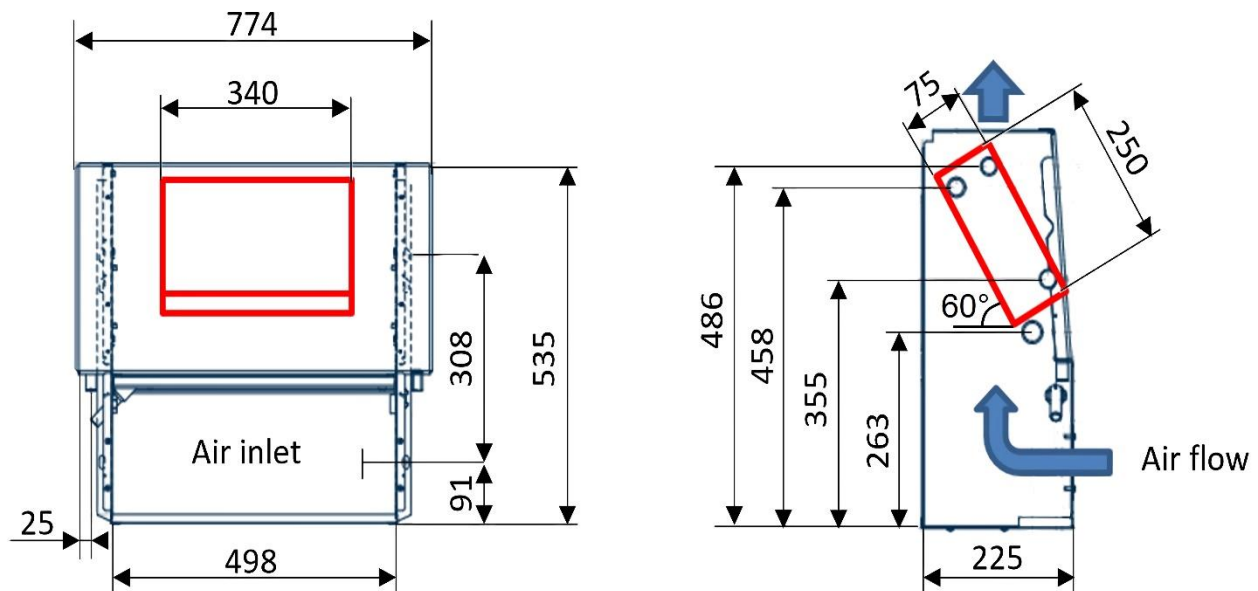

*Figure 1. Size and layout of the reference fan-coil. The red box represents the commercial water-to-air heat exchanger.*

The compact heat exchanger inserted within the fan-coil cabinet has three rows and is based on inline copper pipes mechanically coupled to aluminum plate fins. The heat exchanger has a total width of 340 mm, a height of 250 mm, a thickness of 75 mm and, as shown in Figure 1, is placed in a non-orthogonal position with respect to the air flow in order to reduce the overall fan-coil depth. As shown in the figure, the inclination angle of the heat exchanger with respect to the horizontal is equal to  $60^\circ$ . A series of 30 ( $N_t$ ) aligned copper tubes having an external diameter ( $D_e$ ) of 9.5 mm and organized in

two parallel hydraulic circuits composes the heat exchanger core. The base external area of the copper tubes is  $0.3052 \text{ m}^2$  ( $A_b$ ). The finned surface is obtained by means of a series of aluminum plate fins having a thickness of  $0.12 \text{ mm}$  ( $t_f$ ) and a constant pitch equal to  $1.6 \text{ mm}$ . The total number of fins along the width is equal to  $198$  ( $N_f$ ), while the surface-to-volume ratio ( $\alpha_{SV}$ ) of this compact heat exchanger is equal to  $1162 \text{ m}^2/\text{m}^3$ . Figure 2 shows the reference finned-tube heat exchanger inserted within the fan-coil cabinet.

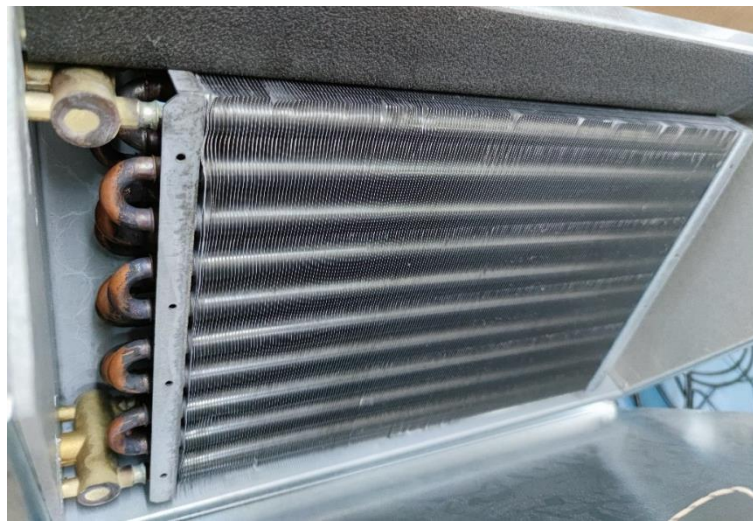

*Figure 2 – The reference water-to-air heat exchanger within the fan coil cabinet.*

The characteristic curves of the fan coupled to the commercial fan-coil were reconstructed experimentally within the test facilities of the fan-coil manufacturer, by considering the fan-coil cabinet and the non-orthogonal position of the heat exchanger with respect to the air flow. By varying the fan speed, the volumetric air flow rate across the heat exchanger varies from  $200$  to  $350 \text{ m}^3/\text{h}$ , corresponding to a variation of the air velocity from  $0.9 \text{ m/s}$  to  $2 \text{ m/s}$  at the exit of the reference fan-coil. Reynolds number, calculated with copper tubes external diameter as characteristic length, ranges between  $200$  and  $900$ . The maximum pressure drops of the air stream, obtained at the maximum air velocity, are around  $30 \text{ Pa}$ .

### 3. Built-in prototypes of metal foam heat exchangers

The aluminum foam selected for the replacement of the finned surface of the reference heat exchanger is characterized by a porosity ( $\phi$ ) of 96% and a pores density value close to 10 pores per linear inches (PPI). The metal foam used in this work, identified as AL-10-96, is the same used in [12], [30] and [34] and it was selected according to the results obtained by Cancellara et al. [12], who have measured the trend of the pressure drops across a fixed thickness of that porous metal as a function of the air velocity.

In Table 1, the geometrical characteristics of the metal foam declared by the manufacturer (i.e. pores density and porosity), the average dimension of the pores ( $d$ ) and the typical fiber thickness ( $t_{fib}$ ) are reported together with the surface-to-volume coefficient ( $\alpha_{SV}$ ). As observed by De Jaeger et al. [34], values of  $\alpha_{SV}$  between 300 and 600 are typically expected for 10 PPI aluminum foams, with a significant variability between different samples. The value of  $\alpha_{SV}$  used in this paper, namely 440  $m^2/m^3$ , is that considered by De Schampheleire et al. [30] for the same kind of foam obtained by the same manufacturer.

Both the values of pores density and porosity declared by the foam manufacturer were experimentally verified for each sample. The porosity of each specimen was measured by comparing the weight of the sample with the one expected for the sample volume filled by the solid material. The weight of the samples was measured by using an analytical balance (*RADWAG AS 220.R2*). Moreover, the density of pores was verified through acquisition of digital images of the foam surface by SEM. To assess the typical dimensions of the pores, their average distance and the thickness of the metal fibers, the digital images of the foams were numerically postprocessed by using the MATLAB Image Toolbox. The procedure followed in this work is the same described by Cancellara et al. in [12] and it is not repeated here for sake of brevity. The measured values ( $\phi=96.6\%$ , pores density 8-11 PPI) confirm the manufacturer indication, with a maximum deviation less than 1%.

Table 1 - Geometrical characteristics of the tested metal foam.

Tested foam	Porosity $\varphi$ [%]	Pores density [PPI]	$\alpha_{SV}$	$d/t_{fib}$
	Declared/measured	Declared/measured	[m <sup>2</sup> /m <sup>3</sup> ]	[mm]
AL-10-96	96/96.6	10/8-11	440	2.55/0.47

Three prototypes of metal foam heat exchangers have been built by coupling 10 PPI aluminum foams with the same copper tubes used in the reference fan-coil. The main technological problem encountered when a porous metal is bonded to a tube is linked to the optimization of the thermal contact between foam and tube. Different strategies can be followed: the tubes can be press-fitted between two plane foam sheets, like a “sandwich” (see Figure 3a), or the foam can be subdivided into a series of pieces which are impaled in the straight copper tubes, like a “kebab” (see Figure 3b).

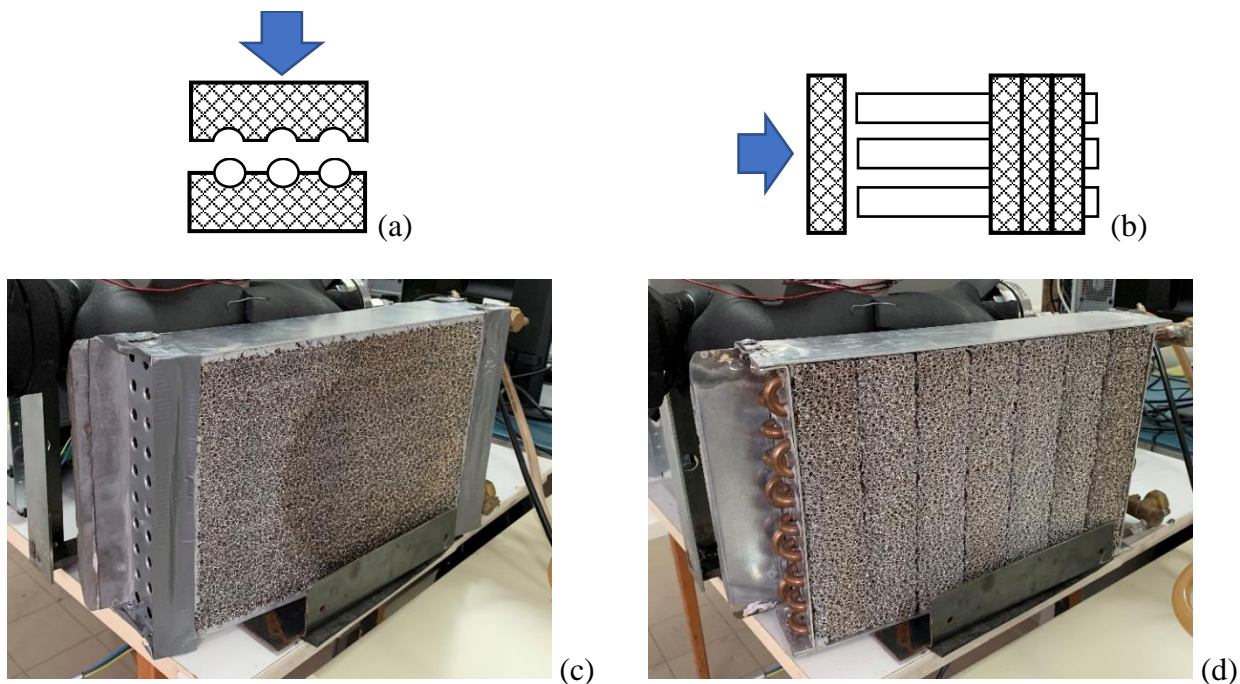

Figure 3 –Metal foam water-to-air heat exchangers built with “sandwich packaging” (S-type) (a, c) and “kebab packaging” (K-type) (b, d).

In Figure 3c the metal foam heat exchanger obtained with a “sandwich packaging” (S-type) is reproduced, while in Figure 3d that obtained with a “kebab packaging” (K-type) is shown.

In order to improve the thermal contact between tubes and foam, a thermo-conductive grease (*Loctite SI 100*) with a thermal conductivity of 3.4 W/mK or a bi-component epoxy-glue (*Loctite EA9497*), having thermal conductivity equal to 1.4 W/mK, were inserted between copper tubes and foam.

It is worth to mention that, the external dimensions of all the built-in foam-based heat exchangers are exactly the same of those of the reference one, described in the previous Section, in order to insert the prototypes within the commercial fan-coil cabinet. Moreover, the number of copper tubes (30) and the water hydraulic circuit are the same for all the tested heat exchangers. Conversely, the three in-house made metal foam heat exchangers differ in terms of tube-foam coupling (*K*-type or *S*-type) and for the presence of a thermo-conductive grease or an epoxy glue introduced between foam and tubes.

In Table 2 the main characteristics of each prototype are summarized. In this table,  $A_{front}$  is the frontal area of the heat exchanger (340×250 mm<sup>2</sup>) and  $t_{hex}$  is the thickness of the heat exchanger.

*Table 2 - Main characteristics of the foam-based heat exchangers.*

Prototype	$t_{hex}$ [mm]	$A_{front}$ [m <sup>2</sup> ]	Foam-tubes coupling	Paste thermal conductivity [W/mK]
S-type_grease	75	0.085	S-type	3.4 (grease)
K-type_grease	75	0.085	K-type	3.4 (grease)
S-type_glue	75	0.085	S-type	1.4 (epoxy-glue)

#### **4. Test rig and data reduction method**

In Figure 4 the experimental setup is shown. The fan-coil is equipped with a series of sensors in order to measure the main parameters for a complete characterization of the hydraulic and thermal performance of the inserted heat exchanger. The air flow through the fan-coil cabinet is varied by changing the electrical voltage of the fan motor via PC. Air flow rate across the heat exchanger is monitored by using a hot-wire anemometer (*TSI, VelociCalc® Plus mod. 8386A*) by means of which

a series of velocity values are obtained at the fan-coil exit. A differential micromanometer (*TSI, DP- Calc™ mod. 8710*) is used to measure the air pressure drops across the heat exchanger. Moreover, the air temperature at the fan-coil inlet and outlet is monitored by means of a series of K-type thermocouples.

The heat exchanger is fed with hot water from a thermostatic bath (*Julabo, mod. 26MC*), by means of which the inlet temperature can be fixed for each test. The water mass flow rate is measured by using a Coriolis mass flow meter (*Emerson, model Micro Motion R-Series*). All the sensor's signals are collected by a series of NI DAQ modules (*NI 9213 and NI 9219*) and shared with a PC by means of LabView.

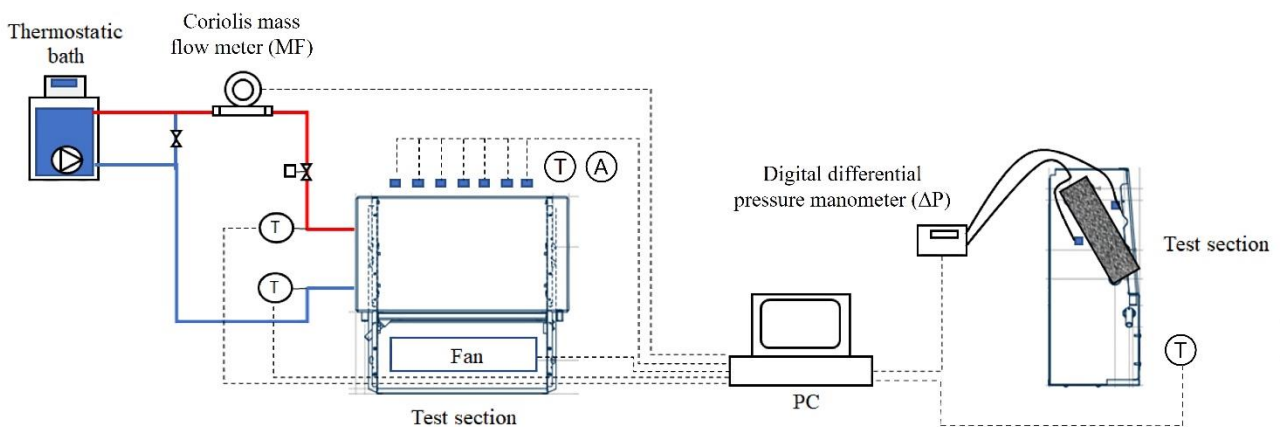

*Figure 4 - Layout of the experimental setup and position of sensors: T (thermocouple); MF (mass flow meter); A (hot wire anemometer);  $\Delta p$  (differential pressure manometer).*

To assess the accuracy of the experimental measures presented in this work, the uncertainty associated to each measurement device is reported in Table 3.

Table 3 - Characteristics and uncertainties of the measurement instruments

Instrument	Range	Uncertainty
TSI, VelociCalc® Plus mod. 8386A	0-50 m/s	±0.15 m/s or ±3% reading (the greater)
TSI, DP-Calc™ mod. 8710	0-3735 Pa	±2% full scale
Coriolis mass flow meter	0-150 kg/s	±0.4% reading
Thermocouple (K-type)	0-100°C	±0.5 K

The thermal power exchanged between air and water,  $\Phi$ , is obtained by considering a thermal balance on the water-side of the heat exchanger:

$$\Phi = \dot{m}_w c_{p,w} (T_{w,in} - T_{w,out}) \quad (1)$$

In Equation 1,  $\dot{m}_w$  and  $c_{p,w}$  are the water mass flow rate and specific heat capacity, respectively, while  $T_{w,in}$  and  $T_{w,out}$  are the water inlet and outlet temperature, respectively.

The overall heat transfer coefficient between base and air ( $OHTC^*$ ) is then obtained by the thermal power as follows, according to Mancin et al. [35]-[36]:

$$OHTC^* = \frac{\Phi}{A_b F_c LMTD} = \frac{\Phi}{A_b F_c \frac{(T_{w,in} - T_{a,out}) - (T_{w,out} - T_{a,in})}{\ln\left(\frac{T_{w,in} - T_{a,out}}{T_{w,out} - T_{a,in}}\right)}} \quad (2)$$

where  $LMTD$  is the logarithmic mean temperature difference between air and water at the inlets of the cross-flow heat exchanger,  $F_c$  is the correction factor for cross-flow heat exchangers (with unmixed flows for the reference heat exchanger) and  $A_b$  is the internal surface of the copper tubes exposed to the water flow:

$$A_b = N_t L_t \pi D_i \quad (3)$$

where  $N_t$  is the number of tubes (30),  $L_t$  is the length of the copper tubes exposed to the air flow (340 mm) and  $D_i$  is the internal diameter of each tube (7.92 mm).

Following the fin theory [35]-[36], the thermal power can be expressed as the sum of the heat exchanged across  $A_b$  and the heat exchanged across the surface of the metal foam in contact with the air flow (reduced by considering the efficiency  $\eta$  of the finned surface):

$$\Phi = HTC_0 A_b \left( 1 + \eta \alpha_{sv} \left( \frac{A_{front} t_{hex}}{A_b} - \frac{D_e}{4} \right) \right) \Delta T^* = HTC_0 A_b (1 + \eta \beta) \Delta T^* \quad (4)$$

where  $\Delta T^*$  is the temperature difference between the base of the fin/metal foam ( $T_b$ ) and the average air temperature.  $\Delta T^*$  is calculated by means of the following equation [37]:

$$\Delta T^* = T_b - \frac{(T_{a,in} + T_{a,out})}{2} = \left( \frac{(T_{w,in} + T_{w,out})}{2} - \Delta T_c \right) - \frac{(T_{a,in} + T_{a,out})}{2} \quad (5)$$

$T_b$  is here estimated by subtracting to the temperature of the tube surface (considered equal to the average temperature of water between inlet and outlet ports) the term  $\Delta T_c$ , linked to the contact thermal resistance between tube and fin/metal foam.  $\Delta T_c$  is the temperature difference existing between the external surface of the copper tubes and the surface of the fins/foam in contact with the tubes.

As evidenced by many Authors [30], the accurate evaluation of the thermal contact resistance between foam and tubes is a hard challenge. In fact, the average temperatures at the tube/foam and foam/air interfaces and the average heat flux through both interfaces must be known to calculate the contact resistance. In this paper, a value of  $\Delta T_c$  calculated from experimental data is associated to the heat exchangers as a function of the adopted bonding technique.  $\Delta T_c$  is estimated as the temperature difference existing between the external surface of the copper tubes (equal to the average water temperature between inlet and outlet ports of the heat exchanger) and the higher temperature recorded on the fins/foam in contact with the tubes.

Furthermore,  $HTC_0$  is the air-side heat transfer coefficient obtained by neglecting the presence of the extended surface (i.e. fins or metal foam).  $HTC_0$  can be estimated by using the Zukauskas correlation,

reported in [38] for air flows crossing a tube bank, by employing the following values of the coefficients:  $c=0.52$ ,  $m=0.5$ ,  $n=0.36$  [38]. In that correlation, the coefficient  $\beta$  represents the increase of the surface in contact with the air flow with respect to  $A_b$ . In this analysis,  $\beta$  is equal to 21.5 for the finned heat exchanger and to 8.1 for the metal foam heat exchangers. These values are calculated by considering the corresponding values of  $\alpha_{SV}$  for finned-based and metal foam-based heat exchangers, respectively.

Following Mancin et al. [35]-[36], if one introduces the parameter  $\eta'$ , evaluated as:

$$\eta' = \frac{1 + \eta\beta}{1 + \beta} \quad (6)$$

it is possible to write the thermal power as:

$$\Phi = HTC_0 \eta' A_b (1 + \beta) \Delta T^* \quad (7)$$

By comparing Eq. (7) with Eq. (2) it is possible to observe that:

$$OHTC^* = \frac{\eta'(1 + \beta) HTC_0 \Delta T^*}{F_c LMTD} \quad (8)$$

Eq. (8) highlights that the increase of the heat transfer coefficient with respect to the base value ( $HTC_0$ ) is due to the increase of the external surface of the heat exchanger in contact with the air flow ( $1 + \beta$ ), but a correction factor ( $\eta'$ ) is needed to take into account that the extended surface has not the same temperature of the tubes. The coefficient  $\eta'$  can be obtained by Eq. (8) and, as consequence, the fin efficiency  $\eta$  can be obtained by Eq. (6).

The uncertainty of all the derived quantities was estimated by following Figliola and Beasley [39], applying the theory of the propagation of errors to the uncertainty associated with the measurement of the single quantities. In the present case, the uncertainty on the air velocity is  $\pm 3\%$ , on the pressure gradient across the heat exchanger is of the order of  $\pm 3\%$ , on the thermal power exchanged between air and water is of the order of  $\pm 15\%$ , and on the overall heat transfer coefficient  $HTC_0$  is of the order of  $\pm 20\%$ .

## 5. Discussion of the results

### 5.1. Analysis of hydraulic performance

In the first stage of experimental measures, the air flow rate through the fan-coil was measured with the considered heat exchangers (i.e. the reference one and the built-in prototypes) introduced within the fan-coil cabinet. Experimental tests were performed taking into account two positions of the heat exchangers within the cabinet: i) heat exchangers tilted with respect to the air flow, with an angle of incidence equal to  $60^\circ$ ; ii) heat exchangers perpendicular to the air flow. Obtained results are reported in Figure 5a and Figure 5b, respectively. In those figures, the characteristic curves of the fan for different speeds (maximum, medium and minimum) and the heat exchangers working points are shown for different values of the air volumetric flow rate.

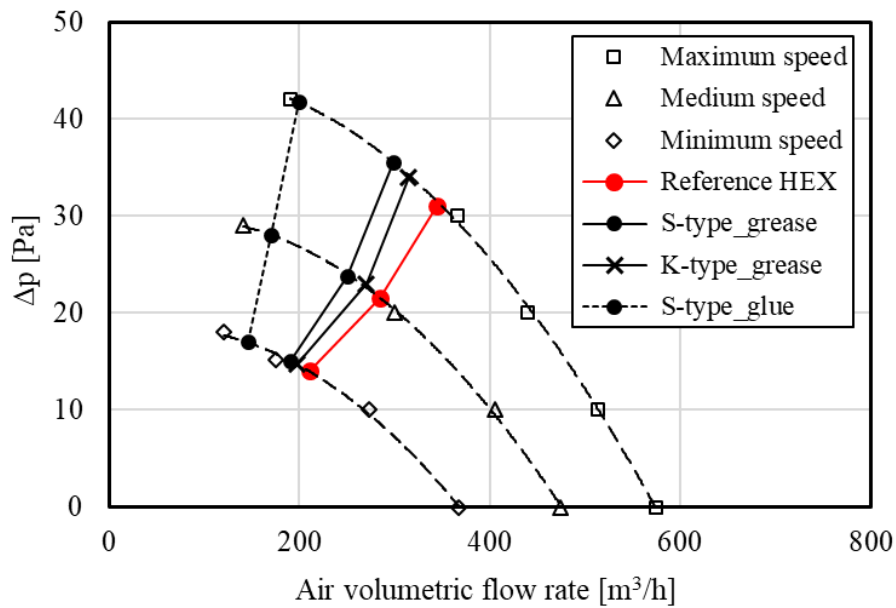

(a)

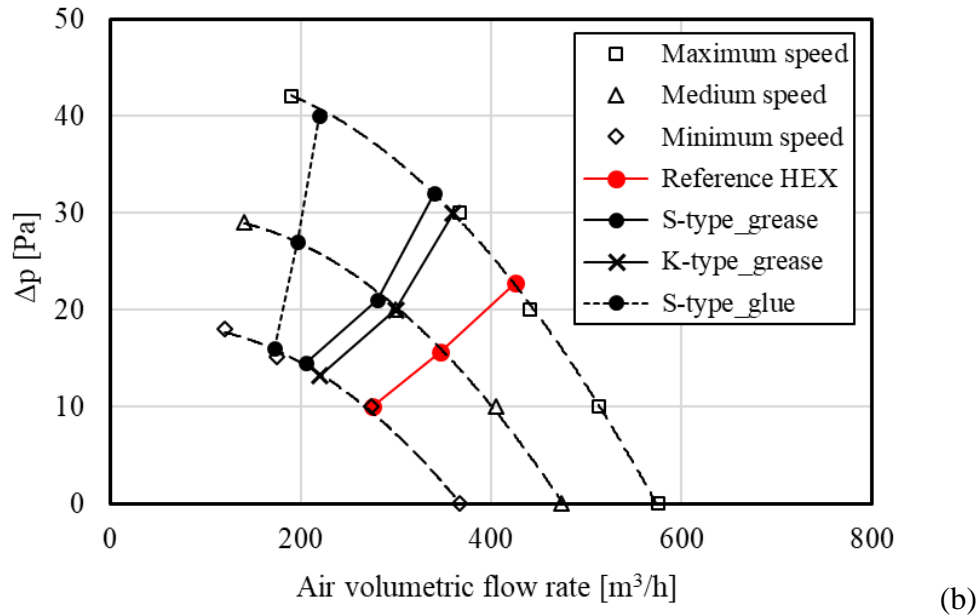

Figure 5 - Fan-coil working points with different positions of the heat exchanger within the cabinet: angle of inclination with respect to the horizontal equal to  $60^\circ$  (a) and equal to  $90^\circ$  (b).

From Figure 5 it is possible to observe that the pressure drops across the metal-foam heat exchangers have the same order of magnitude of those across the reference heat exchanger, but always larger. For example, when the heat exchangers are tilted with respect to the air flow, the air volumetric flow rate decreases from  $344 \text{ m}^3/\text{h}$  to  $298 \text{ m}^3/\text{h}$  when the maximum fan speed is selected and the built-in heat exchanger S-type\_grease is adopted, corresponding to a reduction of 13%. Moreover, experimental results point out that the air flow rate is reduced only by 7% if the heat exchanger K-type\_grease is used. In this case, the K-type packaging is responsible for a reduction of the pressure drops across the heat exchanger with respect to the S-type. This is mainly due to the presence of corridors between two consecutive layers of metal foam in the K-type (see Figure 3b), which can be seen as a series of by-pass paths for the air flow. By observing the position of the heat exchanger within the fan-coil cabinet, reported in Figure 1, it is evident that the air flow is not perpendicular to the metal foam: as pointed out by the drawings depicted in that figure, the heat exchanger is inclined with an angle of  $60^\circ$  with respect to the horizontal. The comparison between Figure 5a and 5b

highlights the increase of the pressure drops across the heat exchanger when the air flow is not perpendicular to the foam frontal area.

Another outcome from Figure 5 is that the epoxy-bonded prototype with *S*-packaging (*S*-type\_glue) presents larger pressure drops with respect to the other ones. In this case, in fact, in order to improve the thermal contact between foam and tubes, the foam sheets were squeezed against the copper tubes using the epoxy glue to improve the thermal contact. The layer of glue closed a series of pores around the tubes, thus decreasing the net flow passage for air. This increase of pressure drops across the heat exchanger significantly reduces the air flow rate across the fan-coil when the epoxy-bonded version *S*-type\_glue is considered: in this case, the volumetric air flow rate decreases up to 42% with respect to the commercial device.

### *5.2. Analysis of thermal performance*

The thermal power transferred from the hot water to the air flow was measured introducing the heat exchangers inside the fan-coil cabinet and varying the fan speed between maximum, medium and minimum value to obtain homogeneous comparisons. The heat exchangers were placed in the cabinet in a tilted position, with an angle of inclination with respect to the air flow equal to 60° (see Figure 1 for reference).

During the experimental tests, the heat exchangers were fed by a constant hot water flow rate of 84 kg/h with a temperature of 45°C, typical for fan-coil emitters during the winter season. The inlet air temperature was equal to the room temperature, ranging between 22°C and 23°C during the tests.

In Table 4, the thermal power transferred from the hot water to the air flow is reported for the four tested heat exchangers, placed in a tilted position within the cabinet, in correspondence of the different fan speeds. The variation of the thermal power of the built-in metal-foam heat exchangers with respect to the reference one is also reported.

Results highlight that the epoxy bonding and the press-fit *S*-type versions (*S*-type\_glue and *S*.type\_grease, respectively) work better with respect to the press-fit *K*-type prototype even if, in the case of the version *S*-type\_glue, the air flow rate across the heat exchanger is lower for a fixed speed of the fan. Among the two *S*-type versions, the presence of epoxy glue in *S*-type\_glue prototype is responsible for a larger reduction of the contact thermal resistance between the tubes and the metal foam, enhancing the thermal performance with respect to *S*-type\_grease version.

*Table 4 - Thermal power exchanged in correspondence of the three fan speeds [W] ( $\dot{m}_w=84$  kg/h,  $T_{w,in}=45^\circ\text{C}$ ,  $T_{a,in}=22^\circ\text{C}$ ).*

Fan speed	Reference HEX	S- type_grease	$\Delta$ (%)	K- type_grease	$\Delta$ (%)	S-type_glue	$\Delta$ (%)
Minimum	1178	590	-50.0	501	-57.5	664	-43.6
Medium	1313	637	-51.5	548	-58.3	695	-47.1
Maximum	1409	672	-52.3	570	-59.5	727	-48.4

From Table 4 it is also evident that, if the reference heat exchanger is replaced by the built-in prototypes, a significant decrease in terms of thermal power is observed (up to 59.5%). These results confirm the main conclusions of De Schampheleire et al. [30], who tested similar metal-foam heat exchangers, built with the same metal foam adopted in this work.

The observed thermal power reduction is due to a series of motivations. First, the larger pressure drops across the foam-based heat exchangers are responsible for the reduction of the air flow through the heat exchanger for a fixed value of the fan speed (see Figure 5). Furthermore, the reduction of the air velocity is significant across the prototype *S*-type\_glue; this evidence justifies the observed reduction of the thermal power up to 48.4% in correspondence of the maximum fan speed.

Secondly, the lower available heat transfer area of the foam with respect to the finned surface reduces the convective heat transfer rate. By considering the value of the surface-to-volume ratio of the aluminum foam used in these tests ( $\alpha_{SV}$  is equal to  $440 \text{ m}^2/\text{m}^3$ ), the air-side heat transfer area of the metal foam heat exchangers is estimated to be equal to  $2.8 \text{ m}^2$ . Conversely, the heat transfer area of the reference finned heat exchanger corresponds to  $7.4 \text{ m}^2$ , since in this case  $\alpha_{SV}$  is equal to  $1162 \text{ m}^2/\text{m}^3$ ). The difference in the heat transfer area between the heat exchangers is consequently around 60%, whose order of magnitude agrees with the observed thermal power reduction. It is worth to mention that the surface-to-volume ratio of the metal foam surface could be increased by selecting a foam with a lower porosity, but in this case the pressure drops across the heat exchanger increase, due to the reduction of the air cross section within the fan-coil. In such case, to maintain the same air flow rate, a more powerful fan should be used, with a consequent higher energy consumption. In conclusion, the adoption of metal foams could allow to obtain heat exchangers with very high surface-to-volume ratio values, but, with respect to conventional finned surfaces, such values can be reached only by accepting higher pressure drops.

In order to understand how much efficiently the heat is transferred from the copper tubes to the air stream, in Figure 6 the values of the overall heat transfer coefficient ( $OHTC^*$ ) of the heat exchangers tested in this work are reported in correspondence of minimum, medium and maximum fan speed, as a function of the specific air mass flow rate  $G$ . Error bars are shown for each experimental point, in order to highlight the uncertainty value ( $\pm 20\%$ ) associated to the calculated  $OHTC^*$ .

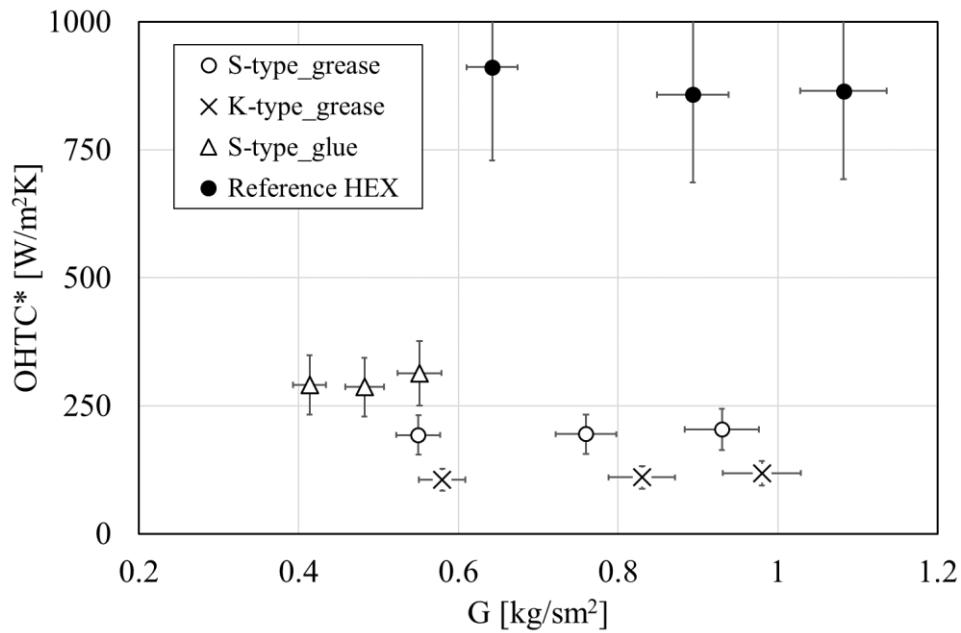

Figure 6 – Overall heat transfer coefficient for the tested heat exchangers as a function of the specific air mass flow rate.

It is important to stress that the correction factor  $F_c$  was calculated on the basis of inlet and outlet temperatures of both water and air streams, in correspondence of the three imposed settings of the fan speed. The value of  $F_c$  for the reference finned heat exchanger was estimated to be around 0.75 by considering a cross-flow heat exchanger with both fluids unmixed. A similar value was obtained for the epoxy-bonded heat exchanger (S-type\_glue), for which  $F_c$  is equal to 0.76. On the contrary,  $F_c$  assumes values between 0.94 and 0.98 for the press-fitted versions (S-type\_grease and K-type\_grease, respectively). It is important to stress that the correction factor was calculated for the foam-based heat exchanger by considering only the water side unmixed.

It is evident how the thermal performance of finned heat exchanger and built-in prototypes are significantly different. In fact, for foam-based heat exchangers the values of  $OHTC^*$  are lower than 350 W/m<sup>2</sup>K, while values of the order of 900 W/m<sup>2</sup>K can be obtained with the reference heat exchanger. Due to the higher pressure drops, the maximum specific air mass flow rate achievable with the epoxy-bonded prototype S-type\_glue at the maximum fan speed is equal to 0.55 kg/sm<sup>2</sup>

( $Re=450$ ). On the contrary, press-fitted *S*-type and *K*-type prototypes are able to work at similar air flow rate values as those of the reference heat exchanger, with a maximum specific air mass flow rate equal to  $1.08 \text{ kg/sm}^2$  ( $Re=870$ ). However, the press-fitted versions are characterized by  $OHTC^*$  values lower than those achieved with the epoxy-bonded version, even though the observed increase of the air flow rate. It is possible to claim that the thermal contact between tubes and foam has a more significant impact on the heat exchanger thermal performance than the airside resistance between the foam fibers and the air. This consideration clarifies why the increase of the air flow rate has a limited effect on the overall heat transfer coefficient.

Furthermore, the epoxy-bonded version *S*-type\_glue evidences  $OHTC^*$  values slightly higher than  $250 \text{ W/m}^2\text{K}$ , showing better thermal performance than the press-fitted prototypes, for which  $OHTC^*$  is limited to  $120 \text{ W/m}^2\text{K}$  (for *K*-type\_grease version) and  $220 \text{ W/m}^2\text{K}$  (for *S*-type\_grease prototype) at the maximum fan speed. Therefore, a lower contact thermal resistance might be obtained by using an epoxy bonding with respect to the press-fitting technique. In fact, a more efficient contact between the metal fibers and the tubes is guaranteed in presence of a high-conductive glue but, in some cases, the epoxy glue fills the pores and reduces the air passages, increasing the pressure drops. On the contrary, the press-fitted prototypes operate with similar pressure drops and air flow rates with respect to the reference heat exchanger, but they are able to reach only 24% (*S*-type\_grease) or 14% (*K*-type\_grease) of the overall heat transfer coefficient of the reference device for the same air flow rate. It is evident how the *K*-type packaging is not able to guarantee an optimal thermal contact between foam fibers and tubes. The presence of by-pass corridors between the foam pieces impaled along the tubes in the *K*-type packaging is the main reason for the reduction of both net convective heat transfer area and surface-to-volume ratio. In fact, the corridors increase the by-pass rate linked to the heat exchangers and, for this reason, a larger share of air stream avoids any thermal contact with the hot copper tubes. In conclusion, the *K*-type packaging is not a favorable solution to increase the thermal performance of water-to-air heat exchangers, regardless of the use of a thermo-conductive paste between foam fibers and tubes.

To obtain some information about the contact thermal resistance associated to the built-in prototypes, it is possible to observe how the inverse of  $OHTC^*$  represents the total thermal resistance existing between the hot water flowing in the copper tubes and the air stream. By considering as negligible the thermal resistance linked to the internal forced convection and to the heat conduction across the copper tubes, the total resistance can be considered as a sum of two components: i) the contact resistance ( $R_c$ ) between tubes and extended surfaces (fins or foam); ii) the convective resistance between the extended surfaces and the air.

*Table 5 – Total thermal resistance, contact thermal resistance and its weight for the tested heat exchangers.*

Tested HEX	$R_{tot}$ [ $m^2K/W$ ]	$R_c$ [ $m^2K/W$ ]	$R_c/R_{tot}$
Reference HEX	0.0010-0.0012	0.00019	14-18%
S-type_grease	0.0049-0.0052	0.0012	21-23%
K-type_grease	0.0085-0.0095	0.0035	38-40%
S-type_glue	0.0032-0.0034	0.0006	18-19%

In Table 5, the range of values of the total thermal resistance ( $R_{tot}$ ) and of the estimated contact thermal resistance ( $R_c$ ) are reported. Obtained data evidence how the total thermal resistance of the foam-based prototypes is from 300% (epoxy-bonded version) to 670% (press-fitted  $K$ -type version) higher with respect to the finned heat exchanger. The experimental results confirm that the contact resistance linked to the fin collars for the reference heat exchanger contributes to the total thermal resistance up to 14-18%. This percentage becomes equal to 21-23%, 38-40% and 18-19% for  $S$ -type press-fitted,  $K$ -type press-fitted and  $S$ -type epoxy-bonded metal-foam heat exchangers, respectively. These values are comparable with those measured and estimated by Kim et al. [40] and Jeong et al. [41] for fin collars, and by De Jaeger et al. [34] and De Schampheleire et al. [30] for foam-based heat exchangers. Conversely, it is expected that the presence of the metal foam on the air-side of the prototypes

promotes a better mixing of the air across the heat exchanger, improving the convective heat transfer coefficient. Nevertheless, this beneficial effect only partially compensates the reduction of heat transfer area, caused by the replacement of fins with metal foam surfaces and the increase of the contact thermal resistance.

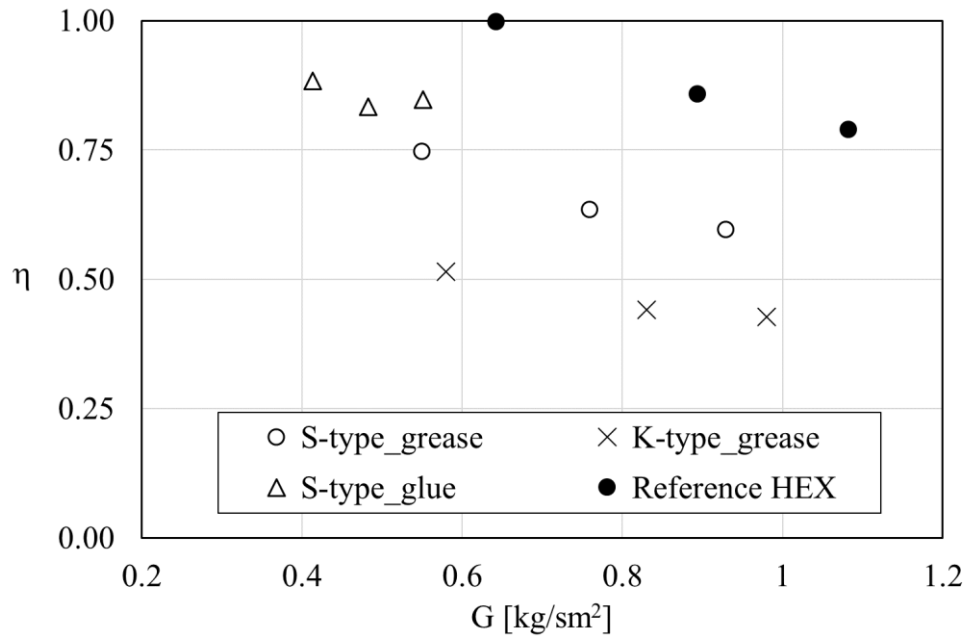

*Figure 7 - Fin efficiency for the metal foam heat exchangers and the reference heat exchanger as a function of the specific air mass flow rate.*

The fin efficiency  $\eta$  associated to the air-side surface of the tested heat exchangers is shown in Figure 7 as a function of the specific air flow rate. It is worth of mention that the metal foams coupled to the copper tubes with a *S*-type packaging are characterized by a larger value of the fin efficiency with respect to the foams bonded with a *K*-type packaging. However, the fin efficiency obtained with metal foams is always lower than that achieved with plate fins. Moreover, the observed reduction of fin efficiency is emphasized for high specific air flow rates.

In order to better explain this result, the conventional fin parameter  $m$ , which influences the extended surface efficiency in a heat exchanger, can be defined also for metal foam surfaces. More in detail, in a foam-based heat exchanger the parameter  $m$  indicates the ratio between the heat transferred by convection from the external surface of the metal foam to the air flow and the heat transferred by conduction from the tube surface to the solid fibers of the foam. The fin efficiency  $\eta$  is a monotonic decreasing function of  $m$ .

Dai et al. [27] proposed the following equation to determine the value of  $m$  for a foam-based heat exchanger:

$$m = \sqrt{\frac{HTC_0}{\alpha_{sv}k_{eff}}} \quad (9)$$

In Eq. (9) the heat conduction along the foam is calculated by considering the effective thermal conductivity of the foam ( $k_{eff}$ ). In the literature, an impressive amount of both numerical and empirical correlations for the calculation of  $k_{eff}$  can be found [42]. Nonetheless, since the thermal conductivity of air can be neglected with respect to that of metallic solid phase, the effective thermal conductivity of the metal foam can be expressed as a function of the porosity of the foam,  $\varphi$ , and the metallic substrate conductivity,  $k_s$ :

$$k_{eff} = Ck_s(1 - \varphi) \quad (10)$$

The value of the parameter  $C$  included in Eq. (10) depends on the selected correlation.

It is evident how a high metal foam porosity, needed to limit the pressure drops across the heat exchanger, implies a reduction of the effective thermal conductivity of the porous media. Moreover, the random pore distribution enhances both the mixing of the air and the convection heat transfer between solid fibers and air. These variations increase  $m$  and, consequently, the fin efficiency  $\eta$  decreases.

It is possible to conclude that the built-in prototypes of heat exchanger, in which the conventional fins are replaced by metal foam surfaces, have a lower thermal performance if compared to that of a commercial water-to-air heat exchanger for fan-coil applications. The main disadvantages of the in-house made heat exchangers are:

- the surface-to-volume ratio is lower than that of a traditional finned surface, if pressure drops similar to those of commercial heat exchangers have to be guaranteed;
- significant contact resistance values are present in foam-based heat exchangers;
- the equivalent fin efficiency for the metal foam surface is lower than that of a finned surface, due to the increase of the convective heat transfer coefficient and the reduction of the effective thermal conductivity associated to the metal foam.

## **6. Conclusions**

In this work, the hydraulic and thermal performance of three built-in heat exchangers, in which the conventional fins on the air-side are replaced by metal foam surfaces, are experimentally evaluated and compared to those of a commercial water-to-air heat exchanger for HVAC applications. Different packaging techniques and bonding methods were considered to couple metal foams to copper tubes: press-fitting and bonding with an epoxy glue.

The experimental results highlight that the adoption of metal foams with high porosity might guarantee similar pressure drops with respect to the conventional finned heat exchangers used in commercially-available fan-coils. Depending on the packaging used to couple metal foam surfaces and tubes, the air volumetric flow rate decreases between 7% and 13%, under the same fan power, when a thermo-conductive grease is adopted to enhance thermal contact between metal fibers and tubes. On the contrary, a strong reduction of the volumetric air flow rate, up to 42%, is observed for the epoxy-bonded version of the foam-based heat exchanger.

The results of this work demonstrate how the overall heat transfer coefficient of the built-in prototypes is significantly reduced with respect to the reference heat exchanger. In fact, high values of porosity are responsible for a lower surface-to-volume ratio of the foam-based extended surfaces, yielding a strong penalization on the heat transfer rate, up to 60%. Moreover, the small contact area between metal fibers and tubes proved to strongly increase the contact thermal resistance between metal foams and tubes and, consequently, the overall thermal performance of the heat exchanger is reduced. The total thermal resistance is also influenced by the bonding technique adopted to build the foam-based heat exchangers. Experimental data point out that the overall thermal resistance is about 300% and 670% higher, with respect to that of the reference heat exchanger, when epoxy bonding and press fitting are used, respectively. In fact, even if some pores are filled by the glue in the epoxy-bonded version, leading to an increase of pressure drops, a more efficient contact between metal fibers and tubes is ensured when epoxy bonding is adopted. With no epoxy glue, the hydraulic performance of the heat exchangers is slightly improved, while their thermal performance are further reduced.

In conclusion, this paper underlines that the replacement of the fins conventionally used in water-to-air heat exchangers with metal foam surfaces can be suitable only in presence of low specific air flow rates and a reduced contact thermal resistance between foam and tubes. In order to enhance the thermal contact between tubes and metal fibers, we are certain that the soldering method would be the best technique to couple copper tubes and metal foams. Nonetheless, this method is easily suitable with flat tubes, but several technological issues may arise in presence of tubes having a circular cross section. Therefore, the geometry of the whole heat exchanger should be revisited.

### **Acknowledgments**

This research has received funding in the frame of the Emilia-Romagna Regional development fund POR-FESR 2014-2020 Program under the NANOFANCOIL project.

## References

- [1] Z. Pang, Y. Chen, J. Zhang, Z. O'Neill, H. Cheng, B. Dong, Nationwide HVAC energy-saving potential quantification for office buildings with occupant-centric controls in various climates, *Applied Energy* 279 (2020) 115727.
- [2] A.A. Bhuiyan, A.K.M.S. Islam, Thermal and hydraulic performance of finned-tube heat exchangers under different flow ranges: A review on modeling and experiment, *International Journal of Heat and Mass Transfer* 101 (2016) 38-59
- [3] T.M.A. Elmaaty, A.E. Kabeel, M. Mahgoub, Corrugated plate heat exchanger review, *Renewable and Sustainable Energy Reviews* 70 (2017) 852-860.
- [4] A. Sadeghianjahromi, C. Wang, Heat transfer enhancement in fin-and-tube heat exchangers – A review on different mechanisms, *Renewable and Sustainable Energy Reviews* 137 (2021) 110470.
- [5] A. Hajatzadeh Pordanjani, S. Aghakhani, M. Afrand, B. Mahmoudi, O. Mahian, S. Wongwises, An updated review on application of nanofluids in heat exchangers for saving energy, *Energy Conversion and Management* 198 (2019) 111886.
- [6] N. Zheng, F. Yan, K. Zhang, T. Zhou, Z. Sun, A review on single-phase convective heat transfer enhancement based on multi-longitudinal vortices in heat exchanger tubes, *Applied Thermal Engineering* 164 (2020) 114475.
- [7] B. Kumar, G.P. Srivastava, M. Kumar, A. Kumar Patil, A review of heat transfer and fluid flow mechanism in heat exchanger tube with inserts, *Chemical Engineering & Processing: Process Intensification* 123 (2018) 126-137.
- [8] I. Kaur, P. Singh, Critical evaluation of additively manufactured metal lattices for viability in advanced heat exchangers, *International Journal of Heat and Mass Transfer* 168 (2021) 120858.
- [9] X. Yang, P. Wei, G. Liu, Q. Bai, Y. He, Performance evaluation on the gradient design of pore parameters for metal foam and pin fin-metal foam hybrid structure, *Applied Thermal Engineering* 175 (2020) 115416.

- [10] T. Wan, Y. Liu, C. Zhou, X. Chen, Y. Li, Fabrication, properties, and applications of open-cell aluminum foams: A review, *Journal of Materials Science & Technology* 62 (2021) 11-24.
- [11] X. Yang, P. Wei, X. Wang, Y. He, Gradient design of pore parameters on the melting process in a thermal energy storage unit filled with open-cell metal foam, *Applied Energy* 268 (2020) 115019.
- [12] S. Cancellara, M. Greppi, G. Fabbri, M. Dongellini, C. Biserni, G.L. Morini, Experimental Investigation on the Pressure Drop of Air Flows Through Aluminum and Nickel-Chromium Metallic Foams for HVAC Applications, *Energies* 13 (2020) 172.
- [13] M.A. Arie, D.M. Hymas, F. Singer, A.H. Shooshtari, M. Ohadi, An additively manufactured novel polymer composite heat exchanger for dry cooling applications, *International Journal of Heat and Mass Transfer* 147 (2020) 118889.
- [14] X.H. Han, Q. Wang, Y.G. Park, C. T'Joen, A. Sommers, A. Jacobi, A Review of Metal Foam and Metal Matrix Composites for Heat Exchangers and Heat Sinks, *Heat Transfer Engineering* 33 (12) (2012) 991-1009.
- [15] A. Muley, C. Kiser, B. Sundén, R. K. Shah, Foam Heat Exchangers: A Technology Assessment, *Heat Transfer Engineering* 33 (1) (2012) 42-51.
- [16] S. Rashidi, M.H. Kashefi, K.C. Kim, O. Samimi-Abianeh, Potentials of porous materials for energy management in heat exchangers – A comprehensive review, *Applied Energy* 243 (2019) 206-232.
- [17] L. Tadrist, M. Miscevic, O. Rahli, F. Topin, About the use of fibrous materials in compact heat exchangers, *Experimental Thermal and Fluid Science* 28 (2004) 193-199.
- [18] T. Dixit, I. Ghosh, An experimental study on open cell metal foam as extended heat transfer surface, *Experimental Thermal and Fluid Science* 77 (2016) 28-37.
- [19] Z. Lai, H. Hu, G. Ding, Influence of pore density on heat transfer and pressure drop characteristics of wet air in hydrophilic metal foams, *Applied Thermal Engineering* 159 (2019) 113897.

- [20] H. Liu, Q.N. Yu, Z.G. Qu, R.Z. Yang, Simulation and analytical validation of forced convection inside open-cell metal foams, *International Journal of Thermal Sciences* 111 (2017) 234-245.
- [21] M. Mohammadpour-Ghadikolaie, M. Saffar-Avval, Z. Mansoori, N. Alvandifar, N. Rahmati, Heat Transfer Investigation of a Tube Partially Wrapped by Metal Porous Layer as a Potential Novel Tube for Air Cooled Heat Exchangers, *Journal of Heat Transfer – Trans. ASME*, 141 (2019) 011802.
- [22] K. Hooman, X. Huang, F. Jiang, Solar-Enhanced Air-Cooled Heat Exchangers for Geothermal Power Plants, *Energies* 10 (2017) 1676.
- [23] H. Huisseune, S. De Schampheleire, B. Ameel, M. De Paepe, Comparison of metal foam heat exchangers to a finned heat exchanger for low Reynolds number applications, *International Journal of Heat and Mass Transfer* 89 (2015) 1-9.
- [24] B. Buonomo, A. Di Pasqua, O. Manca, S. Nardini, Evaluation of thermal and fluid dynamic performance parameters in aluminum foam compact heat exchangers, *Applied Thermal Engineering* 176 (2020) 115456.
- [25] A. Chumpia, K. Hooman, Performance of tubular aluminum foam heat exchangers in multiple row bundles, *Journal of Thermal Analysis and Calorimetry* 135 (2019) 1813-1822.
- [26] K. Chen, L. Guo, X. Xie, W. Liu, Experimental investigation on enhanced thermal performance of staggered tube bundles wrapped with metallic foam, *International Journal of Heat and Mass Transfer* 122 (2018) 459-468.
- [27] Z. Dai, K. Nawaz, Y. Park, Q. Chen, A.M. Jacobi, A Comparison of Metal-Foam Heat Exchangers to Compact Multilouver Designs for Air-Side Heat Transfer Applications, *Heat Transfer Engineering* 33 (1) (2012) 21-30.
- [28] R. Kurian, C. Balaji, S.P. Venkateshan, Experimental investigation of near compact wire mesh heat exchangers, *Applied Thermal Engineering* 108 (2016) 1158-1167.
- [29] K. Nawaz, J. Bock, A.M. Jacobi, Thermal-hydraulic performance of metal foam heat exchangers under dry operating conditions, *Applied Thermal Engineering* 119 (2017) 222-232.

- [30] S. De Schampheleire, P. De Jaeger, H. Huisseune, B. Ameel, C. T'Joel, K. De Kerpel, M. De Paepe, Thermal hydraulic performance of 10 PPI aluminium foam as alternative for louvered fins in an HVAC heat exchanger, *Applied Thermal Engineering* 51 (2013) 371-382.
- [31] D.P. Sekulic, Y.M. Dakhoul, H. Zhao, W. Liu, Aluminum foam compact heat exchanger: brazing technology development vs. thermal performance, *Proc. of the International Symposium on Cellular Metals for Structural and Functional Applications (CELLMET2008)*, Fraunhofer Center, Dresden, Germany, (2008) 5-10.
- [32] C. T'Joel, P. De Jaeger, H. Huisseune, S. Van Herzeele, N. Vorst, M. De Paepe, Thermo-hydraulic study of a single row heat exchanger consisting of metal foam covered round tubes, *International Journal of Heat and Mass Transfer* 53 (15-16) (2010) 3262-3274.
- [33] Y.L. Jamin, A.A. Mohamad, Natural convection heat transfer enhancements from a cylinder using porous carbon foam: experimental study, *J. Heat Transfer - Trans. ASME* 130 (2008) 122502-(1-6).
- [34] P. De Jaeger, C. T'Joel, H. Huisseune, B. Ameel, M. De Paepe, An experimentally validated and parameterized periodic unit-cell reconstruction of open-cell foams, *Journal of Applied Physics* 109 (2011) 103519.
- [35] S. Mancin, C. Zilio, A. Cavallini, L. Rossetto. Heat transfer during air flow in aluminum foams, *International Journal of Heat and Mass Transfer* 53 (2010) 4976-4984.
- [36] S. Mancin, C. Zilio, A. Diani, L. Rossetto, Air forced convection through metal foams: Experimental results and modeling, *International Journal of Heat and Mass Transfer* 62 (2013) 112-123.
- [37] T.L. Bergman, F.P. Incropera, A.S. Lavine, D.P. Dewitt. *Introduction to heat transfer: John Wiley & Sons* (2011).
- [38] A. Zukauskas, Heat Transfer from Tubes in Crossflow, *Advances in Heat Transfer* 8 (1972) 93-160.

- [39] R.S. Figliola, D.E. Beasley, Theory and Design for Mechanical Measurements, New York: John Wiley & Sons, 2009.
- [40] C.N. Kim, J. Jeong, B. Youn, Evaluation of thermal contact conductance using a new experimental-numerical method in fin-tube heat exchangers, International Journal of Refrigeration 26 (2003) 900-908.
- [41] J. Jeong, C.N. Kim, B. Youn, A study on the thermal contact conductance in fin-tube heat exchangers with 7 mm tube, International Journal of Heat and Mass Transfer 49 (2006) 1547-1555.
- [42] P. Ranut, On the effective thermal conductivity of aluminum metal foams: Review and improvement of the available empirical and analytical models, Applied Thermal Engineering 101 (2016) 496-524.