



ALMA MATER STUDIORUM
UNIVERSITÀ DI BOLOGNA

ARCHIVIO ISTITUZIONALE
DELLA RICERCA

Alma Mater Studiorum Università di Bologna Archivio istituzionale della ricerca

A Dual Frequency Blade Antenna Enabling UAV-Based Operations in ADS-B and 5G Environments

This is the final peer-reviewed author's accepted manuscript (postprint) of the following publication:

Published Version:

Arpaio, M.J., Fuschini, F., Masotti, D. (2021). A Dual Frequency Blade Antenna Enabling UAV-Based Operations in ADS-B and 5G Environments. Piscataway, NJ : IEEE [10.1109/ICUAS51884.2021.9476703].

Availability:

This version is available at: <https://hdl.handle.net/11585/828536> since: 2021-09-06

Published:

DOI: <http://doi.org/10.1109/ICUAS51884.2021.9476703>

Terms of use:

Some rights reserved. The terms and conditions for the reuse of this version of the manuscript are specified in the publishing policy. For all terms of use and more information see the publisher's website.

This item was downloaded from IRIS Università di Bologna (<https://cris.unibo.it/>).
When citing, please refer to the published version.

(Article begins on next page)

This is the final peer-reviewed accepted manuscript of:

M.J. Arpaio, F. Fuschini, D. Masotti, "A Dual Frequency Blade Antenna Enabling UAV-Based Operations in ADS-B and 5G Environments, 2021 International Conference on Unmanned Aircraft Systems (ICUAS), Athens (GR), June 15-18, 2021

The final published version is available online at: [10.1109/ICUAS51884.2021.9476703](https://doi.org/10.1109/ICUAS51884.2021.9476703)

Rights / License:

The terms and conditions for the reuse of this version of the manuscript are specified in the publishing policy. For all terms of use and more information see the publisher's website.

This item was downloaded from IRIS Università di Bologna (<https://cris.unibo.it/>)

When citing, please refer to the published version.

A Dual Frequency Blade Antenna Enabling UAV-Based Operations in ADS-B and 5G Environments *

Maximilian James ARPAIO, Franco FUSCHINI, Diego MASOTTI

Abstract— Driven by the recent enhancements provided by Automatic Dependent Surveillance-Broadcast (ADS-B) and the latest developments in 5th Generation (5G) networks supported by Unmanned Air Vehicles (UAVs), this paper describes the design of an “all-in-one” SMA coaxial fed compact blade antenna with dual frequency characteristics for broadband applications on board of UAVs. A single antenna element is designed using CST Microwave Studio software which shows a dual frequency broadband characteristic, when compared to traditional blade antennas, covering the 1.030 – 1.090 GHz and the 3.4 – 3.8 GHz ranges thanks to an oblique side and a ‘C’ shaped cavity within the radiation element. The designed antenna is simulated on an ideal ground plane first and then extended to a bent ground plane. The results are compared and discussed in terms of return loss, bandwidth, gain and radiation pattern. These results show a lightweight antenna with a low profile and a simple structure that can find numerous applications in various airborne wideband communication systems, suiting future UAV-based networks for 5G and beyond while being perfectly compliant with the ongoing ADS-B based Detect-And-Avoid (DAA) technologies for integration of UAVs in Unmanned Aerial Traffic Management (UTM).

I. INTRODUCTION

In recent years, systems and networks based on Unmanned Air Vehicle (UAV), also known as drones, are considered for various applications ranging from military and homeland security operations to entertainment, logistics and telecommunications [1–4]. Although originally conceived only for military purposes, nowadays drones have seen rapid growth and finally made a break to consumer electronics, becoming more and more popular, frequently and more widely used. As of today, we can say that drones have found a widespread use for civilian applications, especially in the form of small quadcopters and octocopters, and for a wide range of functions, owing their success to their flexibility and potential cost efficiency in comparison with conventional aircrafts or ground-based infrastructures. UAV has gained an immense popularity also among amateurs and academic researchers as suitable enablers for many emerging technologies, trials and applications, a trend likely to continue in the next future. The estimated expansion of UAV operations worldwide has motivated the urgent examination

into how these aircraft will “see and be seen” by other aircraft operating inside their own national airspace, especially towards those operations that are going to drive a large increase in air traffic volume at low altitudes. In this regard drone technologies are evolving each year, and much of the effort to safely integrate manned and unmanned aircraft in the same airspace focuses on Detect-And-Avoid (DAA) technology: drones will need to be able to avoid colliding with other aircraft, and that needs to be as automated as possible. From the ATC perspective, UAVs going into integrated airspace become a great concern to flight safety at worldwide level [5].

Among the different DAA proposals, the most promising one relies on a datalink that is already compatible with aviation, like the Automatic Dependent Surveillance-Broadcast (ADS-B) service. Since the early 2000s, ADS-B emerged as a cost-effective air navigation surveillance technology with potential room towards many and different innovative applications. Driven by the need to implement more accurate way of tracking and surveilling aircraft, ADS-B uses the Global Navigation Satellite System (GNSS) and radio signals to identify aircraft locations and to share that data in real time (Figure 1) in short intervals by means of a reserved data link in the 1090 MHz radio frequency spectrum. Conceptually, if all aircraft in the airspace used ADS-B for aircraft identification and surveillance, then conflict avoidance could be greatly facilitated.

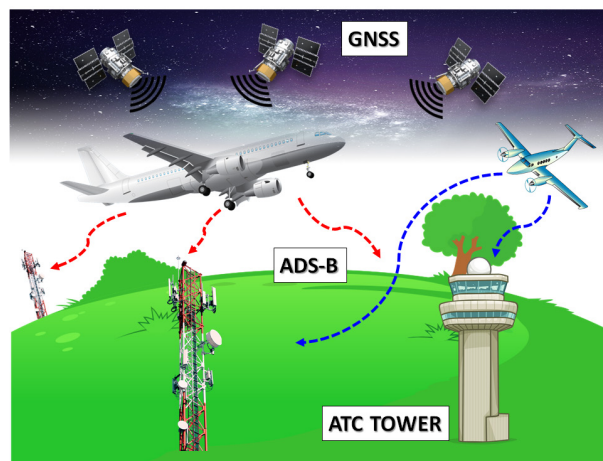

Figure 1. General ADS-B system layout, including aircraft transmitting ADS-B data to the ground thanks to their position calculated via GNSS

* This work was supported in part by NVIDIA Corporation with the donation of the Titan Xp GPU card used for this research activity.

M.J. Arpaio, F. Fuschini and D. Masotti are with the Department of Electrical, Electronic and Information Engineering (DEI) “G. Marconi”, Alma Mater Studiorum University of Bologna, BO - 40136 (ITALY) (e-mail: {maximilian.arpaio, franco.fuschini, diego.masotti}@unibo.it).

This technology has been widely used in commercial aviation for years and ADS-B has been already proven to be effective and efficient in aviation surveillance. Last year there has been a lot of movement in leveraging ADS-B as a key DAA solution in reducing risk and improving situational awareness for integration into existing Air Traffic Control (ATC) and upcoming Unmanned Aerial Traffic Management (UTM).

Considering the actual purpose for which UAVs are being used and the possible benefits for the next generation networks, Unmanned Aerial Base Stations (UABSs), i.e. base stations carried by UAVs, is one of the most promising means to offer coverage and capacity in 5G applications to those users that are not being served by terrestrial base stations, with a special focus on the extension of coverage and capacity of mobile radio networks [6][7]. During a natural disaster, local cell phone towers may lose their functionality, and this leads to the loss of communication in the area. Once set up, the UAVs can act as mobile base stations and start routing traffic to and from the cell tower (backbone) while serving users at ground level with next generation services like 5G (Figure 2). Similar techniques can be used in remote as well as in urban areas that either lack cellular coverage or need to increase their current capacity due to congested networks (and unsatisfied users) [8].

To facilitate this transition, the purpose of this work is thus to introduce the design of a broadband antenna with suitable relative bandwidth that can be used for UAV applications over 5G networks [9] while contemporary enabling DAA over ADS-B link. Specifically, this paper focuses on designing and fitting a single antenna element, which - as far as the authors are concerned - has never been described before although it clearly leads in the end to a versatile “all-in-one” radiating solution, suitable to be hosted on a drone with little compromises. The proposed antenna is centred both at 1.09 GHz and at 3.5 GHz, which emphasises its use in the mid-end of the allocated 5G spectrum (S-band) and it shows full compliancy to the International Civil Aviation Organization (ICAO) specs for ADS-B (L-band) [10] combining in one shot the benefits of the two bands.

A brief introduction is given in Section I, together with a short description of the ADS-B link technology and UABs philosophy for 5G networks and beyond. Section II describes the antenna design phase, showing the way the ADS-B and 5G bands can co-exist. Section III deals with the effect of a curvature radius on the ideal ground plane, simulating the effect of a real fuselage body. Section IV draws the main conclusions.

II. ANTENNA DESIGN AND RESULTS

Airborne communication systems require broadband antennas with light weight and aerodynamic shape to decrease the wind resistance



Figure 2. Example of an Aerial Base Station scenario for 5G services. The use of UABSs might be an efficient complement to traditional Terrestrial Base Stations (TBSs) or might even substitute TBSs in emergencies.

The antennas used in UAV are not different and they should be low profile, compact and most of the time directional, although omnidirectional features might become at hand in case of specific situations. Blade antennas are classified as planar monopole resonators and as such, the low wind resistance, aerodynamic features, light weight, simplicity of fabrication, and reasonable bandwidth make them a preferred solution. The use of antennas embedded within the UAV has several advantages such as reducing drag, enhancing the aerodynamic profile of the UAV and boosting the communication link performance with a directive pattern, all this while minimising the hindrance with regard to other parts of the fuselage. Nevertheless, sometimes it is not possible to embed antennas and thus blade antennas can be an excellent alternative.

However, the design of standard blade antennas cannot meet the requirements of modern networks and thus specific and innovative designs must be investigated. These requirements – together with the increase in data rates and a trend of miniature electronic circuits for wireless digital applications - raise numerous design challenges which aim to achieve a reasonable trade-off between technological design issues and commercial criteria at microwave as well as at millimetre wave bands.

In this section, a blade antenna with an oblique side, a ‘C’ shaped cavity, and SMA connector is introduced. This oblique side on the blade allows the antenna to achieve wider impedance bandwidth in comparison to a straight blade antenna, with no oblique edge [11]. Due to constraints on the total height of the antenna in airborne applications, the height of the blade is limited by design to less than 68 mm ($\lambda/4$ at 1.1 GHz). The ‘C’ shaped cavity – on the contrary – adds another resonating frequency to the antenna [12][13] at around 3.5 GHz. The resonating cavity has a length of less than 22 mm ($\lambda/4$ at 3.5 GHz). Of course the antenna can handle signals in the two bands simultaneously, although it

will be left to the duplexing circuitry at the front-end to distribute and process them separately.

There are few important steps in designing a blade antenna for airborne applications, among which the choice of the right material, the size of the blade and the distance from the ground plane, play an important and interconnected role. A thin, low-weight sheet of aluminium was used to achieve a wide bandwidth and good radiation efficiency. Perfect Electric Conductor (PEC) was first chosen for simulation purposes, and then the design criteria moved to aluminium for its softer mechanical properties and its common availability on the market for fabrication. To overcome the intrinsic narrowband aspect, the design was based first on an oblique side of the antenna and then on a ‘C’ shaped cavity, whose final slant angle, sizes, positions, and lengths were chosen via different simulation runs, to optimise both the gain and the required bandwidth.

The antenna design starts from the lowest frequency band, since its wavelength λ drives the final size and volume of the antenna, which in this case is centred at 1.09 GHz, according to ICAO specs. The highest frequency band on the contrary does not account for the size of the antenna and most of the effects can be fitted within the same ‘C’ shaped cavity.

Different antenna theory equations – as well as latest developments on the subject - were evaluated and used to calculate the default antenna dimensions on paper. The antenna model was then created in CST Microwave Studio suite (Figure 3) and simulated over a nearly infinite ground plane. A resonant cavity – also called slot – was introduced in the middle of the blade antenna to deal with the S-Band portion allocated to 5G. Slots can easily be concealed inside of metallic objects or they can also be manufactured to conform to the surface on which they are carved, giving in return good performances in terms of bandwidth and gain, while being easy to manufacture.

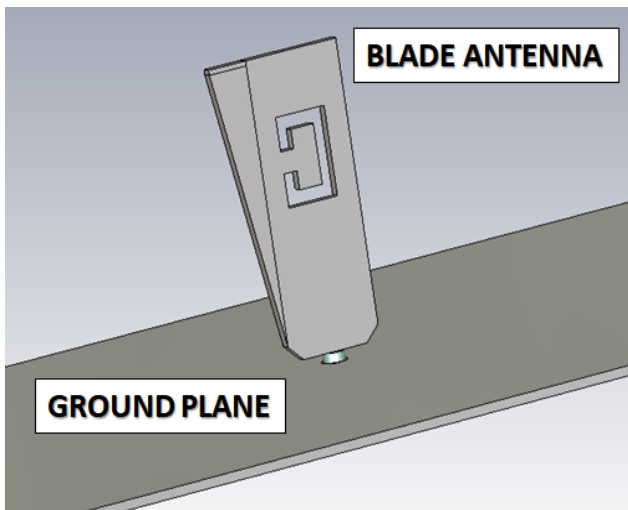

Figure 3. Perspective view of the final antenna, dual band layout

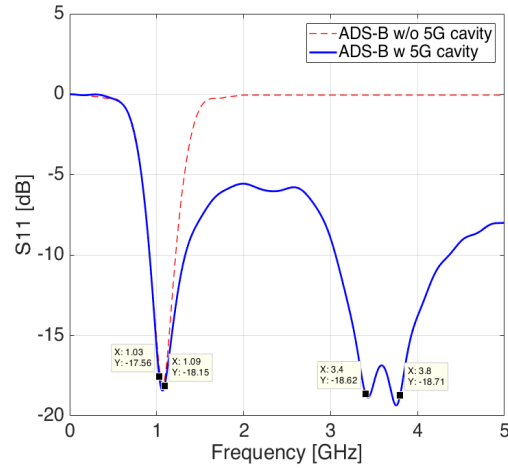
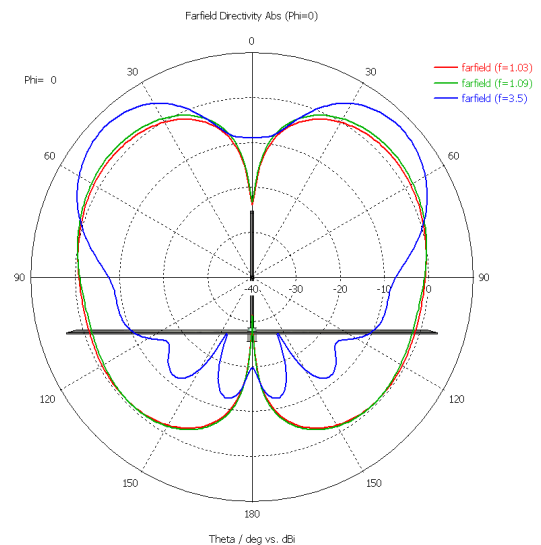

Figure 4. S_{11} of simulated ADS-B and 5G antenna, including 1.03-1.09 GHz and 3.4-3.8 GHz markers. This is compared to a simple ADS-B antenna with no 5G cavity slot (red dashed line).

Following a new optimisation phase that revised the initial design to account for different mechanical parameters and manufacturing constraints, the 50-Ohm normalised reflection coefficient (S_{11}) shows a blue line with good resonance at 1.090 GHz and at 3.5 GHz.

It should also be noted from Figure 4 that resonance at 1.090 GHz frequency and at the S-band for 5G applications is fully covered with average values below -17 dB. It should be also noted that 1.030 GHz frequency is covered too, in case of possible implementations of interrogations for Mode S, Mode A/C, Traffic Alert and Collision Avoidance System (TCAS) or even Airborne Collision Avoidance System (ACAS) [14] on board of UAVs. The same figure shows the intrinsic narrowband features of the ADS-B blade antennas with a red dashed line, nevertheless here slightly enhanced due to the oblique side.



(a) XZ, E-plane

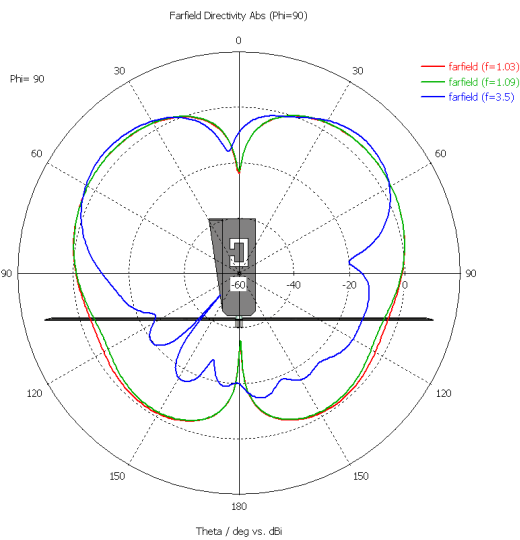

(b) YZ, E-plane

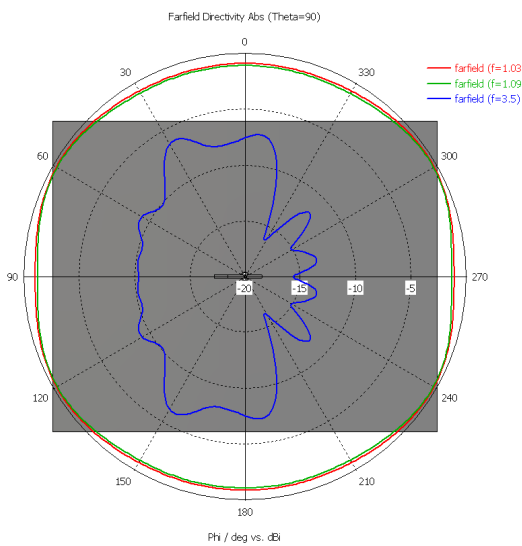

(c) XY, H-plane

Figure 5. Radiation Diagrams on (a) XZ, (b) YZ and (c) XY planes at 1.03, 1.09 and 3.5 GHz

Radiation Diagrams on different E-H planes are in line with expectations. The resonating frequency band at 3.5GHz is more influenced by the ground plane, as it can be expected, than its counterpart at 1.09 GHz and this can be seen from the following cuts at different planes in Figure 5.

The main drawback in this solution is a loss in omnidirectionality in the H plane for 5G communications, while directivity on the E plane improves. Consequently, antenna gain is around 7 dBi at 3.5 GHz while it stays untouched around 4dBi at 1.09 GHz, as it can be seen from Figure 6.

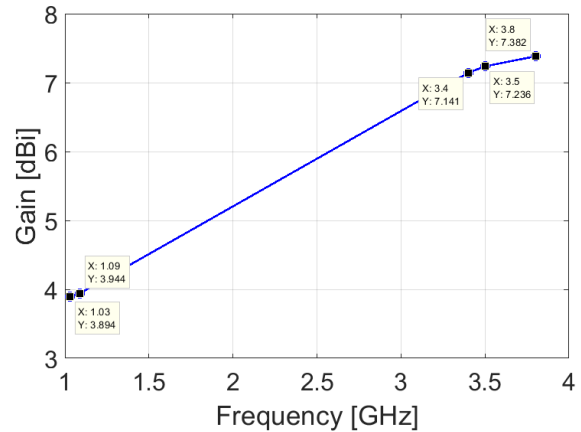

Figure 6. Gain trend values at ADS-B L-Band and 5G S-Band

The following Figure 7 summarises the final mechanical dimensions of the antenna layout, including details on the oblique side and the ‘C’ shaped slot.

III. PERFORMANCES UNDER DIFFERENT FUSELAGE CURVATURES

The most difficult challenge is to determine how the antenna behaves when placed on the body of a generic aircraft. This is particularly true in case of blade antennas, for which the ground plane plays an important role.

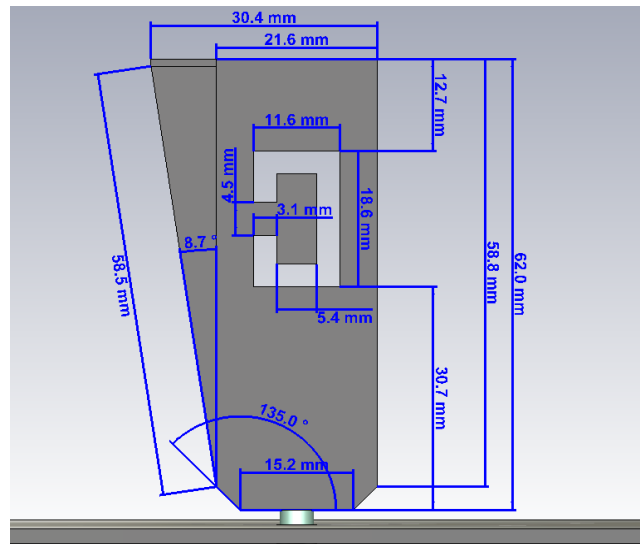

Figure 7. Side view on YZ plane of the antenna with final dimensions (in mm)

On one hand, the fuselage easily replaces - and behaves as a reasonable - ground plane; on the other hand, the fuselage is not a perfectly flat surface of infinite length, but it is bent and thus it can affect the performances of the antenna.

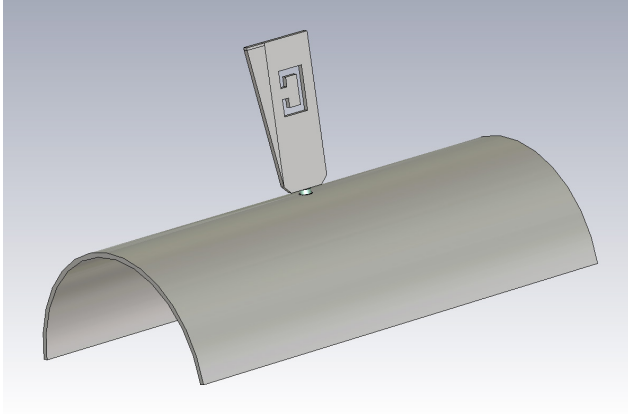

Figure 8. Blade antenna on a bent ground plane ($R=50$ mm, example)

Performances in terms of antenna matching to 50 Ohm (S_{11} parameter) have been investigated under the ideal case of a set of three uniform fuselage curvatures of radius R , in the X-axis direction (Figure 8). The curvature radius R was chosen following three possible bending ray values $R= 50$, 275 and 500 mm.

The following picture summarises the outcomes of the simulation runs, under different radius sweeps in the ‘X’ direction (Figure 9). Changes in the S_{11} plot are seen in the 1.090 GHz frequency band, with general improvements in the matching. Conversely, there is a minor effect – if no effect at all – in the S-band at 3.5GHz (Figure 9). Although not reported within this paper, it was seen that for low values of R the radiation diagram in the XY plane loses its omnidirectional properties at 1.09 GHz – with a light null in the direction of the ‘X’ axis - while it shows far less changes at 3.5GHz, for any value of the curvature radius R .

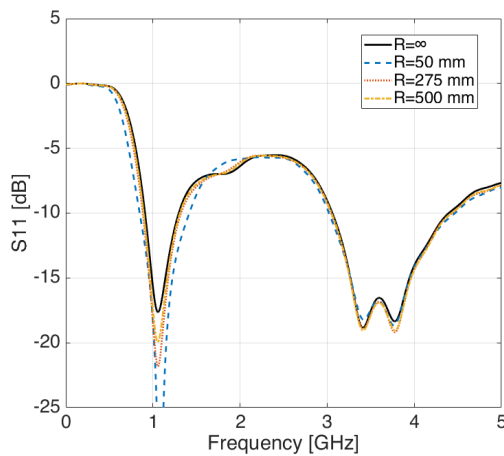

Figure 9. S_{11} of simulated ADS-B and 5G antenna at different fuselage curvatures along X axis

Meaningless variations of the same radiation diagram are observed on the XZ and YZ planes for both frequencies, meaning this radiation plane has less inference with regards to the bending radius.

IV. CONCLUSION

The next generation of UAVs is expected to be used for a wide spectrum of civilian and public domain applications. In this regard, the design of antennas granting broadband UAV applications over 5G networks brings definitely new challenges to designers, especially when they have to deal also with original solutions that can pave the way towards full integration of UAVs with manned aviation and into the respective national airspace.

To support this evolution, the blade antenna in this paper at 1.09 GHz and 3.5 GHz for UAV applications, shows a novel/cutting edge idea with a system application potential, however, not yet fully developed and tested. The single band antenna performances were compared to those of a dual band antenna, which performed better in terms of gain and impedance matching, thus broadening the fields of use. The proposed antenna is very simple to manufacture, and it uses low-cost materials, which makes it easy to fabricate. Matching characteristics of the blade antenna are evaluated under different bending conditions for UAV installation on a fuselage. Results show matching performance acceptably robust in most cases, although a little shift in the resonant frequency is seen. Overall, the performance of the antenna meets the desired in-field requirement in terms of return loss, gain and - especially – mechanical dimensions and weight.

Further investigations in this research project aim to compare the simulated results with the actual measurements on a prototype and then to move forward the investigations to higher 5G bands, i.e. 26 GHz or even 70 GHz frequency ranges. Lastly, it would be wise to evaluate the optimum antenna placement on a real and complete UAV body model so as to optimise propagation as well as the impact of this antenna on the control performances of the UAV.

ACKNOWLEDGMENT

The authors wish to show appreciation to Prof. Marco Lovera and his research group from Politecnico di Milano, Department of Aeronautical Engineering, for the given insights on UAV models and characteristics.

REFERENCES

- [1] M. Asadpour, B. Van den Bergh, D. Giustiniano, K. A. Hummel, S. Pollin, and B. Plattner, “Micro aerial vehicle networks: An experimental analysis of challenges and opportunities,” *IEEE Communications Magazine*, vol. 52, no. 7, pp. 141–149, 2014.
- [2] K. Namuduri, S. Chaumette, J. H. Kim, and J. P. Sterbenz, *UAV Networks and Communications*. Cambridge University Press, 2017.
- [3] K. P. Valavanis and G. J. Vachtsevanos, *Handbook of unmanned aerial vehicles*. Springer, 2015.

- [4] M. M. Azari, F. Rosas, K.-C. Chen, and S. Pollin, "Ultra reliable uav communication using altitude and cooperation diversity," *IEEE Transactions on Communications*, vol. 66, no. 1, pp. 330–344, 2018.
- [5] Demonstrations Evaluate UAV Collision-Avoidance Technology, National Aeronautics and Space Administration News Release, <http://www.nasa.gov/centers/dryden/news/NewsReleases/2003/03-20.html>, April 2003
- [6] M. Mozaffari, W. Saad, M. Bennis, Y.-H. Nam, and M. Debbah, "A tutorial on uavs for wireless networks: Applications, challenges, and open problems," arXiv preprint arXiv:1803.00680, 2018.
- [7] M. M. Azari, F. Rosas, and S. Pollin, "Cellular connectivity for UAVs: Network modeling, performance analysis and design guidelines," to appear in *IEEE Trans. on Wireless Commun.* Available as arXiv:1804.08121, Apr. 2018.
- [8] Y. Zeng, Q. Wu, and R. Zhang, "Accessing from the sky: A tutorial on UAV communications for 5G and beyond," available as arXiv:1903.05289, Mar. 2019.
- [9] Hongliang Zhang, Lingyang Song, Zhu Han "Unmanned Aerial Vehicle Applications Over Cellular Networks for 5G and Beyond", *Wireless Networks series*, Springer International Publishing 2020.
- [10] ADS-B implementation and operations guidance document, <https://www.icao.int/APAC/Documents/edocs/AIGD%20Edition%2011.pdf>
- [11] B. A. Arand, R. Shamsaee and B. Yektakhah, "Design and fabrication of a broadband blade monopole antenna operating in 30 MHz–600 MHz frequency band," 2013 21st Iranian Conference on Electrical Engineering (ICEE), Mashhad, Iran, 2013, pp. 1-3, doi: 10.1109/IranianCEE.2013.6599878.
- [12] M. Nosrati, A. Jafarholi, R. Pazoki and N. Tavassolian, "Broadband Slotted Blade Dipole Antenna for Airborne UAV Applications," in *IEEE Transactions on Antennas and Propagation*, vol. 66, no. 8, pp. 3857-3864, Aug. 2018, doi: 10.1109/TAP.2018.2835524.
- [13] A. Patrovsky and R. Sekora, "Structural integration of a thin conformal annular slot antenna for UAV applications," 2010 Loughborough Antennas & Propagation Conference, Loughborough, UK, 2010, pp. 229-232, doi: 10.1109/LAPC.2010.5666169.
- [14] EUROCONTROL Guidelines on the Assessment of Ground-based Surveillance Interrogations <https://www.eurocontrol.int/sites/default/files/2020-09/eurocontrol-guidelines-assessment-ground-based-surveillance-interrogations-ed-2-0.pdf>