



ALMA MATER STUDIORUM
UNIVERSITÀ DI BOLOGNA

ARCHIVIO ISTITUZIONALE
DELLA RICERCA

Alma Mater Studiorum Università di Bologna Archivio istituzionale della ricerca

Energizing 5G: near- and far-field wireless energy and data transfer as an enabling technology for the 5G IoT

This is the final peer-reviewed author's accepted manuscript (postprint) of the following publication:

Published Version:

Costanzo, A., Masotti, D. (2017). Energizing 5G: near- and far-field wireless energy and data transfer as an enabling technology for the 5G IoT. IEEE MICROWAVE MAGAZINE, 18(3), 125-136 [10.1109/MMM.2017.2664001].

Availability:

This version is available at: <https://hdl.handle.net/11585/585292> since: 2017-09-19

Published:

DOI: <http://doi.org/10.1109/MMM.2017.2664001>

Terms of use:

Some rights reserved. The terms and conditions for the reuse of this version of the manuscript are specified in the publishing policy. For all terms of use and more information see the publisher's website.

This item was downloaded from IRIS Università di Bologna (<https://cris.unibo.it/>).
When citing, please refer to the published version.

(Article begins on next page)

This is the final peer-reviewed accepted manuscript of:

A. Costanzo and D. Masotti, "Energizing 5G: Near- and Far-Field Wireless Energy and Data Transfer as an Enabling Technology for the 5G IoT" in IEEE Microwave Magazine, vol. 18, no. 3, pp. 125-136, May 2017

The final published version is available online at:

<https://doi.org/10.1109/MMM.2017.2664001>

Rights / License:

The terms and conditions for the reuse of this version of the manuscript are specified in the publishing policy. For all terms of use and more information see the publisher's website.

This item was downloaded from IRIS Università di Bologna (<https://cris.unibo.it/>)

When citing, please refer to the published version.

Energizing 5G

Alessandra Costanzo and Diego Masotti

xxxxxxx

We are surrounded in our daily lives by a multitude of small, relatively inexpensive computing devices, many equipped with communication and sensing features. From these has evolved the concept of “pervasive intelligence” [1], [2], a basis from we can envision our future world as an Internet of Things/Internet of Everything (IoT/IoE), in terms of both a consumer IoT/IoE (interconnected devices within an individual’s environment) and the Industrial IoT (interconnectedness to improve business-to-business services, mainly through machine-to-machine interactions) [3].

Decades of research have produced a plethora of devices for a variety of application domains, devices

that do not always share common standards and communication requirements. It is envisioned that the advent of fifth-generation (5G) communication networks will bring together all these requirements by integrating multiple heterogeneous access technologies. Moreover, 5G’s goals of increased data rates, reduced end-to-end latency, and improved coverage [4] will support an exponentially greater number devices with reduced cost per information transfer, thus making our vision for the IoT/IoE feasible in practice. Achieving these goals, will force future 5G networks to rely on a multitier architecture starting from the macrocell level and moving up to device-to-device (D2D) micronetworks [5]. In this article, we focus on

Alessandra Costanzo (alessandra.costanzo@unibo.it) and Diego Masotti (diego.masotti@unibo.it) are with the Department of Electrical, Electronic, and Information Engineering “Guglielmo Marconi,” University of Bologna, Italy.

Digital Object Identifier 10.1109/MMM.2017.2664001

Date of publication: xxxxxx

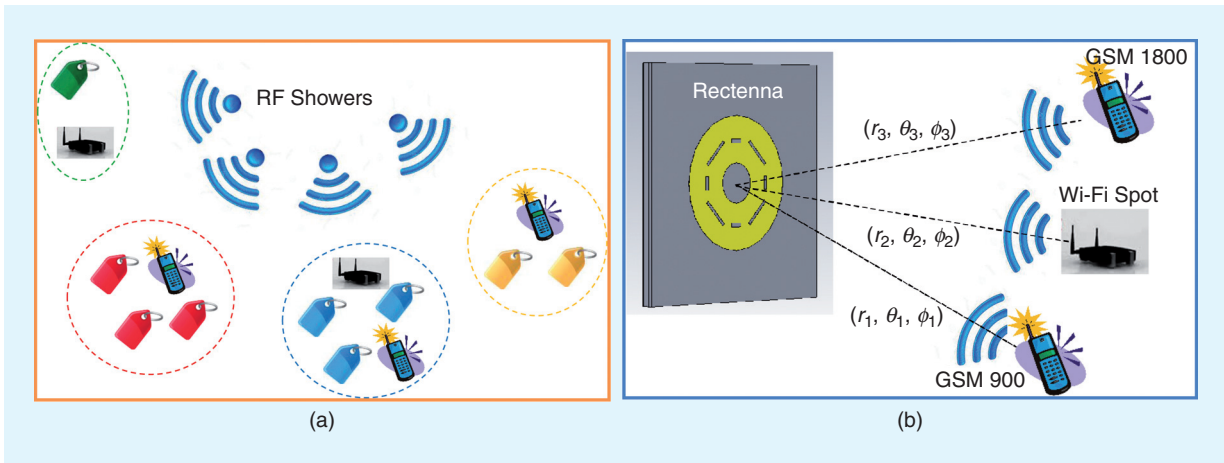

Figure 1. Two scenarios for implementing energy autonomy for RF tags with (a) dedicated RF sources (or showers) and (b) environmental multifrequency sources [11]. GSM: Global System for Mobile Communications.

the latter application field, where the availability of energy-aware devices is desirable.

Wireless-Powered Communication Networks

With the scenario of a 5G IoT in mind, many researchers are currently focused on the challenging task of recharging ubiquitous devices and machines wirelessly to allow truly perpetual wireless-powered communication (WPC) [6]. This requires either some kind of direct battery-recharging operation as with a mobile phone [7] (which is more feasible from a current technological standpoint) or a more futuristic, “green,” batteryless architecture for low-profile wireless devices (as described in [8] for wireless sensor applications).

From this perspective, a distinction must be made in terms of energy requirements. Normally “off” devices need to be interrogated only a few times a day to wirelessly provide information monitoring of their activities (also known as “smart dust”) [9]; due to their very low duty cycle, devices like these have ultralow power needs [10]. On the other hand are devices (typically machines) that require frequent or even continuous support at medium to high energy levels.

Depending on these two classifications, the energy sources exploited in the charging operation vary: for ultralow power applications, the sources are typically environmental and/or unintentional, while intentional sources are adopted when larger amounts of power are involved [11]. WPC networks (WPCNs) can thus be created to efficiently energize several communication devices [6].

In some cases, tradeoff applications are foreseen as well. Intentional wireless sources (called “energy showers”) periodically provide the requested low amount of energy to batteryless tags for real-time locating or tracking applications [12]. In all the envisioned scenarios, the receiving (Rx) device needs to be equipped with a rectifying antenna (or rectenna), i.e., a structure able to receive the incoming wireless signal and to convert it from the higher frequency used in the transmission to direct current (dc). Figure 1 shows two possible scenarios: an intentional shower, broadcasting energy to devices randomly distributed in the environment [Figure 1(a)], and a multiband rectenna able to recover energy from the different wireless standards commonly present in any human-created environment [Figure 1(b)] [11].

Hence, the energy autonomy of IoT/IoE actors in the context 5G is a topic of significant current concern, and interesting investigations have been carried out in recent literature. In [13], for example, the exploitation of heterogeneous, multiradio small cells is presented

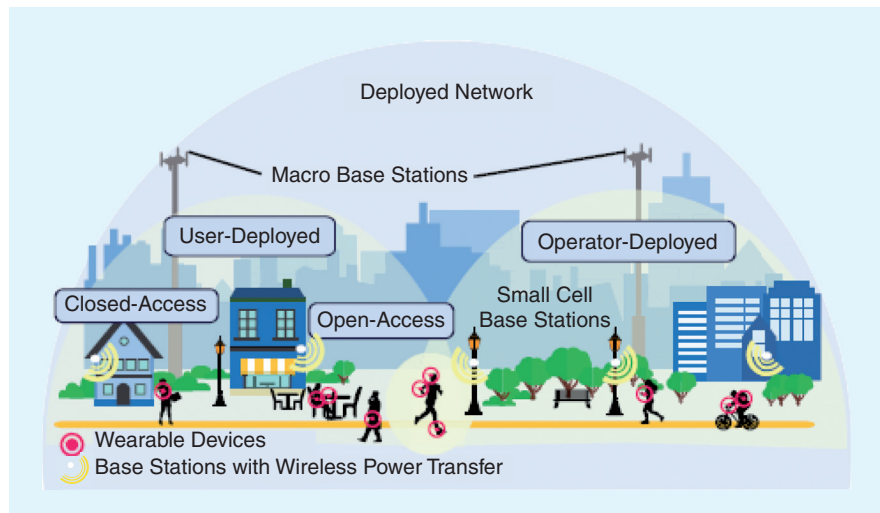

Figure 2. A 5G network scenario for wireless charging [13].

TABLE 1. A comparison of NF-WPT and FF-WPT.

	NF-WPT		FF-WPT
	Resonant	Nonresonant	
Transmission mechanism	Coupling, no wave propagation	Coupling, no wave propagation	Wave propagation
Interacting device	Coils/electrodes	Coils/electrodes	Antennas
Tx–Rx antenna interaction	Strong interaction	Medium interaction	No interaction
Operating frequency	LF, HF	LF, HF	Microwave, millimeter-wave
Power level	Medium (mW–W), High (kW)	Medium (mW–W), High (kW)	Ultralow (μ W–mW) High (MW)
Efficiency	High (70–90%)	Medium (30–60%)	Low (10–50%)
Commercial applications	Yes	Yes	No

as an opportunity to realize very efficient wireless energy transfer to wearable devices, as depicted in Figure 2.

The authors of [14] provide very useful considerations concerning the practical limits of WPC, such as the limit in intentional sources' directivity, that suggest exploiting massive arrays at high frequencies (> 30 GHz); otherwise, the dimension of the radiating structure becomes incompatible with the application. The authors of [14] also suggest the main directions of research in wireless power transfer (WPT)/wireless energy transfer (WET): for example, the use of backscatter antennas to provide a solution for energizing low-complexity passive devices, such as in RF identification (RFID) applications, as well as the new trend toward suitable power waveform optimization that can lead to improvements in the transfer mechanism (this is also demonstrated in [15] and [16]). In addition, very promising energy savings are described in [17], when location-aware devices cooperate in D2D scenarios.

Our main purpose here is to delineate the design steps required to accurately optimize the key figures of merit involved in the end-to-end wireless link within a 5G IoT/IoE scenario. Such estimation is, in fact, mandatory for predicting the feasibility of the wireless transmission of power [18], especially in those applications where the medium between the energy source and the wirelessly powered device/machine requires a complex radio channel with random variations, such as irregular civil [19] and industrial sites or body tissue layers. This design approach is presented through the discussion of new and promising solutions available in the literature, devoted to both far-field and near-field wireless powering.

Wireless Powering Figures of Merit

Wireless delivery of power can adopt two radically different mechanisms:

- exploiting far-field RF sources for so-called far-field WPT (FF-WPT), where the involved frequencies are in the microwave (300 MHz–30 GHz)

[20], [21] or millimeter-wave (30–300 GHz) [22], [23] ranges

- exploiting the near (or reactive) field provided by closely located sources in the low-frequency (LF; 30–300 kHz) [24] or high-frequency (HF; 3–30 MHz) [25] ranges for so-called near-field WPT (NF-WPT).

The NF-WPT approach can be further split into two alternatives:

- resonant-coupling power transfer, which exploits the resonance between the involved devices [26] for known and receiver-reciprocal positions
- nonresonant power transfer [27], which is more suitable when transmitter and receiver misalignments are not predictable, such as in RFID applications or for electric vehicle charging.

These alternative approaches rely on completely different transfer mechanisms; for this reason, they are almost entirely complementary, as summarized in Table 1. In the case of FF-WPT, the radiation of an electromagnetic (EM) wave occurs through the exploitation of a radiating structure (antenna), and the corresponding radiated RF power can be intentional (in the case of FF-WPT) or unintentional/environmental [in the case of RF energy harvesting (EH) applications] [28]. However, when far-field sources are involved, it is worth noting that no direct interactions between the transmitting (Tx) and Rx antennas take place because the Tx antenna sends the same amount of power whether or not a receiver is present.

From this point of view, the situation is completely different in the case of nonradiative NF-WPT, where inductive links (exploiting magnetic fields) or capacitive links (exploiting electric fields) are established between colocated coils/wires or electrodes/metallic plates, respectively. Being in the reactive field region, the power delivered to the field by the Tx coil/plate returns back in cases where the Rx coil/plate is absent and thus depends on the Rx coil/plate's position. This dependency is extremely strong in the case of resonant NF-WPT, where a narrow-band resonance is established between the transmitter and receiver [26].

Consequently, several solutions are proposed to minimize/cancel this dependency [26], [29], [30]. The reciprocal position (including link coverage) is less critical in the nonresonant NF-WPT transfer mechanism. Here, the (typically) coils are different in size (the transmitter is larger), and, being far from resonance, the Tx/Rx input impedances are almost constant by varying (within certain limits) their reciprocal position; thus, satisfying matching conditions can be easily guaranteed.

With regard to commercial research applications, the far-field approach is mainly deployed when low (FF-WPT) or ultralow (EH) power applications are envisioned. Only in space and military targets, where cost is not an issue, do high-power FF-WPT activities exist [31], [32]. NF-WPT has, up to now, more commercial applications than FF-WPT. Nonresonant NF-WPT has been widely applied for many years in HF RFID, where medium to high power levels are involved; resonant NF-WPT can also manage high power levels, mainly due to a more efficient link (thanks to the resonance) with reduced costs as well as less stringent safety exposure limits at lower frequencies (< 100 MHz).

The classification described previously is expanded by a more recent wireless transfer mechanism resorting to the middle field provided by microwave sources. This technique is mainly seen as an alternative to NF-WPT for wirelessly powering implanted devices [33]. Unlike conventional near-field approaches, mid-field WPT (MF-WPT) relies on an actual field propagation and does not suffer from rapid decay with distance [as $(\text{distance})^{-3}$], which is the case of the far field. Here, environmental/tissue losses play a fundamental role; for this reason, intensive investigations on the optimal frequency for maximizing the power transfer have been carried out, providing the interesting result that the optimal frequency is in the gigahertz range for a millimeter-sized Tx antenna and shifts to the sub-gigahertz range for a centimeter-sized Tx antenna [34].

Based on all this, it become clear that defining figures of merit capable of summarizing wireless link quality is essential. Despite of the significant differences among these approaches, the wireless link building blocks can, in all cases, be depicted as in Figure 3: planar coils and planar microstrip antennas are representative of the two transmission mechanisms, but capacitively coupled links or other antenna types can be adopted equivalently.

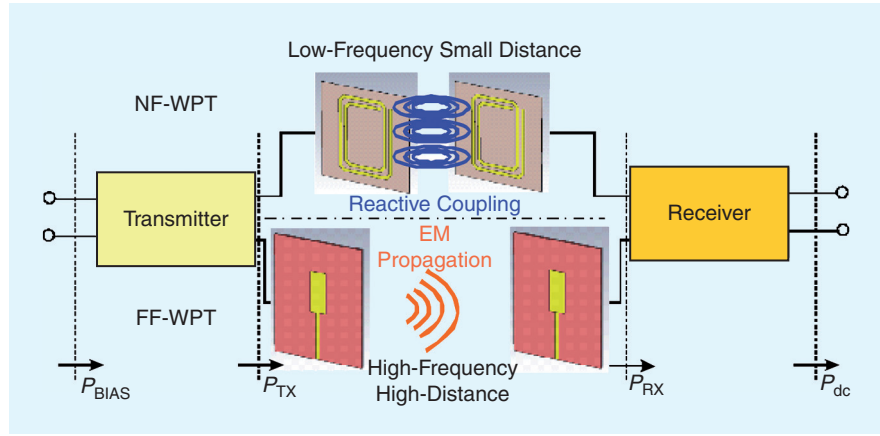

Figure 3. The building blocks of a wireless link involving either near or far fields.

As a consequence, in terms of efficiencies, all wireless powering mechanisms share the main figures of merit as demonstrated by (1):

$$\eta_{\text{LINK}} = \eta_{\text{DC-TF}} \cdot \eta_{\text{TF-TF}} \cdot \eta_{\text{TF-DC}} = \frac{P_{\text{TX}}}{P_{\text{BIAS}}} \cdot \frac{P_{\text{RX}}}{P_{\text{TX}}} \cdot \frac{P_{\text{DC}}}{P_{\text{RX}}} \quad (1)$$

In fact, η_{LINK} represents the efficiency of the entire wireless power system from the transmitter dc bias to the receiver dc output. The first term, $\eta_{\text{DC-TF}}$, is the ratio between the power P_{TX} at the transmission frequency used in the energy transmission (microwave or millimeter-wave for cases of the far and middle fields, and LF or HF in the case of the near field) available at the Tx antenna/coil input port and the dc power required at the transmitter side (P_{BIAS}): this contribution is mainly due to the conversion efficiency of the RF power source and of the amplifier at the transmitter side.

The second term, $\eta_{\text{TF-TF}}$, is the efficiency in the transmission frequency of the wireless path covered during the energy transfer operation (ranging from a few millimeters to a few centimeters in the case of resonant NF-WPT, a few centimeters to tens of centimeters in the cases of nonresonant NF-WPT and MF-WPT, a few meters to tens of meters in the case of low-power FF-WPT, and up to hundreds of kilometers in the case of high-power FF-WPT). It consists of the ratio between the power received by the antenna/coil at the receiver side (P_{RX}) and P_{TX} and is strongly related to the medium in between the transmitter and the receiver, as well as on the antennas'/coils' efficiencies [18], [25].

Finally, the last term, $\eta_{\text{TF-DC}}$, is the ratio between the dc power delivered to the final user (P_{DC}) and the received one (P_{RX}), i.e. the conversion efficiency of the rectifying section from the higher frequency to dc. It is typically given by the further product of two efficiencies: the RF-to-dc conversion efficiency of the sole rectifier and the dc-to-dc efficiency of the power management unit representing the actual load of the rectifying circuit, designed specifically to provide the

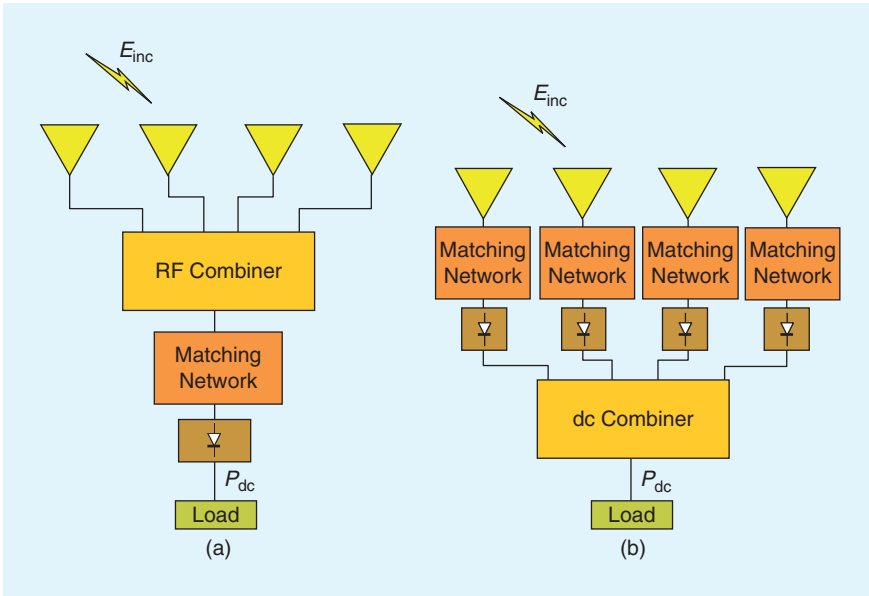

Figure 4. Rectenna architectures for (a) intentional far-field power transmission (b) RF EH purposes [39].

maximum dc output power for varying loading conditions [35], [36].

It is worth mentioning that the entire WPT system consists of a connection of nonlinear circuits; for this reason, (1) strongly depends on the involved power levels and operating frequencies and can be accurately evaluated only if all phenomena (both linear and nonlinear) are rigorously taken into consideration, thus providing a precise estimate of the powers contributing to (1). For instance, it is a demanding task to calculate P_{RX} , which makes the term η_{TF-DC} the most delicate one in (1): a rigorous circuit-equivalent model formulation for the prediction of this contribution can be derived by EM theory [18], [36].

Moreover, an additional comment on P_{TX} is worthwhile: in NF-WPT and intentional FF-WPT, P_{TX} is a known contribution, whereas it represents an

unknown in EH scenarios, where unintentional ambient sources are deployed [16]. In such cases, incoming field intensity, polarization, and direction of arrival are not a priori known, thus making the rectenna design a cumbersome task in EH applications, a task that relies on realistic estimations of the available power levels [37], [38]. To clarify this point, Figure 4 shows the standard layout of two rectennas, one for intentional FF-WPT [Figure 4(a)] and the other for EH purposes [Figure 4(b)] [39]. In the first case, an RF combination of the antennas provides an array behavior with a high gain of the Rx antenna; in the

other case, the unknown direction of arrival of the signal suggests the use of a multiple antenna configuration (the combination is made in dc) so as to have more low-gain (ideally, omnidirectional) antennas.

Simultaneous Power and Data Transfer

Simultaneous wireless information and power transfer (SWIPT) [5], [40] is currently being investigated in a wide range of different systems for both civil and industrial applications. A block schematic of an available solution [41] in an automatic machine environment is illustrated in Figure 5.

The upper part of Figure 5 shows the actuator supply where the power is modulated by the switching dc/ac converter and wirelessly delivered to the actuator (e.g., a heater) by a contactless energy transfer unit. The lower part of the figure consists of the feedback path

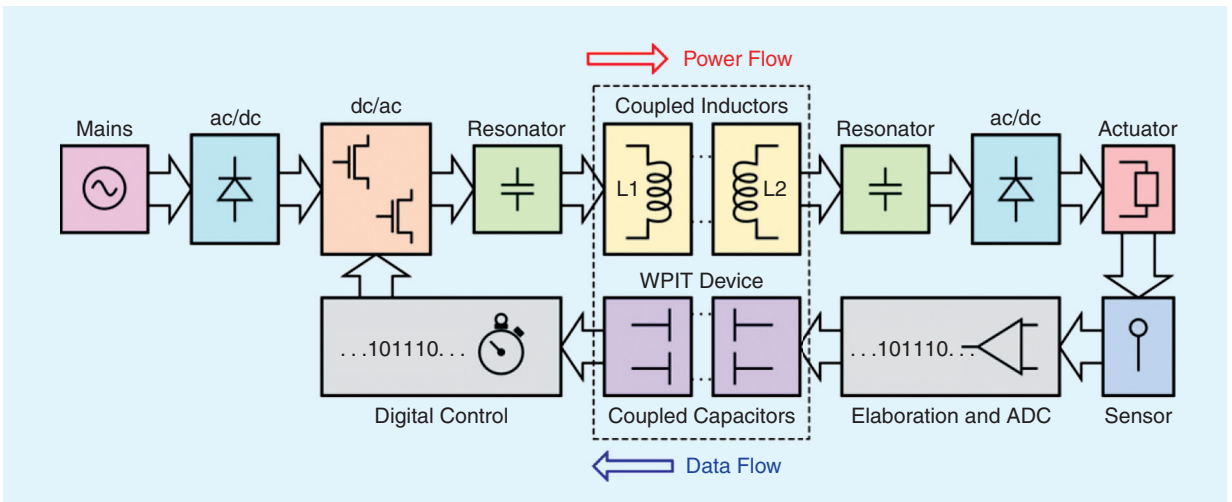

Figure 5. A block schematic of an automatic machine system with SWIPT capabilities [41]. ADC: analog-to-digital conversion.

of the sensor data: its readout is elaborated and sent back to the controller through a secondary wireless interface. The power flow that supplies the actuator shown in Figure 5 does not represent a reliable source of energy for sensing, because it is not continuous. In this case a passive sensing solution is adopted by means of a near-field RFID link that monitors the variation of a variable (for example, a resistive load representing a temperature sensor) by estimating the impedance mismatch at the input port of the link, i.e., at the reader side.

This has been referred to as *direct passive RFID sensing*. A quite accurate sensitivity is obtained by configuring the source and the link in highly mismatched conditions. In this way, by measuring the power entering the input port of the link or by sensing the voltage across its terminals, the resistive sensor state is retrieved. Then, the behavior of such quantities can be characterized, and it is possible to establish an accurate relation between the measured readout (power or voltage) and the observed variable (e.g., a resistive sensor load). The advantage of this technique is that it is completely passive and does not require any microcontroller unit circuitry to be embedded on the inaccessible remote sensing unit. Rather, the sensor readout is collected at the reader side of the data link, where the energy source is ensured by the power supply.

A block diagram of the entire sensing link is shown in Figure 6, where the resistance temperature detector (RTD) is driven by the rectified voltage and current of the RF excitation. The receiver side is optimized with the goal of providing the largest range of reflected power at its input port with respect to the interval variations of the RTD's load. The wireless link operates in the ultrahigh-frequency (UHF) band and is based on two coupled splitting resonators (SRRs), the layout of which is designed to operate as a self-resonant reactive structure [41]. The system is able to provide very accurate temperature measurement as shown in Figure 7, where the measured relationship between the temperature and dc voltage level is compared.

SWIPT for Portable Devices by Means of Dedicated or Existing Antenna Systems

The challenges for 5G cellular wireless networks lie mainly in improving overall system behavior in terms of end-to-end performance, energy consumption, and cost per information transfer [5]. In this scenario, D2D communication will play an important role, as well as any additional RF EH capability that future devices will have to share: hence, the combination of near-field or far-field power and information transfer will be essential for next-generation mobile devices, possibly achieved by deploying the majority of their components. This challenging operation can be pursued by exploiting both existing circuitry and dedicated new components: of course, the reduced space

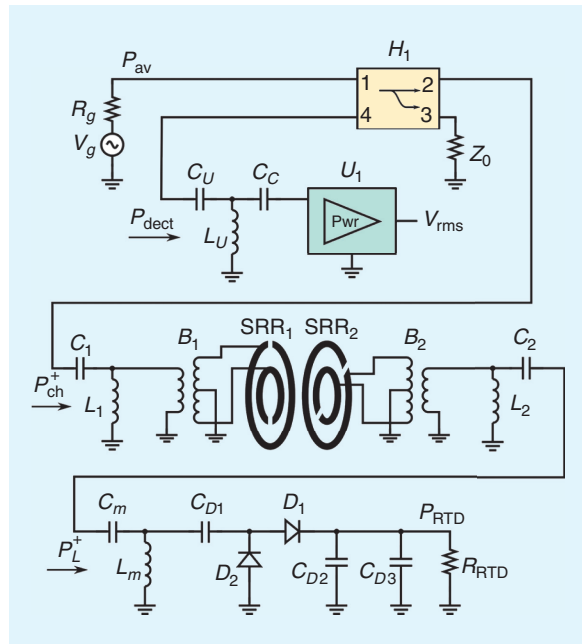

Figure 6. The circuit-equivalent schematic of an entire wireless UHF passive sensing system [41].

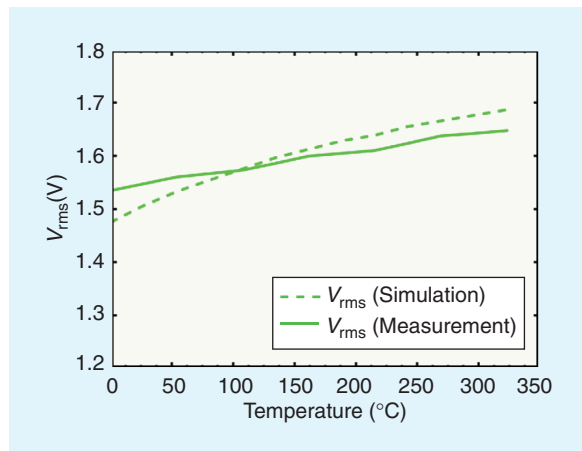

Figure 7. The measured and predicted relationship between the sensed temperature and the power detector output voltage [41].

consumption of the first means, in turn, lower transfer efficiency than the dedicated solution.

It is worth noting that, when dealing with simultaneous data and power transmission, the frequency-division approach is often adopted. This means that different frequency bands are responsible for the wireless information and energy transfer. Moreover, this is true in both NF-WPT [42] and FF-WPT [43]. One example of a dedicated link for NF-WPT is offered by Qualcomm [7]; here, a loosely coupled resonant system must be managed due to the metal body of the phone. To the authors' knowledge, this is the first example of a metal-backed mobile phone recharged by a standard AirFuel Alliance-resonance-compatible charger (although several other solutions are already commercially available,

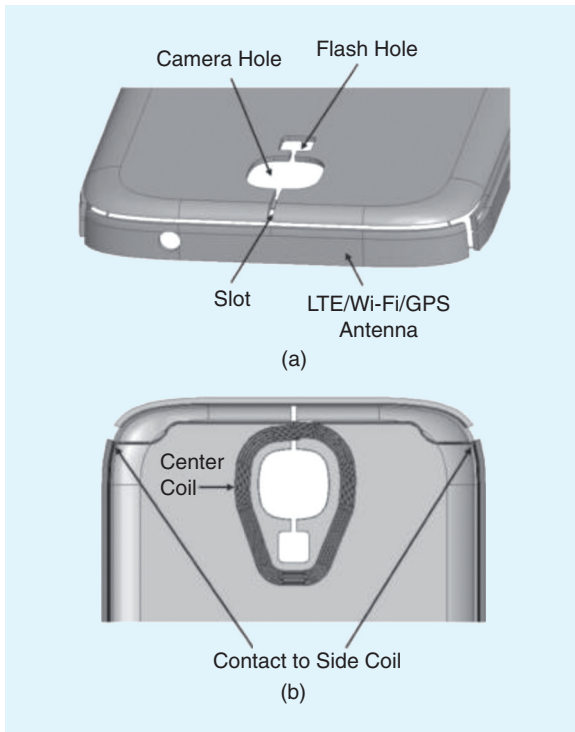

Figure 8. Details of a metal case for a mobile phone: (a) a perspective view and (b) the back view [7]. LTE: long-term evolution; GPS: global positioning system.

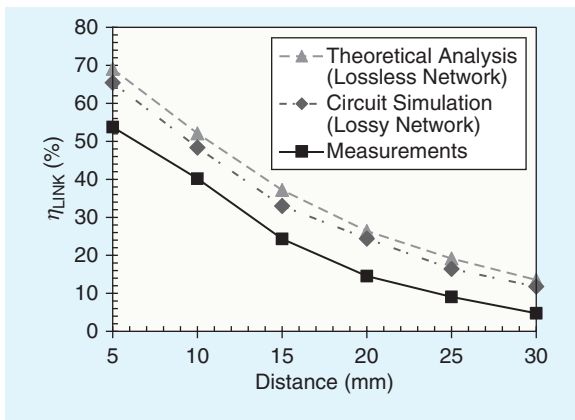

Figure 9. The predicted (both theoretical and simulated) and measured link efficiencies for variable antenna separation [45].

using an additional case for charging purposes). In this application, 6.78 MHz is the HF adopted for the transmission of power. The original idea is to exploit the eddy currents induced on the phone metallization by the Tx magnetic field: an additional slot is introduced in the metal case [as shown in Figure 8(a)], thus forcing the induced current to flow around the existing camera/flash holes, where a dedicated new coil has been positioned [Figure 8(b)]. Finally, the Rx coil is attached onto the metal case, and the phone itself is tuned with a capacitor to reach the resonance. In this way, the metal cover becomes part of the Rx resonator. This trick allows the transfer efficiency of the loosely

coupled system to be increased. Moreover, the central coil is series-connected to two additional side coils [Figure 8(b)], the purpose of which is to increase the overall inductance and thus the induced voltage in the resonator. It is worth noting, of course, that the additional circuitry in the mobile phone does not affect the multiband antenna used for communication purposes: regular phone calls have been successfully made in the presence of the wireless charging resonator [7].

Recent studies have also demonstrated the possibility of reusing existing portable device antennas, designed for multiband far-field communication, in a loosely coupled near-field link [44], [45]. In this application, the industrial, scientific, and medical 433-MHz band is devoted to the NF-WPT link, while the standard Global System for Mobile Communications frequency bands (900 and 1,800 MHz) are used in far-field communication. The choice of a quite high frequency for near-field coupling is the result of a trade-off between minimizing lumped-element values to achieve resonance (high frequency \rightarrow low inductance \rightarrow low losses) and still having an electrically small antenna, thus involving only reactive fields.

Obviously, the system is not specifically designed for WPT, and this justifies the limited maximum efficiency obtainable through exploiting the weak reactive coupling established among the thin planar antennas' metallization, as shown in Figure 9: here, the η_{TF-TF} efficiency of (1) at 433 MHz (derived from theoretical analysis, circuit simulation, and measurements) is plotted versus the distance between two facing mobile phones. Despite the nondedicated link, 40% of measured efficiency is achieved when the two devices are 1 cm apart. However, the great advantage of this new idea is to realize near-field recharging without further crowding the portable devices' circuitry; the research reported in [44] and [45] represents the proof of concept for the feasibility of this transfer of power.

One of the main challenges of this architecture involves the design of the three-port diplexer feeding each antenna, as shown in Figure 10. The frequency separation between the WPT frequency (433 MHz) and the communication frequencies (900 and 1,800 MHz) allows the exploitation of the frequency-division mechanism in the diplexer's synthesis: the lumped-element solution adopted in [44] and [45] provides high isolation (> 40 dB) between the two paths, thus guaranteeing that communication is possible while power is being transferred (and vice versa).

However, the frequency-division approach can be spectrally inefficient, even if more robust from the EM interference point of view. Alternatively, more challenging SWIPT solutions have been proposed in the far-field cases only, where the same frequency is shared in both power and data transfer. The main issue is the WPT's interference on the data transmission [6] because of the higher power level. Solutions

to this problem could be the time-division access of data and power [6]; dynamic beamforming techniques, such as the attractive time-modulation of the radiating system described in [21]; or the promising use of channel sensing proposed in [46] to adaptively modify the weights of a multisine signal on the transmitter side and so maximize the power transfer. This last solution is now at the research stage, but it is foreseen to be widely exploitable in large industrial plants with harsh EM characteristics as a way to advance the automated machines' control by networking distributed information from sensors that are wirelessly powered and interrogated.

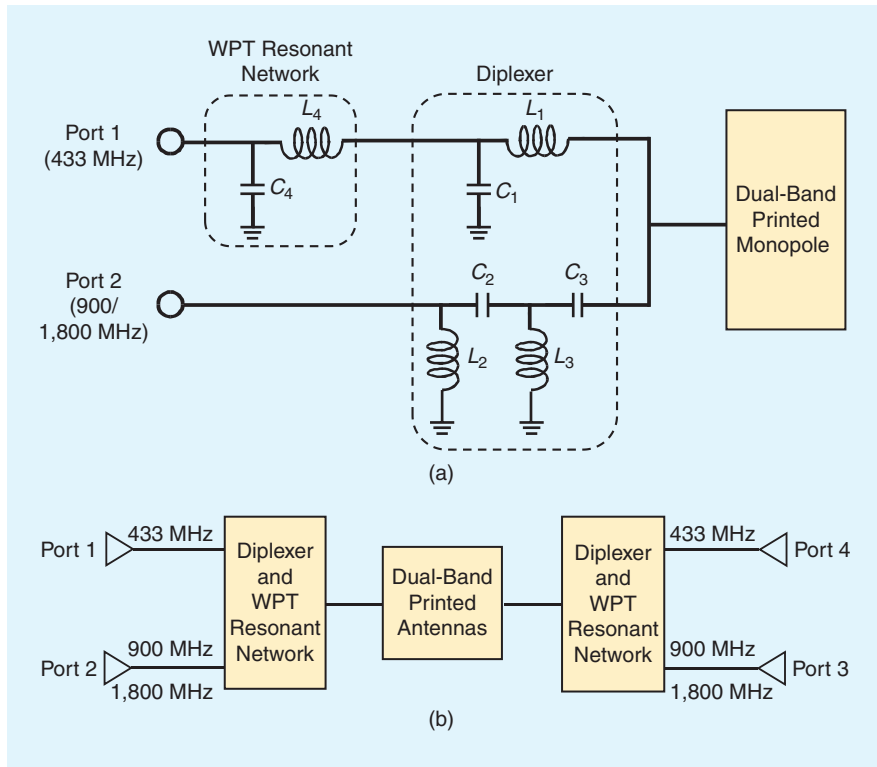

Figure 10. (a) A diplexer topology and (b) the architecture of the system based on the frequency-division mechanism for both power and data transfer [44].

Far-Field Ultralow Power and Data Transfer

Simultaneous communication and power transfer between mobile phones and different kinds of radiating subsystems may also rely on far-field propagation for both wireless operations. Great attention is devoted in the literature to this crucial problem, from both high-level (signal-processing) [47]–[49] and low-level (circuit design) [10], [50] standpoints.

Interesting solutions (not devoted specifically to portable devices but rather to next-generation RFID tags) that could be integrated into portable devices focus on adopting the ultrawide band (UWB) for communication/localization purposes, while performing

energy recovery in the low [51], [52] or high [53] UHF bands. Such UWB technology matches the 5G requirements in terms of extremely low power consumption, while simultaneously providing robustness versus fast fading and thus submeter precision in indoor localization [54].

All the cited works offer colocalization solutions of two separate antennas. In this way, space-consuming architectures are achieved both because of the antenna footprints and because of the two separate antenna ports: one for UWB (typically, backscattered) communication and the other for UHF harvesting. As

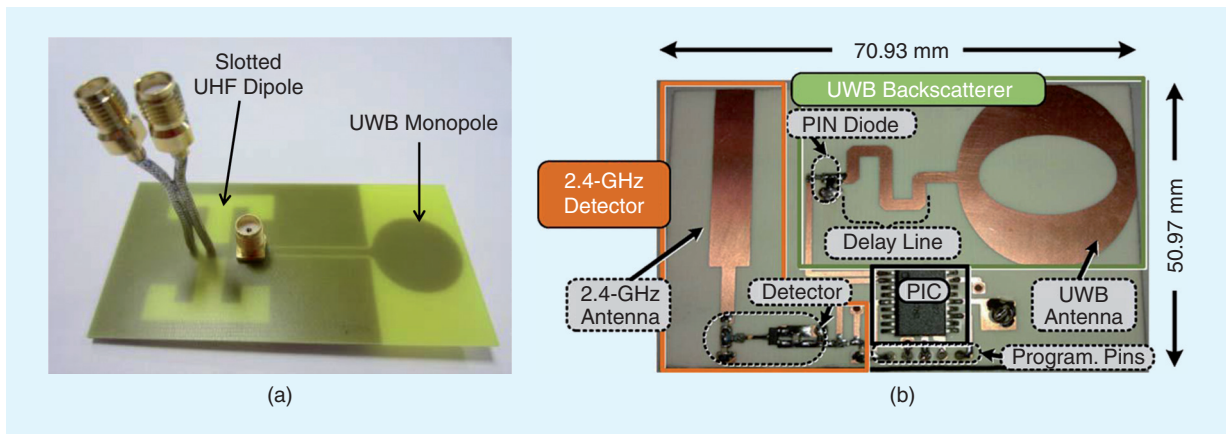

Figure 11. Photos of the prototypes for two colocalized UWB and UHF antennas with separate ports: from (a) [52] and (b) [53]. PIC: photonic integrated circuit. <Au: Is this correct for PIC?>

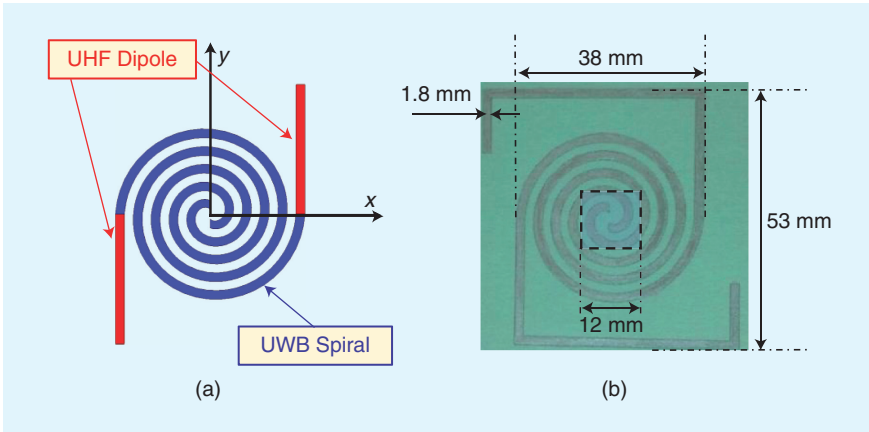

Figure 12. (a) UWB-UHF single-port antenna integration; (b) final prototype on paper substrate (the dashed area indicates the backside diplexer) [55].

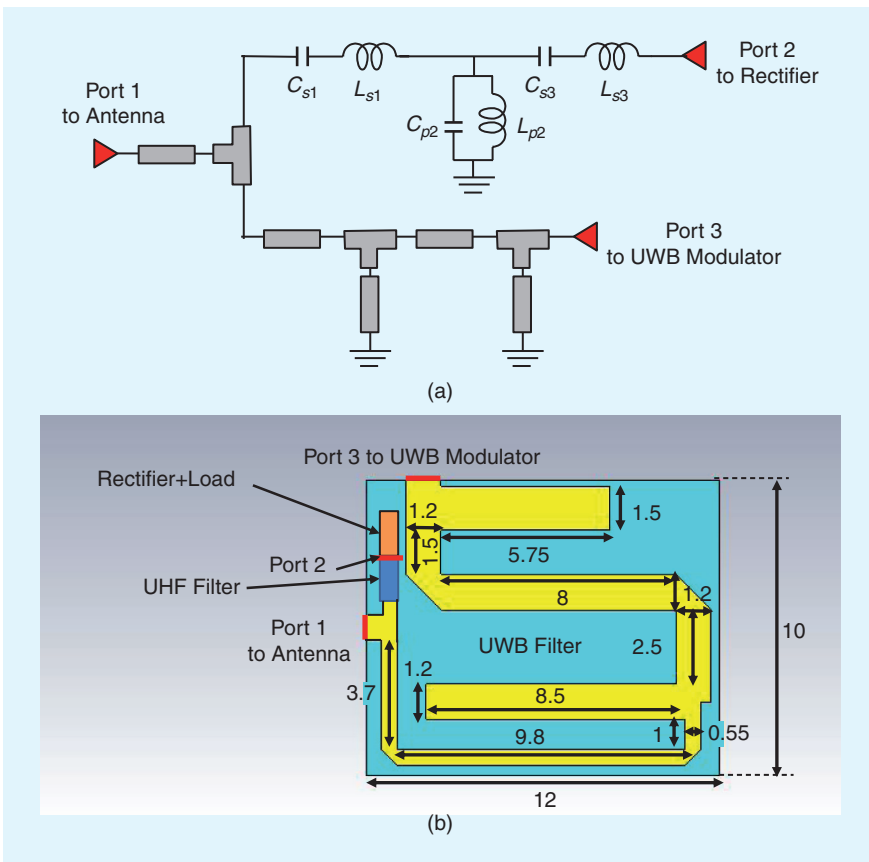

Figure 13. (a) The circuit schematic of the three-port diplexer and (b) the corresponding layout on paper substrate (dimensions in millimeters) [8].

representative examples, Figure 11 shows two quite compact colocated antenna solutions, in which each antenna maintains its own port and related matching network. In Figure 11(a), a slotted UHF dipole (operating at 868 MHz) is obtained from the ground plane of the UWB monopole [52]; in Figure 11(b), the UWB antenna and UHF monopole (operating at 2.4 GHz) share the same substrate layer [53].

A further step forward is provided in [8], [55], where an original radiating subsystem, consisting

of a single-port antenna on paper substrate, is able to both communicate and scavenge energy by resorting to the European low UWB band (3.1–4.8 GHz) and the low UHF band (868 MHz), respectively. For the energy recovery, this application foresees the use of intentional sources operating at 868 MHz (or “RF showers”) to periodically provide the requested amount of energy to the batteryless tags, realized in eco-compatible materials and equipped with rectenna systems. An extremely compact and low-profile antenna layout is depicted in Figure 12: here, a standard Archimedean spiral antenna covers the UWB band, while a planar dipole, resonant at 868 MHz, is obtained by prolonging the spiral arms, as shown in Figure 12(a), and involving all the nested loops of the spiral, thus providing a dipole that is 1.5λ long.

Figure 12(b) shows the paper prototype; here, the reported dashed square area gives the footprint of the three-port diplexing network, the role of which is identical to that of one of the previous examples [see Figure 10(a)]. In this case, the frequency division is obtained by means of a lumped-element and a distributed-element matching/filtering network for the UHF and UWB paths, respectively. The schematic view of the diplexer and its electromagnetically designed

layout are shown in Figure 13(a) and (b), respectively. The simultaneous communication and power transfer are feasible because of both a high decoupling between the two bands and a good matching between the two-mode antenna and the corresponding path. These behaviors are demonstrated in Figure 14, where the reflection coefficient at the antenna port (S11) and the transmission coefficient of the UHF path (S12) are plotted for different loading conditions at the UWB port; in addition, the transmission coefficient of the UWB path

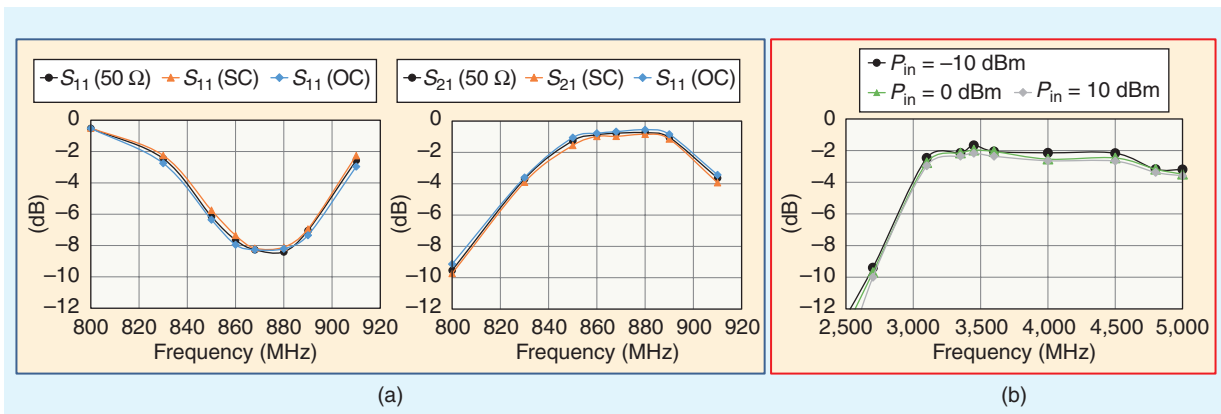

Figure 14. (a) The UHF matching and filtering performance distortion during the UWB modulation. (b) The UWB insertion loss for different incident RF power levels [55]. SC: short circuit; OC: open circuit.

(S13) is plotted for different UHF power levels at the nonlinear rectifier input port <AU: Please check that edit here retains intended meaning>.

Conclusions

In this article, we have provided an overview of several recent solutions for the wireless powering of devices exploiting either near-field or far-field techniques. We first introduced a general system design procedure, as well as its figure of merits and main building block components. A growing number of engineers and researchers have been studying this technology over the last several years, for both intentional power transfer and ambient EH and addressing a variety of stand-alone applications that exploit different physical mechanisms, operating frequencies, and power levels. Because of this widespread interest, increasing efforts are being made to define standard rules for specific purposes, but these have not as yet been unified.

At the same time, this technology has assumed a leading role in realizing the IoT/IoE paradigm within the framework of coming 5G systems: indeed, quite a few proofs of concept are currently available in civil and industrial scenarios that can be integrated into the features of 5G systems. From this perspective, WPC is foreseen as fundamental for the actual implementation of a 5G multilayered architecture. Thus, a new networking paradigm, WPCNs, has been introduced [55] that integrates two paradigms: WPT and wireless communications. This will open the way to a number of future research investigations related to overall system architectures and to developing hardware and software solutions capable of exploiting the energy available and minimizing its consumption, while accounting not only for the impact of user density and their mobility but also for potential regulatory issues.

Indeed, the main challenges for WPCNs will be to conform to the low wireless power available over long distances as well as the complexity involved in jointly

transferring both wireless information and power over the same network. These challenges will open the way to further exploration of the already rich signal processing literature combined with smart beamforming solutions.

Acknowledgement

This work was partly funded by the EU-supported Regional Operative Project HABITAT (Home Assistance Based on Internet of Things for the Autonomy of Everybody) (<http://www.habitatproject.info>) and by the COST action IC1301 WiPE (Wireless Power Transmission for Sustainable Electronics) (<http://www.cost-ic1301.org/>).

References

- [1] L. Roselli, et al. "Smart surfaces: Large area electronics systems for internet of things enabled by energy harvesting," *Proc. IEEE*, vol. 102, no. 11, pp. 1723–1746, Nov. 2014. <AU: Please provide all the author names.>
- [2] M. Magno, V. Jelicic, B. Srbinovski, V. Bilas, E. Popovici, and L. Benini, "Design, implementation, and performance evaluation of a flexible low-latency nanowatt wake-up radio receiver," *IEEE Trans. Ind. Inform.*, vol. 12, no. 2, pp. 633–644, Apr. 2016.
- [3] D. Bandyopadhyay and J. Sen, "Internet of things: Applications and challenges in technology and standardization," *Wireless Pers. Commun.*, vol. 58, no. 1, pp. 49–69, 2011.
- [4] M. R. Palattella, et al. "Internet of things in the 5G Era: Enablers, architecture, and business models," *IEEE J. Sel. Area. Commun.*, vol. 34, no. 3, pp. 510–527, Mar. 2016. <AU: Please provide all the author names.>
- [5] E. Hossain, M. Rasti, H. Tabassum, and A. Abdelnasser, "Evolution toward 5G multi-tier cellular wireless networks: An interference management perspective," *IEEE Wireless Commun.*, vol. 21, no. 3, pp. 118–127, June 2014.
- [6] S. Bi, C. K. Ho, and R. Zhang, "Wireless powered communication: opportunities and challenges," *IEEE Commun. Mag.*, vol. 53, no. 4, pp. 117–125, Apr. 2015.
- [7] N. S. Jeong and F. Carobolante, "Enabling wireless power transfer through a metal encased handheld device," in *Proc. IEEE Wireless Power Transfer Conf.*, Aveiro, 2016, pp. 1–3.
- [8] M. Fantuzzi, D. Masotti, and A. Costanzo, "A novel integrated UWB-UHF one-port antenna for localization and energy harvesting," *IEEE Trans. Antennas. Propagat.*, vol. 63, no. 9, pp. 3839–3848, Sept. 2015.
- [9] C. Edwards, "Smart dust," *Eng.Technol.*, vol. 7, no. 6, pp. 74–77, July 2012.

- [10] M. Del Prete, A. Costanzo, D. Masotti, T. Polonelli, M. Magno, and L. Benini, "Experimental analysis of power optimized waveforms for enhancing wake-up radio sensitivity," in *Proc. IEEE MTT-S Int. Microwave Symp.*, San Francisco, CA, 2016, pp. 1–4.
- [11] A. Costanzo and D. Masotti, "Wirelessly powering: An enabling technology for zero-power sensors, IoT and D2D communication," in *Proc. IEEE MTT-S Int. Microwave Symp.*, Phoenix, AZ, 2015, pp. 1–4.
- [12] National Italian Project PRIN-GRETA. (2012-2015). GREen TAGs and sensors with ultra-wideband identification and localization capabilities [Online]. Available: <http://www.greentags.eu/>
- [13] O. Galinina, H. Tabassum, K. Mikhaylov, S. Andreev, E. Hossain, and Y. Koucheryavy, "On feasibility of 5G-grade dedicated RF charging technology for wireless-powered wearables," *IEEE Wireless Commun.*, vol. 23, no. 2, pp. 28–37, Apr. 2016.
- [14] K. Huang, C. Zhong, and G. Zhu, "Some new research trends in wirelessly powered communications," *IEEE Wireless Commun.*, vol. 23, no. 2, pp. 19–27, Apr. 2016.
- [15] A. Costanzo and D. Masotti, "Smart solutions in smart spaces: Getting the most from far-field wireless power transfer," *IEEE Microwave Mag.*, vol. 17, no. 5, pp. 30–45, May 2016.
- [16] A. Boaventura, D. Belo, R. Fernandes, A. Collado, A. Georgiadis, and N. Borges Carvalho, "Boosting the efficiency: Unconventional waveform design for efficient wireless power transfer," *IEEE Microwave Mag.*, vol. 16, no. 3, pp. 87–96, Apr. 2015.
- [17] Y. Shen, C. Jiang, T. Q. S. Quek, and Y. Ren, "Location-aware device communication design: exploration and exploitation on energy," *IEEE Wireless Commun.*, vol. 23, no. 2, pp. 46–52, Apr. 2016.
- [18] V. Rizzoli, D. Masotti, N. Arbizzani, and A. Costanzo, "CAD procedure for predicting the energy received by wireless scavenging systems in the near- and far-field regions," in *Proc. IEEE MTT-S Int. Microwave Symp. Digest*, Anaheim, CA, 2010, pp. 1768–1771.
- [19] EU-Supported Regional Operative Project HABITAT. (2016-2018). Home assistance based on the internet of things for the autonomy [Online]. Available: <http://www.habitatproject.info/>
- [20] J. L. Gómez-Tornero, M. Poveda-García, R. Guzmán-Quirós, and J. C. Sánchez-Arnaus, "Design of Ku-band wireless power transfer system to empower light drones," in *Proc. IEEE Wireless Power Transfer Conf.*, Aveiro, 2016, pp. 1–4.
- [21] D. Masotti, A. Costanzo, M. Del Prete, and V. Rizzoli, "Time-modulation of linear arrays for real-time reconfigurable wireless power transmission," *IEEE Trans. Microwave Theory Tech.*, vol. 64, no. 2, pp. 331–342, Feb. 2016.
- [22] G. Chattopadhyay, et al., "Millimeter-wave wireless power transfer technology for space applications," in *Proc. Asia-Pacific Microwave Conf.*, Macau, 2008, pp. 1–4. <AU: Please provide all the author names.>
- [23] M. Nariman, F. Shirinfar, A. Papió Toda, S. Pamarti, A. Rofougaran, and F. De Flaviis, "A compact 60-GHz wireless power transfer system," *IEEE Trans. Microwave Theory Tech.*, vol. 64, no. 8, pp. 2664–2677, Aug. 2016.
- [24] S. Mao, J. Zhang, K. Song, G. Wei, and C. Zhu, "Wireless power transfer using a field-enhancing coil and a small-sized receiver with low coupling coefficient," *IET Power Electron.*, vol. 9, no. 7, pp. 1546–1552, Aug. 2016.
- [25] K. F. Warnick, R. B. Gottula, S. Shrestha, and J. Smith, "Optimizing power transfer efficiency and bandwidth for near field communication systems," *IEEE Trans. Antennas. Propagat.*, vol. 61, no. 2, pp. 927–933, Feb. 2013.
- [26] F. Mastri, A. Costanzo, and M. Mongiardo, "Coupling-independent wireless power transfer," *IEEE Microwave Wireless Compon. Lett.*, vol. 26, no. 3, pp. 222–224, Mar. 2016.
- [27] B. W. Flynn and K. Fotopoulou, "Rectifying loose coils: Wireless power transfer in loosely coupled inductive links with lateral and angular misalignment," *IEEE Microwave Mag.*, vol. 14, no. 2, pp. 48–54, Mar./Apr. 2013.
- [28] A. Costanzo, M. Dionigi, D. Masotti, M. Mongiardo, G. Monti, L. Tarricone, and R. Sorrentino, "Electromagnetic energy harvesting and wireless power transmission: A unified approach," *Proc. IEEE*, vol. 102, no. 11, pp. 1692–1711, Nov. 2014.
- [29] A. Pacini, F. Mastri, R. Trevisan, D. Masotti, and A. Costanzo, "Geometry optimization of sliding inductive links for position-independent wireless power transfer," in *Proc. IEEE Int. Microwave Symp.*, San Francisco, CA, 2016, pp. 1–4.
- [30] J. Kim, D. H. Kim, J. Choi, K. H. Kim, and Y. J. Park, "Free-positioning wireless charging system for small electronic devices using a bowl-shaped transmitting coil," *IEEE Trans. Microwave Theory Tech.*, vol. 63, no. 3, pp. 791–800, Mar. 2015.
- [31] S. Yoshida, N. Hasegawa, and S. Kawasaki, "Experimental demonstration of microwave power transmission and wireless communication within a prototype reusable spacecraft," *IEEE Microwave Wireless Compon. Lett.*, vol. 25, no. 8, pp. 556–558, Aug. 2015.
- [32] H. Tonomura, J. Miyakoshi, and N. Shinohara, "Researches of microwave safety issue of wireless power transfer technology for commercial vehicles," in *Proc. 9th European Conf. Antennas and Propagation*, Lisbon, 2015, pp. 1–4.
- [33] A. Yakovlev, S. Kim, and A. Poon, "Implantable biomedical devices: Wireless powering and communication," *IEEE Commun. Mag.*, vol. 50, no. 4, pp. 152–159, Apr. 2012.
- [34] A. S. Y. Poon, S. O'Driscoll, and T. H. Meng, "Optimal frequency for wireless power transmission into dispersive tissue," *IEEE Trans. Antennas. Propagat.*, vol. 58, no. 5, pp. 1739–1750, May 2010.
- [35] Z. Popovic, "Cut the cord: Low-power far-field wireless powering," *IEEE Microwave Mag.*, vol. 14, no. 2, pp. 55–62, Mar./Apr. 2013.
- [36] A. Costanzo, A. Romani, D. Masotti, N. Arbizzani, and V. Rizzoli, "RF/baseband co-design of switching receivers for multiband microwave energy harvesting," *Sens. Actuators A Phys.*, vol. 179, no. 1, pp. 158–168, Mar. 2012.
- [37] H.J. Visser, A.C.F. Reniers, and J.A.C. Theeuwes, "Ambient RF energy scavenging: GSM and WLAN power density measurements," in *Proc. 38th European Microwave Conf.*, Oct. 2008, pp. 721–724.
- [38] M. Pinuela, P. D. Mitcheson, and S. Lucyszyn, "Ambient RF energy harvesting in urban and semi-urban environments," *IEEE Trans. Microwave Theory Tech.*, vol. 61, no. 7, pp. 2715–2726, July 2013.
- [39] A. Costanzo, D. Masotti, A. Romani, and M. Tartagni, "Energy scavenging and storage for RFID systems", chapter in book," in *Green RFID Systems*, L. Roselli, Ed. Cambridge, U.K.: Cambridge Univ. Press, Sept. 2014.
- [40] R. Zhang and C. K. Ho, "MIMO broadcasting for simultaneous wireless information and power transfer," *IEEE Trans. Wireless Commun.*, vol. 12, no. 5, pp. 1989–2001, May 2013.
- [41] R. Trevisan and A. Costanzo, "A UHF near-field link for passive sensing in industrial wireless power transfer systems," *IEEE Trans. Microwave Theory Tech.*, vol. 64, no. 5, pp. 1634–1643, May 2016.
- [42] J. Wu, C. Zhao, Z. Lin, J. Du, Y. Hu, and X. He, "Wireless power and data transfer via a common inductive link using frequency division multiplexing," *IEEE Trans. Ind. Electron.*, vol. 62, no. 12, pp. 7810–7820, Dec. 2015.
- [43] S. Radiom, M. Baghaei-Nejad, K. Aghdam, G. A. E. Vandenbosch, L. R. Zheng, and G. E. Gielen, "Far-field on-chip antennas monolithically integrated in a wireless-powered 5.8-GHz downlink/UWB Uplink RFID Tag in 0.18- μm standard CMOS," *IEEE J. Solid-State Circuits.*, vol. 45, no. 9, pp. 1746–1758, Sept. 2010.
- [44] M. Del Prete, F. Berra, A. Costanzo and D. Masotti, "Exploitation of a dual-band cell phone antenna for near-field WPT," in *Proc. IEEE Wireless Power Transfer Conf.*, Boulder, CO, 2015, pp. 1–4.
- [45] M. Del Prete, F. Berra, A. Costanzo, and D. Masotti, "Seamless exploitation of cell-phone antennas for near-field wpt by a frequency-diplexing approach," *IET Microwave Antenna Propagat.*, pp. 1–16, Nov. 2016. [AU: Please provide the volume number.]
- [46] B. Clerckx and E. Bayguzina, "Waveform design for wireless power transfer," *IEEE Trans. Sig. Process.*, vol. 64, no. 23, pp. 6313–6328, Dec. 2016.
- [47] Y. Liu, L. Wang, S. A. Raza Zaidi, M. El-kashlan, and T. Q. Duong, "Secure D2D communication in large-scale cognitive cellular networks: A wireless power transfer model," *IEEE Trans. Commun.*, vol. 64, no. 1, pp. 329–342, Jan. 2016.
- [48] D. Zhang, Z. Zhou, S. Mumtaz, J. Rodrigues, and T. Sato, "One integrated energy efficiency proposal for 5G IoT communications,"

IEEE Internet Things J., no. 99, pp. 1–1. <AU: Please provide the volume number and the year.>

- [49] X. Zhou, R. Zhang, and C. K. Ho, "Wireless information and power transfer: Architecture design and rate-energy tradeoff," *IEEE Trans. Commun.*, vol. 61, no. 11, pp. 4754–4767, Nov. 2013.
- [50] A. S. Boaventura and N. B. Carvalho, "Evaluation of simultaneous wireless power transfer and backscattering data communication through multisine signals," in *Proc. IEEE Wireless Power Transfer Conf.*, Boulder, CO, 2015, pp. 1–3.
- [51] C. C. Cruz, J. R. Costa, and C. A. Fernandes, "Hybrid UHF/UWB antenna for passive indoor identification and localization systems," *IEEE Trans. Antennas Propagat.*, vol. 61, no. 1, pp. 354–361, Jan. 2013.
- [52] M. Pigeon, R. D'Errico, and C. Delaveaud, "'UHF-UWB tag antenna for passive RFID applications," in *Proc. 7th European Conf. Antennas and Propagation*, 2013, pp. 3968–3972.
- [53] A. Ramos, A. Lazaro, and D. Girbau, "Semi-passive time-domain UWB RFID system," *IEEE Trans. Microwave Theory Tech.*, vol. 61, no. 4, pp. 1700–1708, Apr. 2013.
- [54] D. Dardari, R. D'Errico, C. Roblin, A. Sibille, and M. Win, "Ultra-wide bandwidth RFID: The next generation?" *Proc. IEEE*, vol. 98, no. 9, pp. 1570–1582, Aug. 2010.
- [55] M. Fantuzzi, D. Masotti, and A. Costanzo, "Simultaneous UHF energy harvesting and UWB-RFID communication," in *Proc. IEEE MTT-S Int. Microwave Symp.*, May 2015, pp. 1–4.
- [56] D. Niyato, D. I. Kim, Z. Han, and M. Maso, "Wireless powered communication networks: architectures, protocol designs, and standardization," *IEEE Wireless Commun.*, vol. 23, no. 2, pp. 8–9, 2016.

Callouts:

With the scenario of a 5G IoT in mind, many researchers are currently focused on the challenging task of recharging ubiquitous devices and machines wirelessly to allow truly perpetual wireless-powered communication.

Simultaneous wireless information and power transfer (SWIPT) is currently being investigated in a wide range of different systems for both civil and industrial applications.

The challenges for 5G cellular wireless networks lie mainly in improving overall system behavior in terms of end-to-end performance, energy consumption, and cost per information transfer.

When dealing with simultaneous data and power transmission, the frequency-division approach is often adopted.

Recent studies have also demonstrated the possibility of reusing existing portable device antennas, designed for multiband far-field communication, in a loosely coupled near-field link.

Simultaneous communication and power transfer between mobile phones and different kinds of radiating subsystems may also rely on far-field propagation for both wireless operations.